

**KONDO**<sup>®</sup>

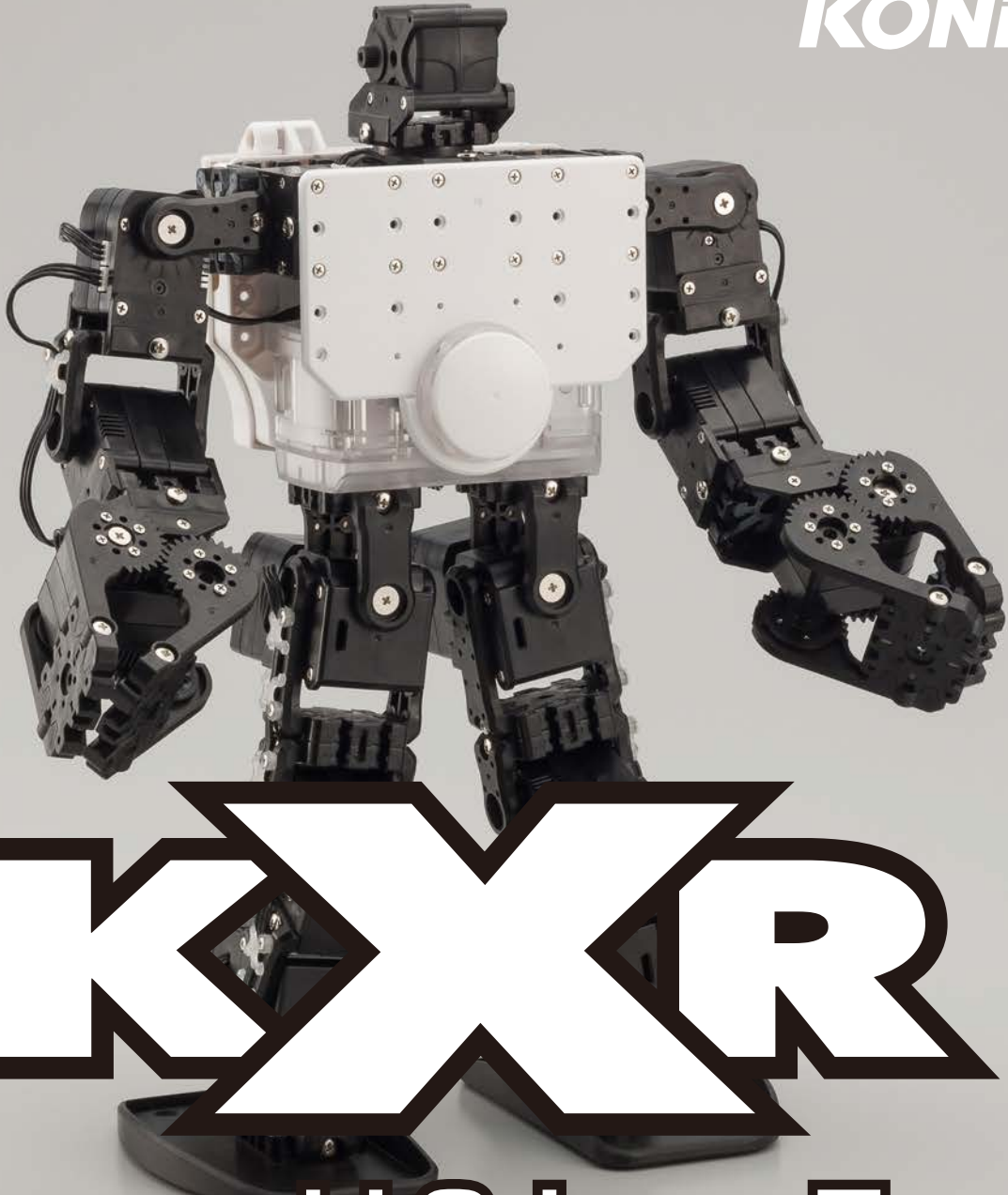

# KXR

**Humanoid Gripper Type**

**KXR-L2G**

**Assembly  
Manual**

**Support Information**

*[www.kondo-robot.com](http://www.kondo-robot.com)*

**KONDO KAGAKU Co., Ltd.**

Service Dept.

[support@kondo-robot.com](mailto:support@kondo-robot.com)

# Table of Contents

■ Safety Precautions	3
■ Preface	4
■ Prior to Assembly	5
● List of Parts Used	5
● Accessories	9
● Servo Motors	11
● Screw Handling	12
● Frame Parts	13
● Servo ID and Position	15
■ Robot Assembly	16
● Full Robot Assembly Procedures	16
● Servo ID Setting	17
● Body Assembly	20
● Gripper Assembly	33
● Arm Assembly	33
● Right Leg Assembly	44
● Left Leg Assembly	50
● Combination Parts	58
■ Robot Operations	69
● Battery Mounting	69
● Connecting with PC	70
● Trim Confirmation	73
● Running Sample Motions	80
● Reduced Voltage Motion Settings	86
■ Options	87
● Option Parts List	87
● Option Mounting Examples	89

# Safety Precautions

Due to the nature of this product as an assembly kit, consequences, damage, or injury resulting from the use of this product are the user's responsibility. Please use this product with that in mind. In order to prevent danger to the user and others, as well as property damages, the safety precautions listed below must be followed.



**DANGER** This sign indicates that "there is imminent danger of death or severe injury."



Prohibited

**Work with sufficient space in a physically and emotionally alert and observant state.**  
There is danger of death or serious injury by unexpected accidents.



**WARNING** This sign indicates that "there is a possibility of death or severe injury."

**Keep all parts away from small children.** Small parts can cause injury.

**Do not break the charger and cable.**

Do not damage, modify, bring in close contact with thermal appliances, or use under forced pressure. Continuous use under such conditions can result in fire or electric shock. \*For repair of cords and cables, please contact our service section. \*If the product becomes wet, please consult our service section.



Prohibited

**Do not disassemble or modify the servo or board of the finished product.**

Disassembly and repair, other than those stated in this Instruction, is prohibited. Incorrect disassembly or assembly can cause malfunctions, fire and/or electric shock. \*In case of any malfunction, please contact our service section.

**Do not allow the product to become wet or use under high humidity and conditions where dew condensation occurs.**

Such conditions may result in malfunction since this product is composed of electronic parts. Such conditions can also result in electric shock and fire by electrical shorting.

**Disconnect the battery connector immediately if any thing abnormal occurs.**

\*Damage in the robots body. \*Foreign objects in the robots body. \*Smoke. \*Odd smell. \*Abnormal heat or warmth. Continued use under such conditions can result in fire or electric shock. \*Should any abnormalities be observed, immediately stop using the product and contact our service section.

**Disconnect the power plug from electrical outlets when the charger is not being used.**

When plugged to an outlet, a small amount of electricity flows into.



Mandatory

**During operation, always exercise caution and be prepared for unforeseen accidents.**

Please always remember that due to the nature of this product as an assembly kit, safety is not guaranteed for the movements resulting from the operation of the product. Please take extra precautions since an injury of the fingertips and fracture of bones may result when movements of the product greatly differ from what you expect.

**Recognize the possibility that components can short circuit.**

Short circuit can easily occur since control board terminals are bare. Short circuits can cause the battery, components, and wiring materials to ignite. Incorrect wiring can also result in similar danger.



**CAUTION** This sign indicates that "there is a possibility of injury or material damage".



Prohibited

**Do not operate on an unstable work surface.**

The product can lose balance and collapse or fall off causing injury.

**For overseas use, local approval or license may be needed. Please check.**

In certain areas or countries, legal procedures may be necessary prior to using the product. \*Our support does not apply to the use of this product outside of Japan.



Mandatory

**When detaching the charger and battery, firmly hold the connectors.**

Detachment by holding the cord may cause breaking of wires and a possible short circuit, which can result in electric shock or fire.



**The battery included with this product is a nickel-metal hydride battery. To protect valuable environmental resources, used batteries should be recycled, not disposed of as trash.**

# Preface

Thank you for purchasing the KXR robot assembly kit.

The KXR system enables you to create various robots by combining frame parts with servo motors as a part of the structure. The basic format is provided as a set, and sample motions are also included, so you can confirm the robot's operations as soon as it is assembled. Servos and main frame part components are sold as options, so it is easy to add robots in various formats and also expand the original robot. If parts wear out or break you can replace only those you need, so repairs can also be performed inexpensively.

Before beginning to assemble the robot, please closely read through this manual and the accessory manuals. You may want to print out the manuals to make them easier to read and reference.

## Caution

1

Please keep in mind that due to the nature of this product as an assembly kit, the motion of the assembled product cannot be guaranteed. Further, due to the fact that the movements of the assembled product depend in large part on the method by which it was assembled, we may not be able to provide precise answers to your questions regarding operations.

2

This product is constructed for people of all ages to enjoy a bipedal robot. However, this product is not a toy, and contains parts and tasks that would be difficult for young children to understand or perform. For those parts and tasks, parents or teachers should provide assistance.

3

The assembly and operation of this product requires the use of a personal computer (Windows Vista or 7,8,8.1,10) with a USB port. It is assumed that the user has basic computer skills. Please note that we cannot provide answers to general questions or inquiries regarding computers or Windows.

- All company names, trade names, and logo marks that appear in this Instruction are trade marks or registered trade marks of each respective company.
- The contents of this Instruction and product are subject to change without notice for improvement or other reasons.

## Preparation

The following items are required for the assembly and operation of this product:

### ● Personal computer

OS: Windows Vista, 7, 8, 8.1, 10  
CD-ROM drive (for installation) 1 or more USB 2.0 port(s)  
※ Microsoft .NET Framework 2.0 is required

### ● Tools

- #0 and #1 screwdriver

#0

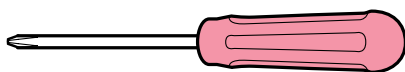

#1

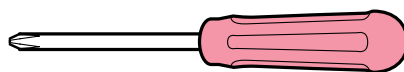

- Small blade

- Nippers

for cutting parts and board cover

- Tape

- Screw locking adhesive

(moderate strength)  
convenient for preventing screws and nuts from loosening.



## ■ Servo

### First, Setting Servo IDs.

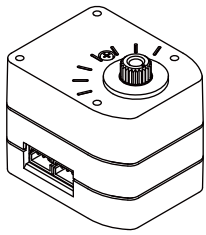

No. 03115  
No. 03116 (6pcs)  
KRS-3301 ICS

**12 x**



No. 03103  
No. 03104 (6pcs)  
No. 03105 (18pcs)  
KRS-3304 ICS

**6 x**



Example of ID sticker application

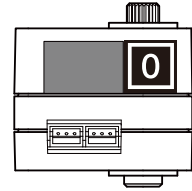

## ■ Frame Parts

**A**



No. 02300  
Joint Base

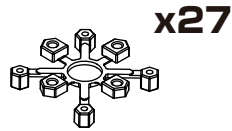

No. 02301  
Joint Nut



No. 02314  
Cable Guide X

**B**

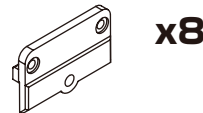

No. 02305  
Joint Frame  
3300A

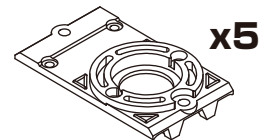

No. 02306  
Arm supporter  
3300A

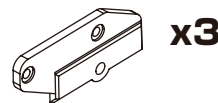

No. 02305  
Joint Frame  
3300B-a

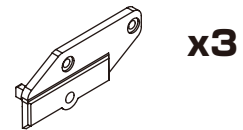

No. 02305  
Joint Frame  
3300B-b

**C**

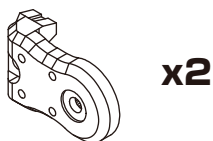

No. 02304  
Upper Arm 3300-20

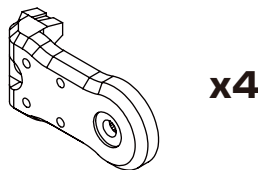

No. 02303  
Upper Arm 3300-26

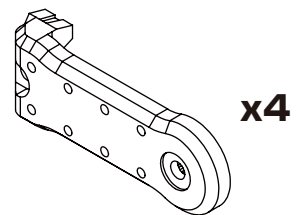

No. 02302  
Upper Arm 3300-38

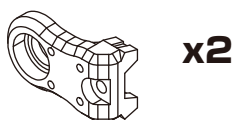

No. 02304  
Bottom Arm 3300-20

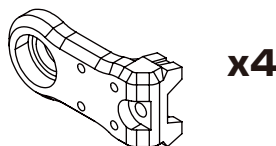

No. 02303  
Bottom Arm 3300-26

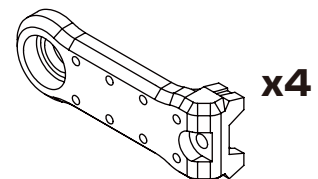

No. 02302  
Bottom Arm 3300-38

\*No. xxxxx is the option part number. Use this number for searches and inquiries.



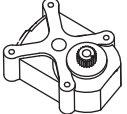
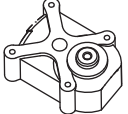
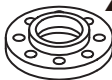
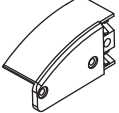
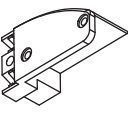

\*There may be more parts included in the set than the number used.

### ■ Frame Parts

**D**

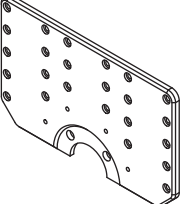
 <b>x5</b>	 <b>x2</b>	 <b>x2</b>
No. 02157 Small Diameter Horn B	No. 02309 Dummy Servo -Upper	No. 02309 Dummy Servo -Bottom
 <b>x6</b>	 <b>x2</b>	 <b>x2</b>
No. 02159 Small Diameter Horn C	No. 02308 Angle Bracket-a	No. 02308 Angle Bracket-b

**E**

 <b>x2</b>	 <b>x1</b>
No. 02311 Body Panel	No. 02311 Lock Ring Cap
 <b>x2</b>	 <b>x1</b>
No. 02311 Panel Spacer	No. 02313 Lock Ring

**F**

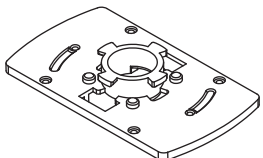
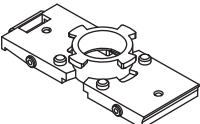
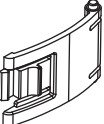
 <b>x2</b>	
No. 02313 BT Box Plate	
 <b>x2</b>	 <b>x2</b>
No. 02313 BT Side Plate	No. 02313 BT Hatch

**G**

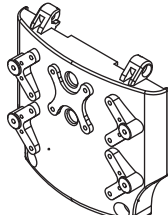
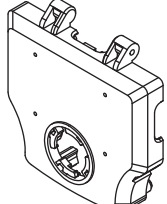
 <b>x1</b>	 <b>x1</b>
No. 02312 Back Pack Cover	No. 02312 Back Pack Base

**H**

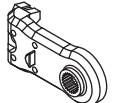
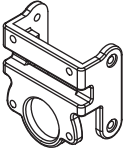
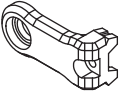
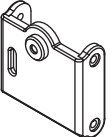
 <b>x4</b>	 <b>4x</b>
No. 02307 Cross Upper Arm-28	No. 02307 Cross Upper Frame
 <b>x4</b>	 <b>x4</b>
No. 02307 Cross Bottom Arm-28	No. 02307 Cross Bottom Frame

**I**

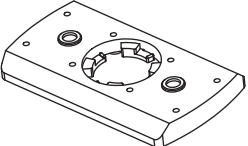
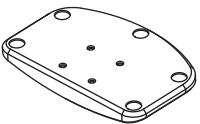
 <b>x1</b>	 <b>x2</b>
No. 02313 BT Leg Plate	No. 02310 Sole S-03

\*No. xxxxx is the option part number. Use this number for searches and inquiries.

\*There may be more parts included in the set than the number used.

### ■Frame Parts

**J**

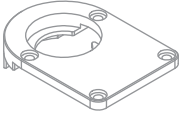

No.02315  
Arm supporter  
3300B

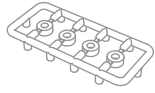

No.02315  
Supporter B  
Spacer

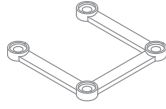

No.02315  
Supporter B  
Spacer 2

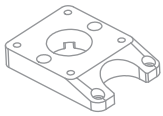

No.02316  
Bottom Spacer  
3300

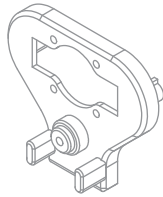

No.02317  
Sensor Base A  
(for Option)

**K**



**x4**

No. 02318  
Gripper A-a

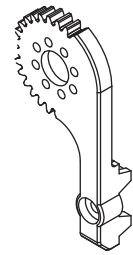

**x4**

No. 02318  
Gripper A-b

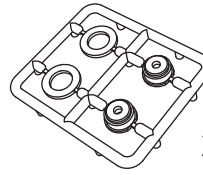

**x2**

No. 02318  
Gripper A  
Spacer/Bush

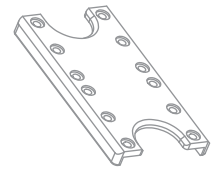

No. 02319  
Flat Frame

**L**

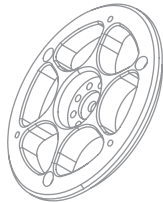

No.02320  
Wheel 60

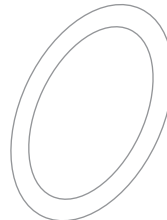

No.02320  
Tire 60











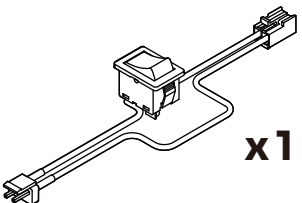

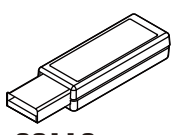
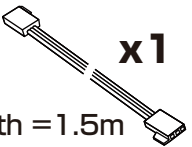
No.02320  
Wheel Spacer

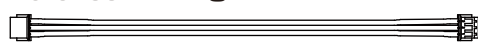
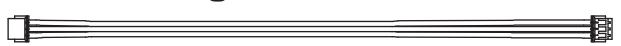
\*No. xxxxx is the option part number. Use this number for searches and inquiries.

\*There may be more parts included in the set than the number used.

## ■ Cable / Screw \*The number of parts used is the maximum number used for each assembly example.

 <p><b>x1</b> No. 02166 LV Power Source Switch Harness</p>	<p><b>x1</b> Length = 100mm</p>  <p>No. 02177 ZH Conversion Cable</p>	<p>No. 02329 Length = 60mm <b>x6</b></p> 
<p>No. 02116 Dual USB Adapter HS</p>  <p><b>x1</b></p>	<p>Length = 1.5m</p>  <p><b>x1</b> Serial Extension Cable</p>	<p>No. 02330 Length = 120mm <b>x5</b></p> 
		<p>No. 02331 Length = 160mm <b>x3</b></p> 
		<p>No. 02332 Length = 200mm <b>x4</b></p> 
<p>ZH Connection Cable 2 A type</p>		

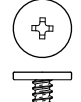
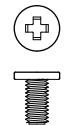
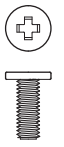
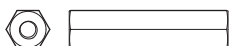
⊕ #0				⊕ #1			
<b>x44</b>	<b>x98</b>	<b>x56</b>		<b>x62</b>	<b>x22</b>	<b>x16</b>	<b>x3</b>
No. 02086	No. 02325	No. 02326	No. 02327	No. 02324	No. 02164	No. 02176	No. 02083
<b>M2 - 4</b>	<b>M2 - 6</b>	<b>M2 - 8</b>	<b>M2 - 12</b>	<b>M2.6 - 10</b>	<b>2.6 - 4</b>	<b>M3 - 6</b>	<b>M3 - 8</b>
Low Head Screw	Low Head Screw	Low Head Screw	Low Head Screw	BH Screw (Bind Head)	Flat Head Screw	Low Head Horn Screw	Low Head Horn Screw
							
<p>No. 02308 <b>M2.6 - 21</b> <b>x2</b></p> <p>Long Nut</p> 							

## ■ Board / Battery / Charger

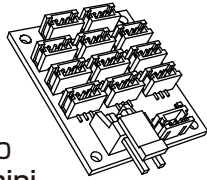
 <p><b>x1</b> No.03120 RCB-4mini</p>	<p><b>x1</b></p> <p>● Battery Ni-MH or Li-Fe</p>	<p><b>x1</b></p> <p>● USB Charger for Ni-MH or Li-Fe</p>
---	--	--

## ■ Accessories

- Kit Guidance
- CD-ROM
- Decal (for KXR) No. 02334

\*No. xxxxx is the option part number. Use this number for searches and inquiries.

\*There may be more parts included in the set than the number used.

## KRS-3300 Series Servo

Servo motors are integrated with gears for raising the output torque and a control board that enables stopping at any angle. Using servo motors in the robot's joints makes it easy to send angle commands to the joints and enables multiple motors to be accurately controlled at the same time. The KRS-3301 ICS servo used in this kit employs half-duplex serial communication, so operating commands can be sent simultaneously to multiple servos, and this allows cables to be wired using the multi-drop/daisy-chain method (method for connecting servos like a chain of beads). This reduces the number of cables connected to the control board to make possible a simpler, cleaner layout. You can also easily upgrade to the higher-grade KRS-3304 ICS for more powerful operating performance.

**Main Features** \*For details, refer to the KRS Servo manual.

- Servo characteristics settings can be changed using the ICS manager
- Supports high-speed communications up to 1.25 Mbps
- As a dedicated robot servo, can be mounted using dual axial support
- Compact cubic design
- The higher-grade model is the same shape, so you can easily upgrade for more power

• Spec

- Size: 32.5 x 26 x 26 (mm)
- Maximum operating angle: 270°
- Proper Voltage: DC 6.0–7.4V

### KRS-3301 ICS

- Weight: 26.4g
- Torque: 6.0kg-cm (7.4V)
- Speed: 0.14s/60° (7.4V)
- Communication standards: ICS3.6
- Gear material: Plastic



### KRS-3304 ICS

- Weight: 33.7g
- Torque: 13.9kg-cm (7.4V)
- Speed: 0.13s/60° (7.4V)
- Communication standards: ICS3.5
- Gear material: Metal



\*For part names, refer to the following page.

## RCB-4mini Control Board

The RCB-4mini control board used in this kit has a total of six ports, three SIO (serial) ports for each of two systems of ICS3.0/3.5/3.6 compliant devices, and can connect up to 36 ICS3.0/3.5/3.6 devices. There are also five AD (analog) ports, so gyro/acceleration and other analog sensors can be used. High-speed, high-capacity EEPROM has been adopted to make it possible to run multiple, varied motions."

• Spec

- Size: 35 x 30 x 12 (mm)
- Weight: 7.6 g
- Interface: SIO port x6  
AD port x5  
COM port x1  
(ZH Connector)
- Proper Voltage: DC 6.0–12.0V

\*Computer software is used to operate the robot's motions.



\*For details, refer to the "Heart to Heart4 User's Manual."

## Battery / Charger

\*The included battery and charger differ with the set.



**Do not use the included USB charger (BX-31LF/BX-32MH) from the USB port of a computer. When charging use a commercially available AC adaptor (1-2A) that supports USB.**

**Make sure to charge the battery before assembly and before operation.  
Read the below content before using the battery.**

### 1. Do not reverse connect/short the battery.

Shorting the terminals causes damage to the battery, which in the worst case may result in the battery emitting smoke or fire. Hold the terminals firmly when disconnecting the battery. Do not pull on the cables. Never try to modify the genuine connectors. Continued use may result in the frame or parts becoming scratched, and the outer insulation of wires may become split. Check the wires periodically to ensure a short circuit does not occur.

### 2. Do not damage the battery. Do not drop or subject to strong impact. Do not disassemble or modify.

If the interior of the battery is exposed, gas may leak and ignite. When using the battery, be sure to check that the outer covering is undamaged, that the battery is fitted securely in the robot body, and that it cannot be damaged by impact due to falling, etc. before turning the switch on. If the battery appears damaged due to impact or if it appears unusual in any way, do not use or recharge it.

### 3. Do not use if the wire insulation is split.

Repeated use may result in the wire insulation becoming damaged and split. Pulling wires across the frame burring or allowing the battery to fall, etc. with the wires exposed may cause damage to the wires. Check the wires periodically, as wires exposed through small gaps in the insulation may result in shorting.

### 4. Do not carry around or store uncovered.

Carrying the battery around in a bag, etc. uncovered may result in metallic objects coming into contact with the battery causing a short out or damaging the battery resulting in a short out. Furthermore, storing in the wrong locations may result in items falling on the battery or water being splashed on the battery resulting in a short out. Always place inside an Li-Fe safety bag when carrying or storing the battery.

### 5. Use the correct type of charger, and make sure all setting values are correct. Be careful not to overcharge the battery.

There are various types of chargers available at a wide variety of prices, and such chargers are designed to charge specific types of batteries. Be sure to use an Li-Fe compatible charger that can provide balanced charging. Furthermore, the capacity of batteries differs. Be sure to set the charger to the rated voltage of the battery and the charge current below the capacity of the battery. Repeatedly charging the battery to unnecessarily high settings may cause damage to the battery or fire. Be extremely careful when charging batteries and do not leave the battery by itself during charging.

### 6. Do not use/store in high temperature/humidity.

Do not use or store in a location that is subject to direct sunlight, or in a location that may become hot such as inside a car or near a heater. Do not use or recharge in locations where it may be splashed with water or where there is a lot of humidity.

### ● Remove the battery from the robot when not in use.

If you store or transport the robot with the battery connected and the switch is accidentally turned on, the servos may be damaged and smoke or fire may result. Always remove the battery when the robot is not in use.

### ▼The following cautions apply when using an Li-Fe battery.

#### ● Do not use at low voltage. Be careful of over discharging.

When batteries are used for a long period of the time, the capacity may reduce and voltage may drop. The same occurs with Li-Fe. **Using a 6.6v rated battery at lower than 6.0v (\*) may damage the battery causing it to swell.** This is known as over discharging. Continued use in this state may result in fire.

\*3.0v for 1 cell.

#### ● Do not use if the battery is swollen.

Swelling is a sign that the battery must not be used any longer. Dispose of the battery in accordance with the laws and rules in your region.

**\*Always refer to the battery and charger manuals before use.**



## Part Name of Servo Motor (KRS-3300 Series)

### Upper Side

Upper Case

Middle Case

Bottom Case

ZH connector

Whichever it is connected to,  
there is no impact on operations.

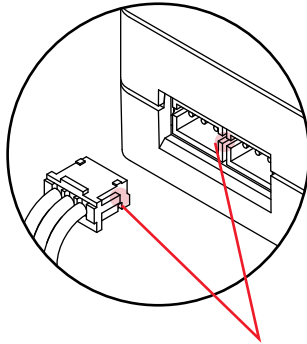

Align the protruding position and firmly insert all the way in.  
Be careful not to push it in backward.

Frame part installation hole

This kit uses M2 screws.

Upper Axis (Final Axis)

**Serration**



Groove surrounding the shaft.

**Origin**

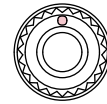

The top of the shaft has a concave  
"origin;" find this position and install  
the part.

**M3 Screw Hole**



This kit uses M3 screws.

### Bottom Side

Bottom Axis (Free Axis)

**2.6 Tapping Screw Hole**

This kit uses 2.6 - 4 screws.

**LED**

The light comes on  
when the power is on.  
KRS-3301 ICS : Red  
KRS-3304 ICS : Blue

Case Screw

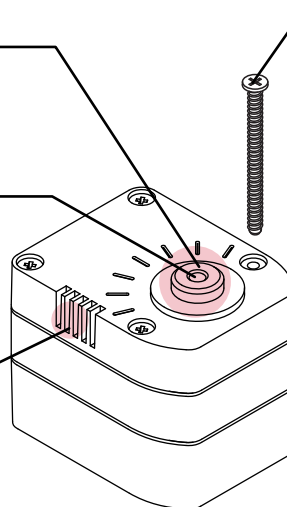

Frame parts are labeled "Upper Side" and "Bottom Side" to indicate  
the installation direction.

### Always use a screwdriver that is right for the screw head.

With this kit, use a #0 screwdriver for M2 screws and #1 screwdriver for M2.6 and larger screws.

"M" refers to millimeter-scale screw thread. Matching metal nuts can be used.

#### Tightening screws

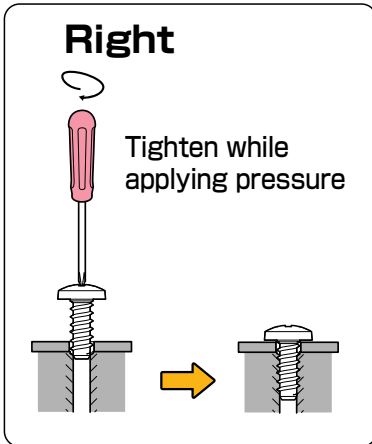

Tighten the screw in a vertical position while applying pressure on the screw head with the screwdriver.

#### With multiple screws

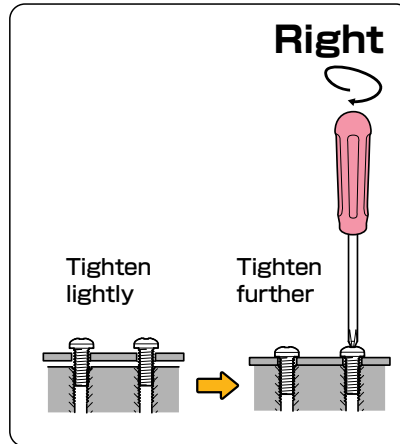

When using several screws to secure parts, first tighten each screw lightly, and then tighten them further to secure the parts evenly with equal force.

#### Tighten screws that are diagonally aligned

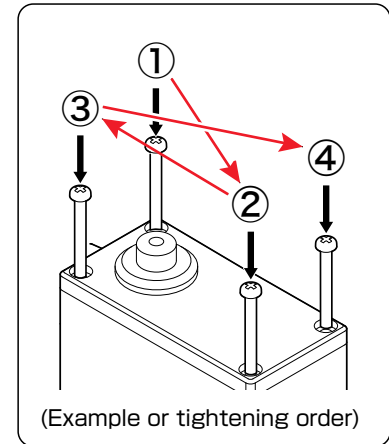

Further, when using more than four screws to secure parts avoid adding uneven pressure to the parts by alternately tightening screws that are diagonally aligned.

If you strip the screw head, remove the screw without applying too much force and then use a new screw.

\*Do not use damaged screws.

If the screw becomes hard to tighten, unscrew it a few revolutions and then tighten again carefully."

#### ■ Removing and re-tightening

##### ① Put the screw in vertically

Lightly turn the screw backward before tightening it and check that it goes into the screw hole cleanly.

##### ② Tighten without applying pressure

Fit the screw in the screw hole and tighten while making sure the screw turns easily.

\*If you tighten the screw while applying too much pressure, the screw hole could break and prevent the screw from binding properly.

Also, be aware that if the screw becomes hard to turn before it's all the way in, it may be going in at an angle.

### Joint Base

Joint parts for connecting the arms and frame, etc. with the servos.

**Put on the plastic joint nut and screw to secure.**

Plastic joint nuts can be replaced with M2/M2.6 metal nuts.

Front Side(Horn Side)

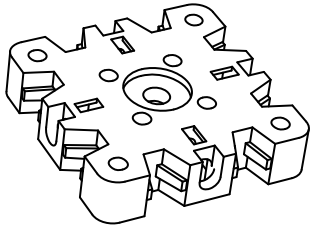

Back Side(Nuts Side)

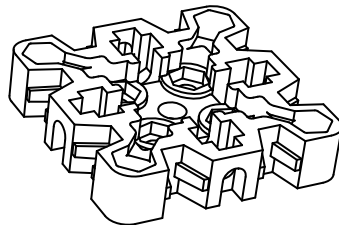

Make sure the installation direction is correct.

#### How to set Joint Nuts

① Bend the M2.6 end.

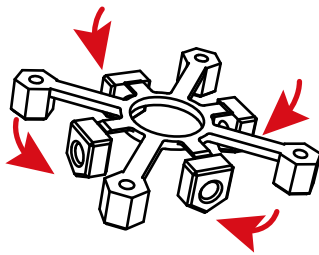

② Fit into the joint base.

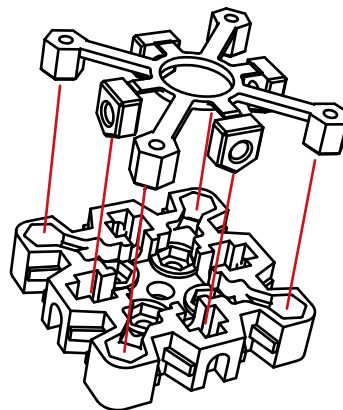

Joint nut screw hole

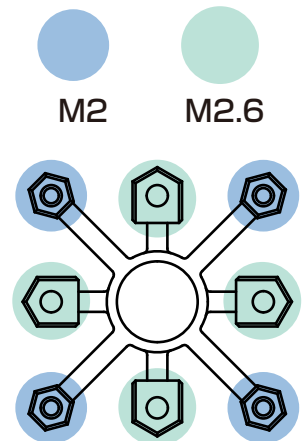

#### Double Joint Base (When installing joint bases)

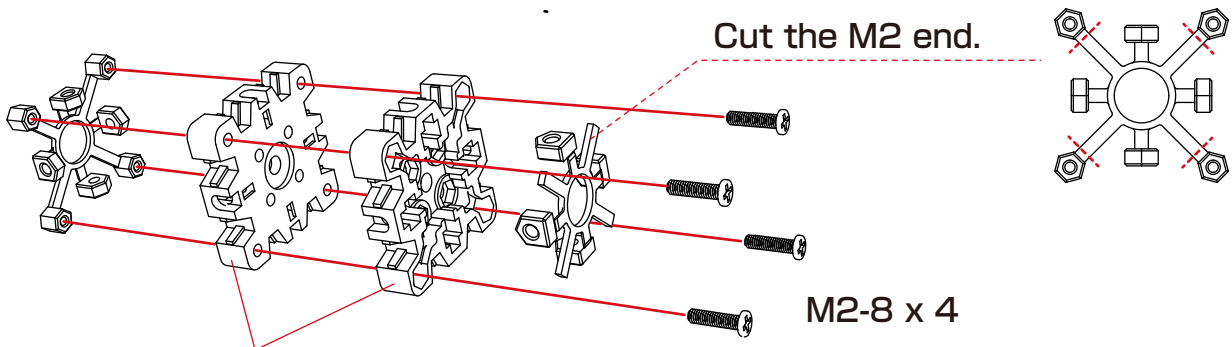

Put the top sides together facing each other.  
(The nut side faces out)

### ■ Arm

This part supports and rotates the servo with two shafts. The upper shaft and bottom shaft are used as a pair. Make sure the position of installation bearings and the length of the arms are correct.

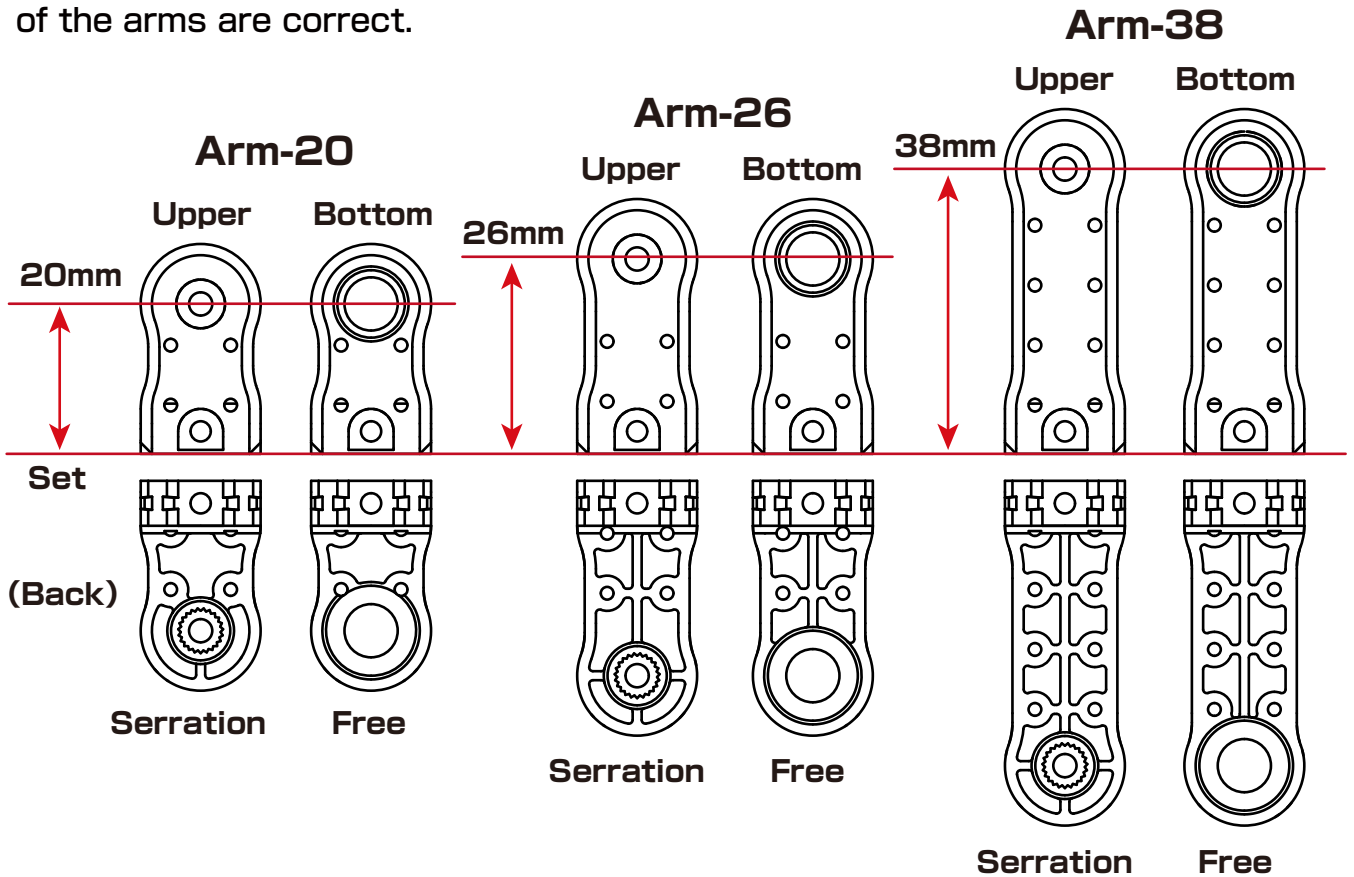

**Caution: Cross upper arm-28 is exclusively with the cross upper frame.**

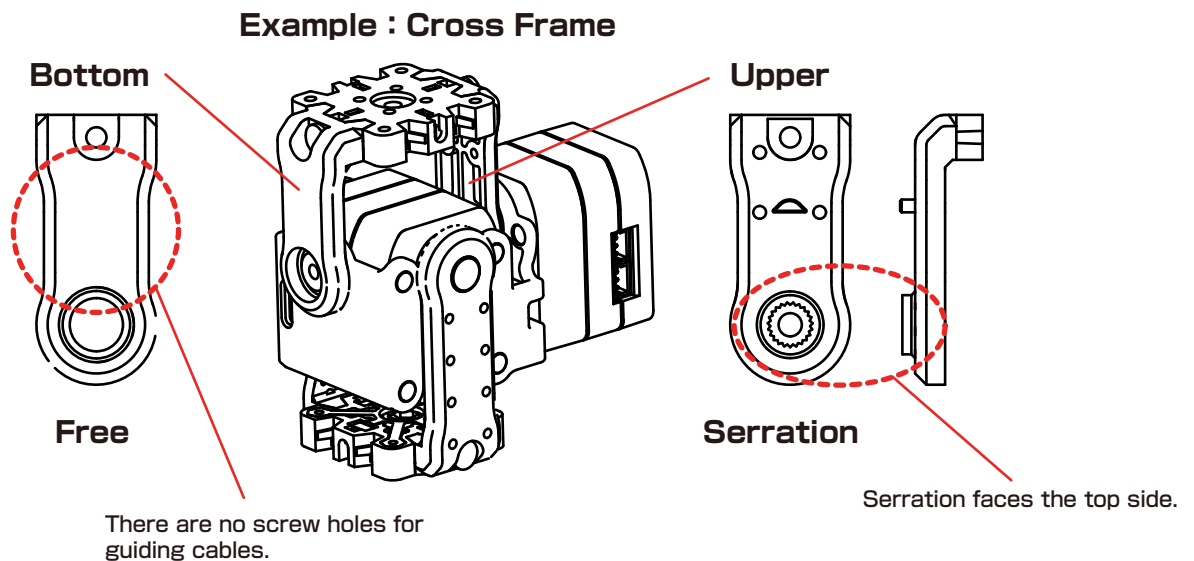

Connect servo to servo and servo to RCB-4mini using ZH-ZH connection cable. RCB-4mini's SIO ports (servo connectors) are divided into two systems, SIO1-3 and SIO5-7. Within the same system, changing the port does not impact operations, but be aware that if the system is incorrect, the robot won't function properly. Servo ID stickers are classified with the symbols ○ and □. \*Always connect ID 0 to the SIO5-7 system.

The explanations in this manual use the following wiring layout.

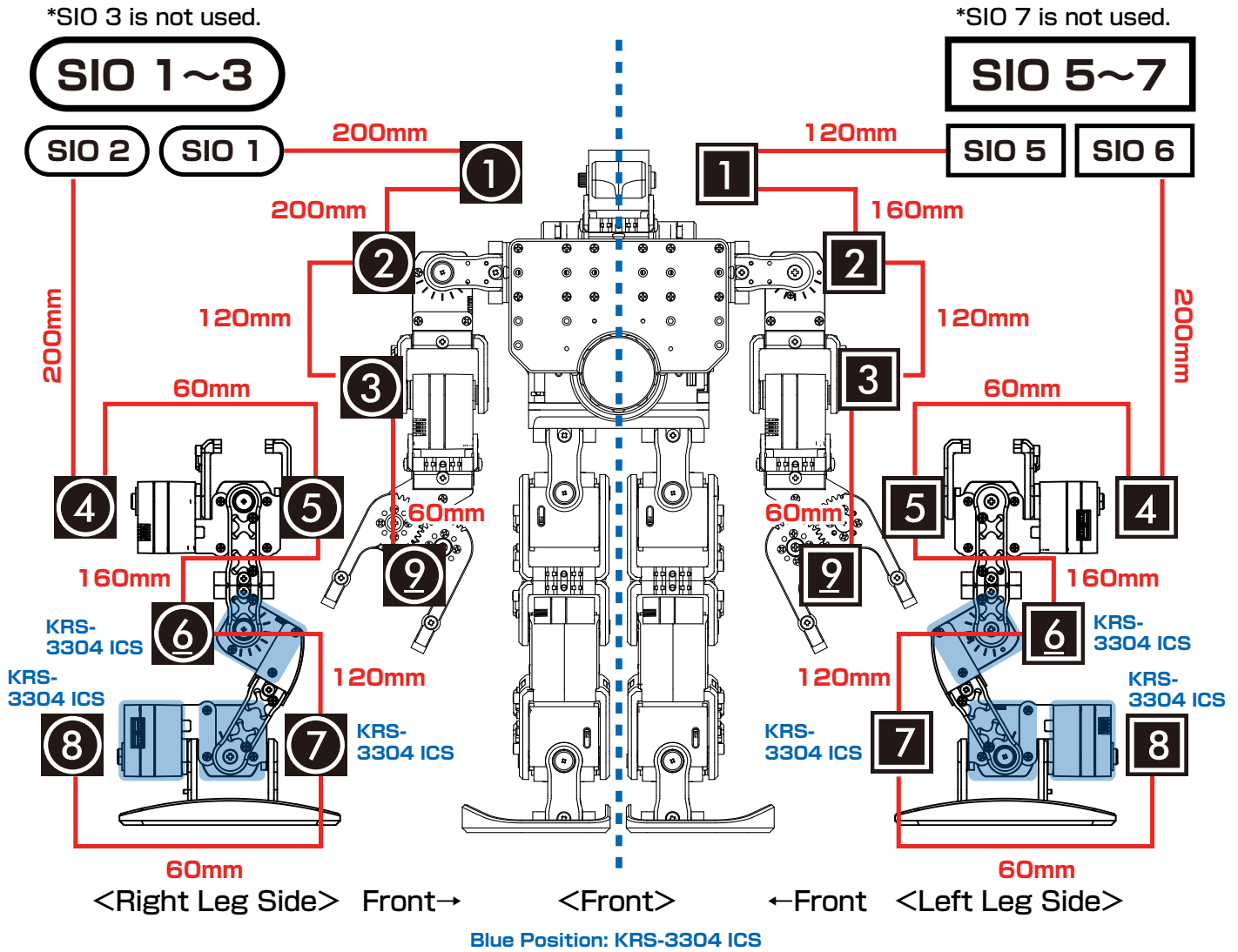

### Putting on Connection Cable Decals

① Remove the decal.

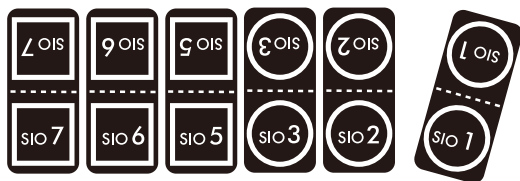

\*Put the number sticker on the blank decal sticker or write on it directly as necessary.

② Put the decal around the cable.

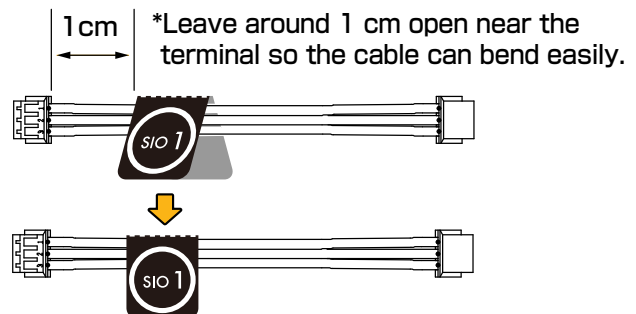

## Procedure 0 Setting Servo IDs

### Procedure 1 Body Assembly

- 1 Multiuse parts
- 2 Neck/Shoulder
- 3 BT Box
- 4 Front Body
- 5 Backpack

### Procedure 2 Arm Assembly

- 1 Gripper
- 2 Shoulder and Elbow
- 3 Attach the Gripper

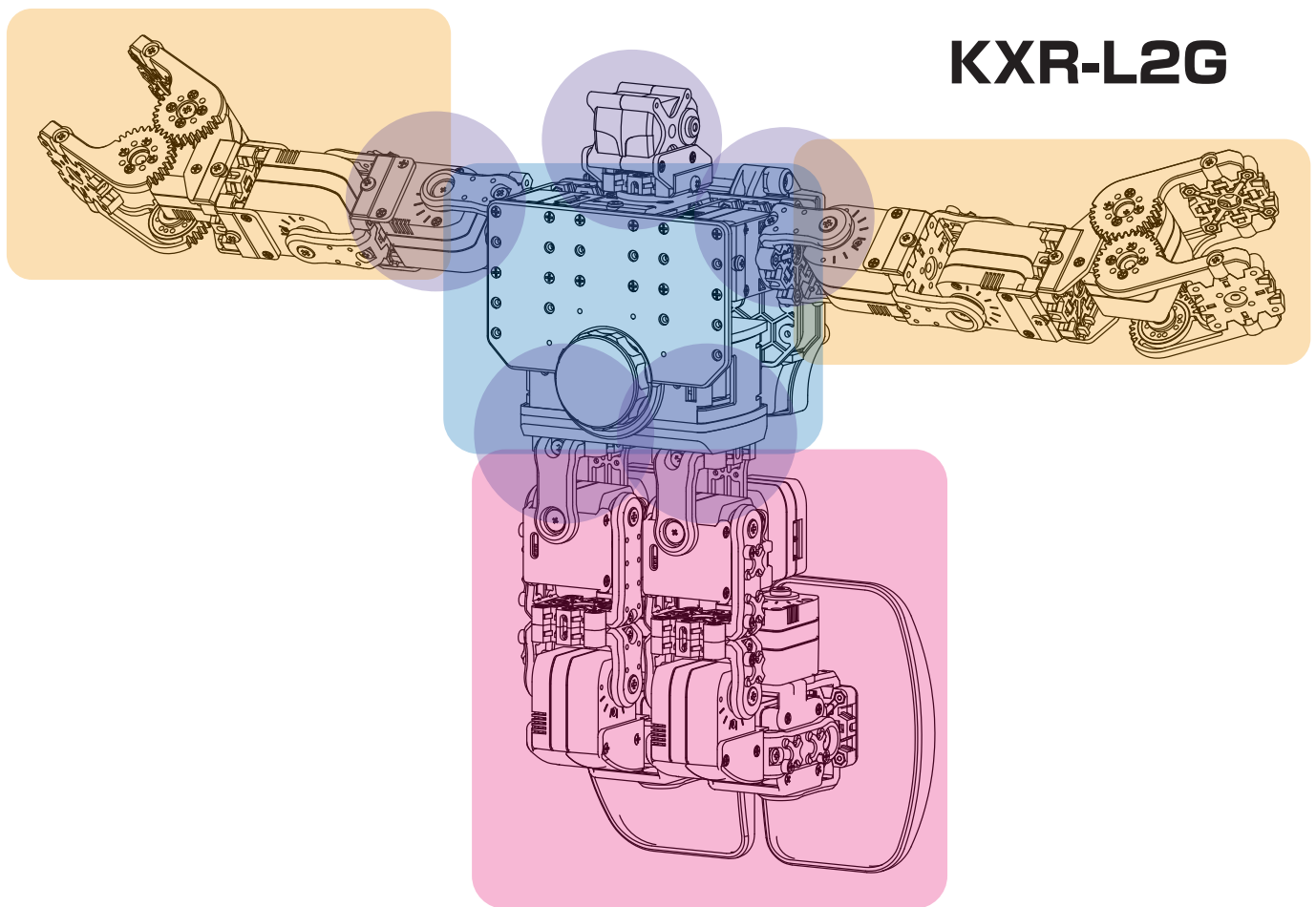

\*Reference diagram

### Procedure 3 Leg Assembly

- 1 Hip Joint
- 2 Ankle and Knee
- 3 Join

### Procedure 4 Full Assembly

- 1 Head
- 2 Right Arm
- 2 Left Arm
- 4 Right Leg
- 5 Left Leg
- 6 Electronic components



## ■ Setting Servo IDs

First, apply ID stickers to the servos.

Example of ID sticker application

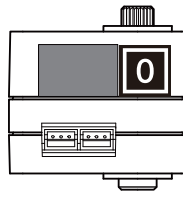

KRS-3301	①	②	③	④	⑤	⑨
x12	1	2	3	4	5	9
KRS-3304	⑥	⑦	⑧			
x6	6	7	8			

## ● KO Driver Installation

1. Set the Dual USB adapter HS switch to ICS mode, connect the Serial Extension Cable, and then plug it into the USB port of your personal computer. When connected to the USB port in ICS mode, the Dual USB Adapter HS LED lights up red.
2. When connected to the Windows PC for the first time, the “Add New Hardware Wizard” will automatically run. Complete the setup following the KO Driver Installation Manual in the USB folder in the included CD-ROM.

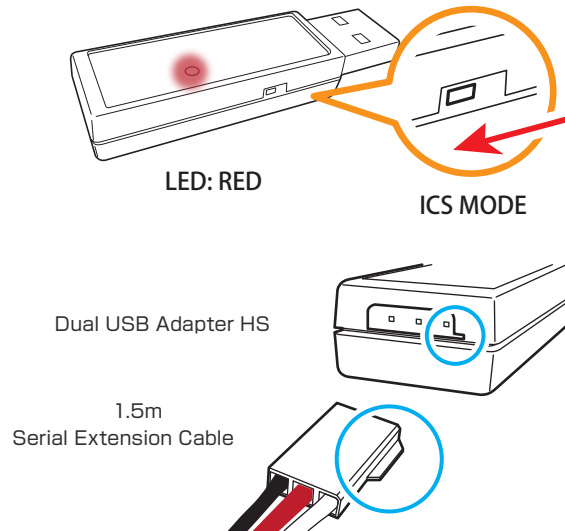

## ● Dual USB Adapter HS COM Confirmation

When the Dual USB Adapter HS driver installation is completed, confirm the “COM Port Number”. This number is important when using the software, so please write it down. The method of confirming the COM number is included in the KO Driver Installation Manual in the USB folder in the included CD-ROM. Point Operation Tips Caution for Breakage Confirmation Required.

## ● Connection

Connect the servos to the Dual USB Adaptor HS and serial extension cable with ZH conversion cable.

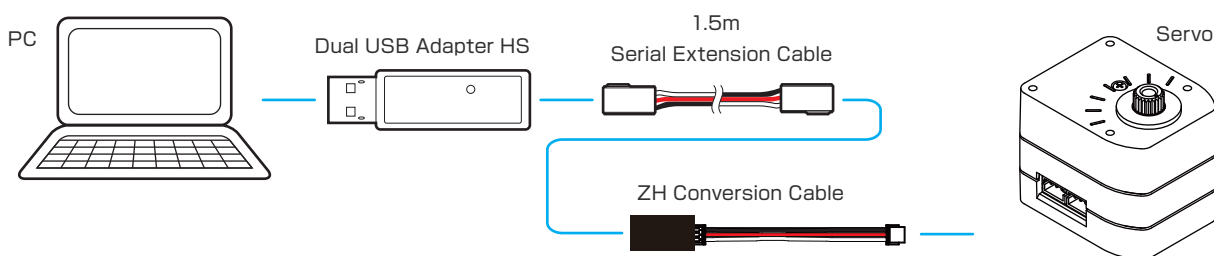

**Be aware that the cable used for connection differs from the software manual.**

## ● Changing Servo ID Settings

1. Copy the Serial Manager folder on the CD-ROM included with the set onto the PC desktop.

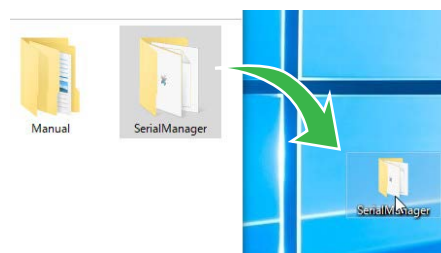

2. Double-click ICS3.5Manager.exe in the copied Serial Manager folder and launch ICS3.5Serial Manager. ICS3.5Serial Manager allows you to change settings for ICS3.5/3.6-spec. servo IDs, rotational mode and various parameters.

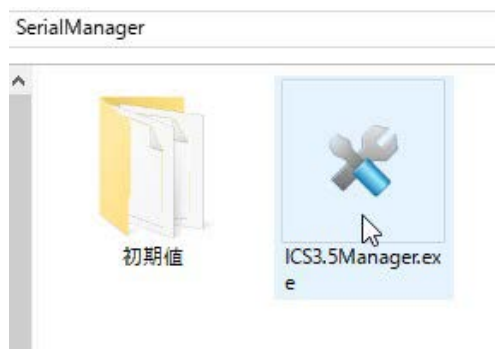

3. Select the COM number confirmed above in “Dual USB Adaptor HS COM Confirmation.” In the image, COM 1 is selected, but the COM number differs depending on the computer you use, so always select the confirmed number.

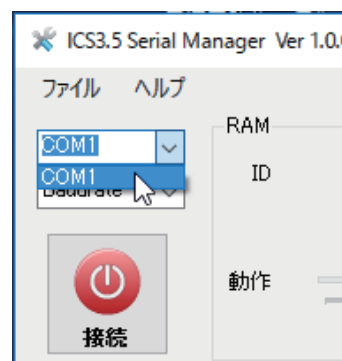

4. Set the speed for servo communications. If you select “Auto,” it will automatically connect in line with the communication speed.

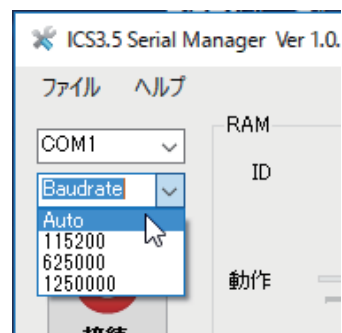

When the communication speed is selected (KRS-3301 ICS at factory shipment is 115200) and the “Connect” button changes to “Disconnect,” the process is complete. When the connection is complete, the IDs will automatically switch based on the servos.

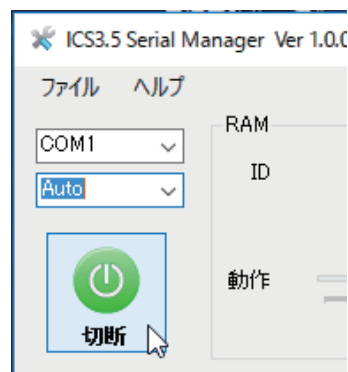

The ○ and □ mark on the ID sticker is unrelated to the ID, so confirm only the number.

5. Select the set ID number from the “ID” pull-down menu.

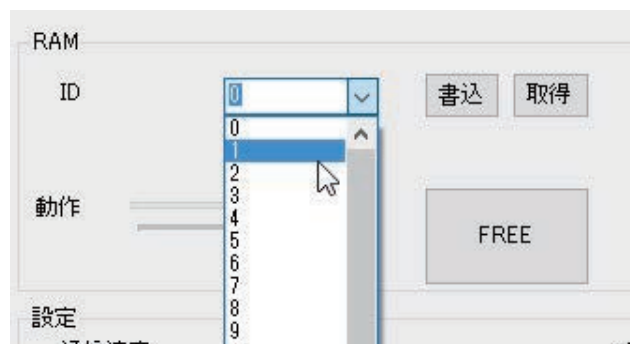

6. Press the “Write” button on the “ID” menu and write the ID onto the servo.

If successful, “ID: Write Complete” will be displayed in the lower-left box.

If it fails, “Communication Failed” will be displayed, so confirm the procedures and press the “Write” button again. In particular, be sure that Dual USB Adaptor HS is in “Serial Mode.”

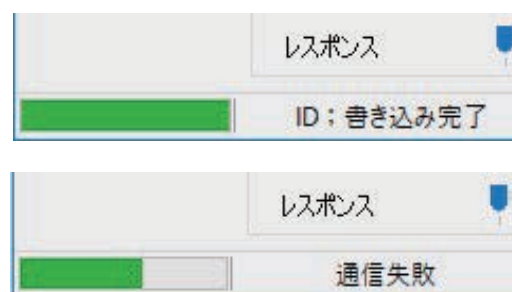
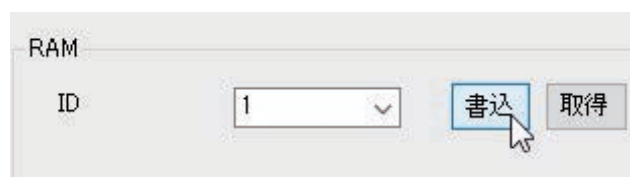

7. Just to be sure, confirm the ID. When you press the “Acquire” button, the written ID will be displayed in the pull-down menu.

Confirm that “ID: Acquire Complete” is displayed in the lower-left, and confirm that the correct ID is displayed in the pull-down menu.

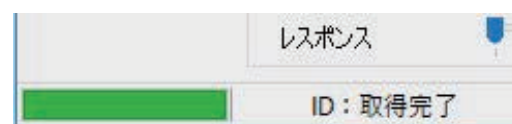
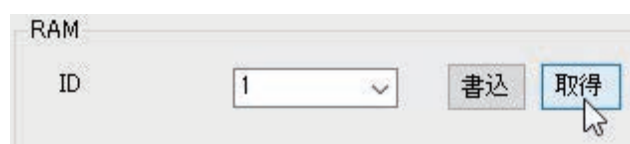

The above is the method for changing “Servo ID” settings. When all of the processes are completed, always remove the Dual USB Adaptor HS from the PC after closing the software.

\*This process is only for changing settings, so communications use the PC’s bus power, but when confirming operations, connect the battery. Refer to the manual included with Servo Manager for information on the connection method and necessary cable types.

## Assemble all the multiuse parts.

### Parts used

- Dummy servo-Upper x2
- Dummy Servo-Bottom x2
- Joint Base x24
- Joint Nut x24
- (First assemble 22 sets.)

**A D**

### ① Assemble Dummy servo.

**Dummy servo : 2 (Head / Neck / Hand)**

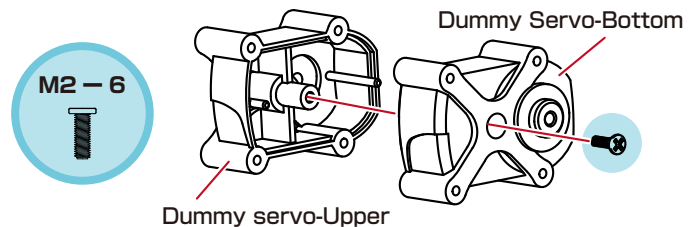

### ② Attach Joint nut to Joint base.

**Joint base A : 17 (Body / Arm / Leg)**

Joint nut screw holes

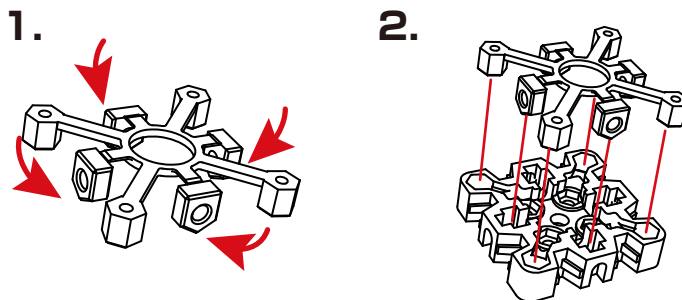
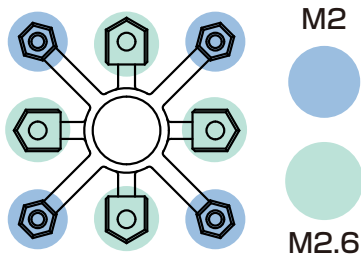

**Joint base B: 2 (Wrist)**

1. Cut 4 M2 parts.

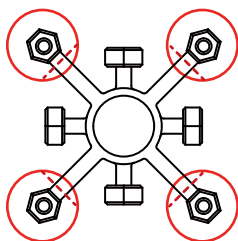

2.

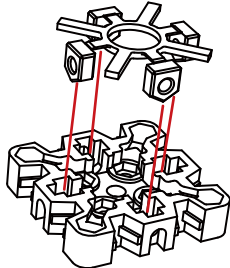

**Joint base C: 1 (Neck)**

1. Cut 2 M2.6 parts.

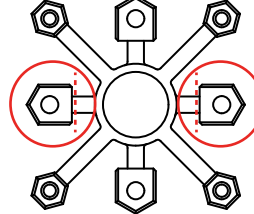

2.

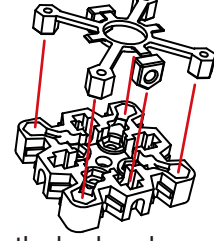

Use the cut M2.6 parts to attach the backpack cover. Store these together with the backpack.

**Double joint base: 2 (Leg)**

1. Cut all.

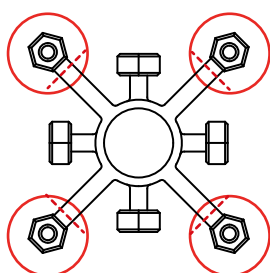

2. Secure two joint bases with screws.

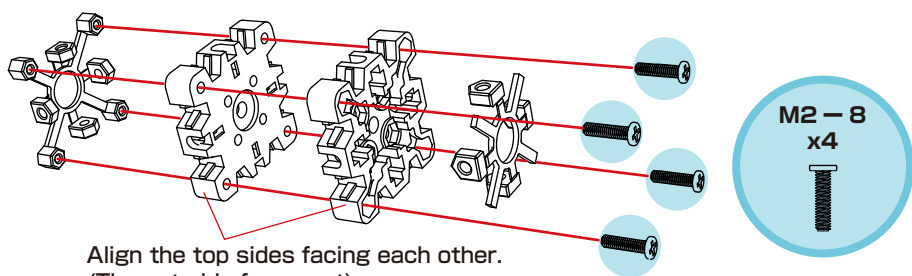

## Assemble all the multiuse parts.

### Parts used

- Joint Frame 3300A x4
- Joint Frame 3300B-a x2
- Joint Frame 3300B-b x2
- Joint Base A x4  
(Assembled)
- M2.6 – 10 x4

## B

### 1

#### Joint base +Frame A: 2 (Arm)

①-1. Attach the Joint Frame 3300A.

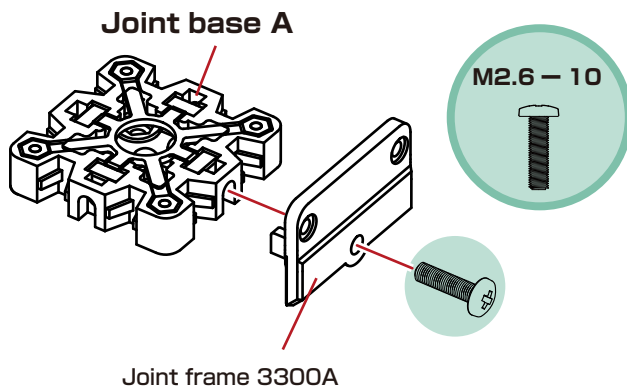

①-2. Attach the otherside.

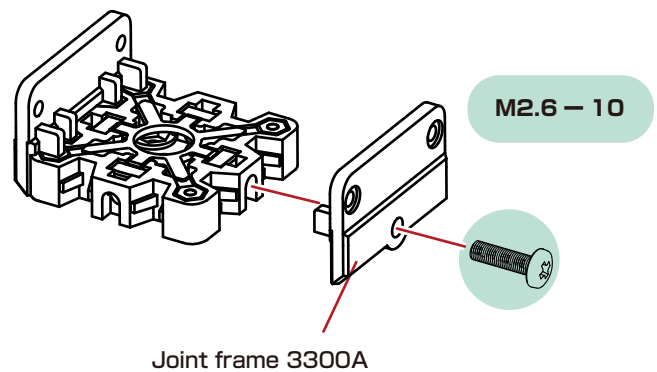

### 2

#### Joint base +Frame B: 2 (Wrist)

②-1. Attach the Joint Frame 3300B-a.

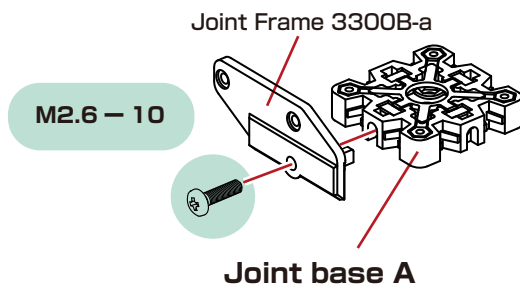

②-2. Attach the Joint Frame 3300B-b.

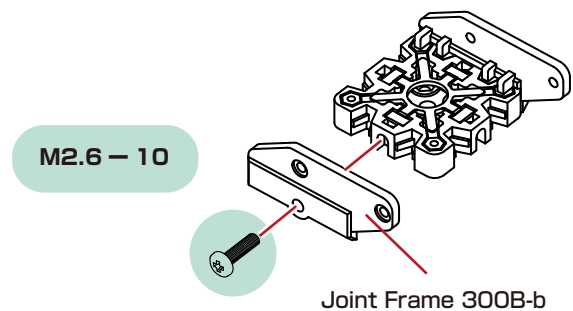

## Assemble the neck servo unit

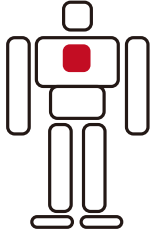
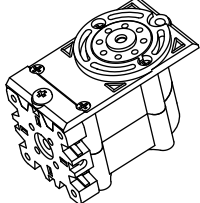
Parts used	Assemble part	Assembly parts completed
<ul style="list-style-type: none"> <li>○ Dummy servo x1 (Assembled)</li> <li>○ Arm supporter 3300A x1</li> <li>○ Joint Base B x1 (Assembled)</li> <li>○ Horn B x1</li> <li>○ M2-6 x4</li> <li>○ M2.6-10 x1</li> </ul>		<p style="text-align: center;"><b>Neck dummy servo unit</b></p> 
<div style="display: flex; gap: 10px;"> <div style="border: 1px solid black; border-radius: 50%; width: 30px; height: 30px; display: flex; align-items: center; justify-content: center; background-color: #0070C0; color: white; font-weight: bold; font-size: 20px;">B</div> <div style="border: 1px solid black; border-radius: 50%; width: 30px; height: 30px; display: flex; align-items: center; justify-content: center; background-color: #0070C0; color: white; font-weight: bold; font-size: 20px;">D</div> </div>		

1

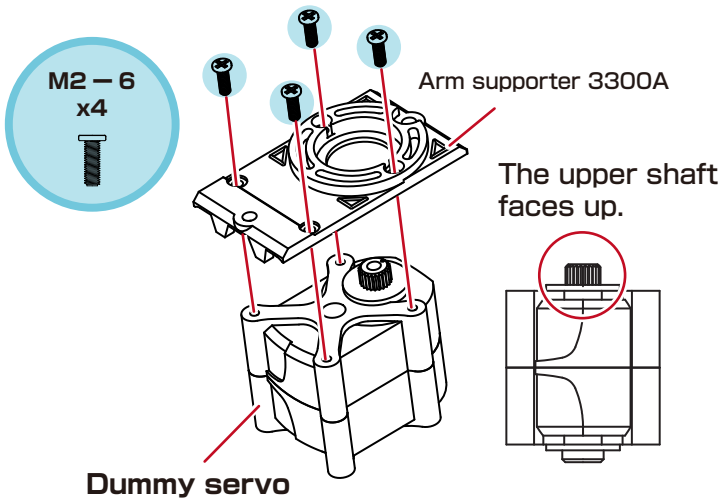

2

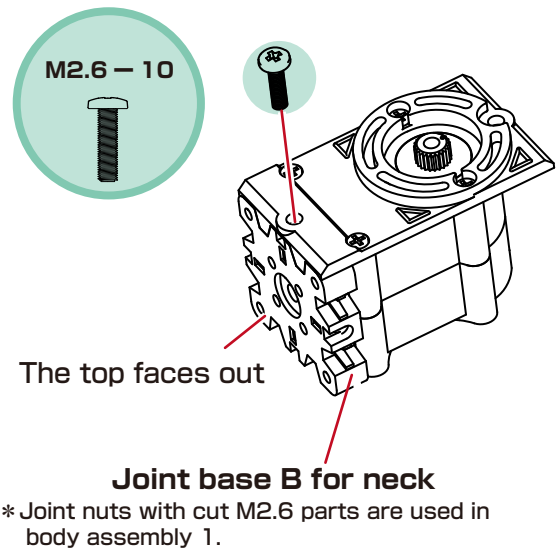

3

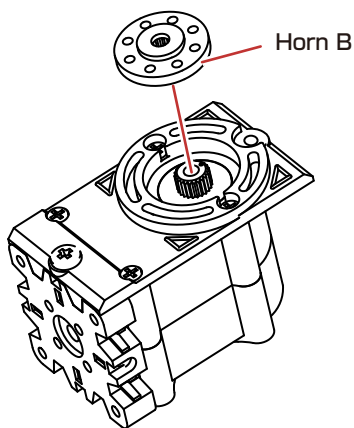

### Points on Attaching to Upper Shaft

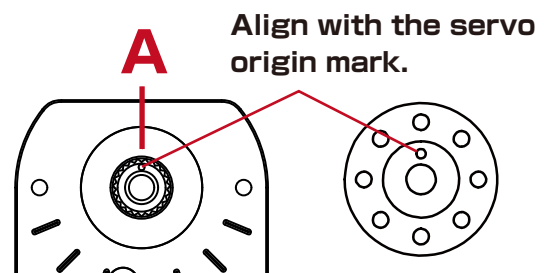

When the origin deviates with the diagram position, lightly insert the arm and rotate to adjust the position. Attach it straight toward the A line.



## Assemble the right shoulder servo unit.

### Parts used

- Servo (ID 1)
- Arm supporter 3300A x2
- Joint base A x2 (Assembled)
- M2-6 x4
- M2.6-10 x4

### Assemble part

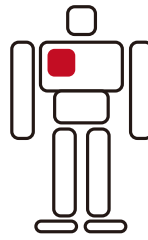

### Assembly parts completed

Right shoulder servo unit

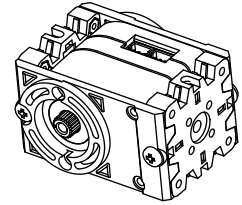

**B** **1**

**1**

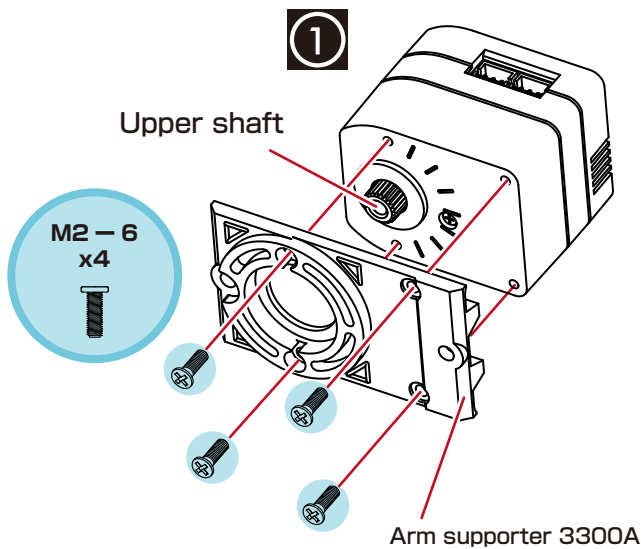

**2**

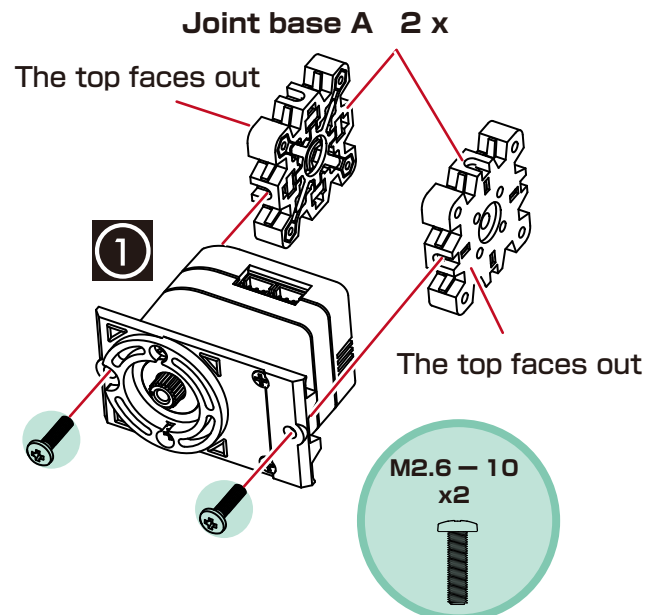

**3** Detach case screws.

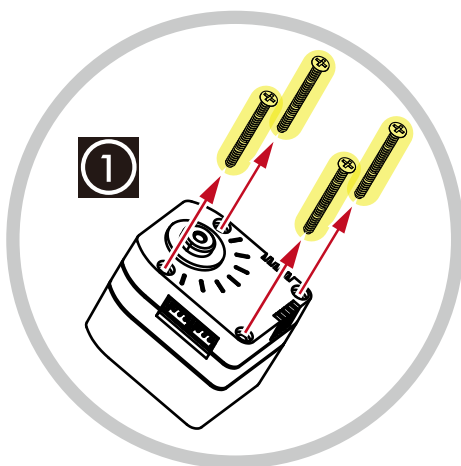

**4**

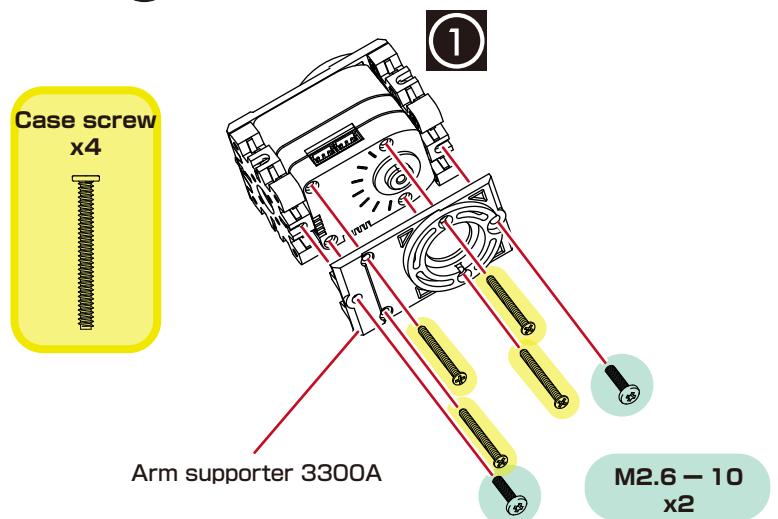

## Assemble the left shoulder servo unit.

### Parts used

- Servo (ID 1)
- Arm supporter 3300A x2
- Joint base A x2 (Assembled)
- M2-6 x4
- M2.6-10 x4

### Assemble part

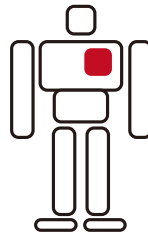

### Assembly parts completed

Left shoulder servo unit

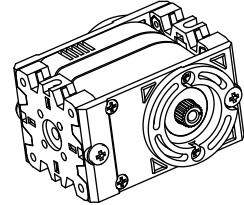

**B** **1**

①

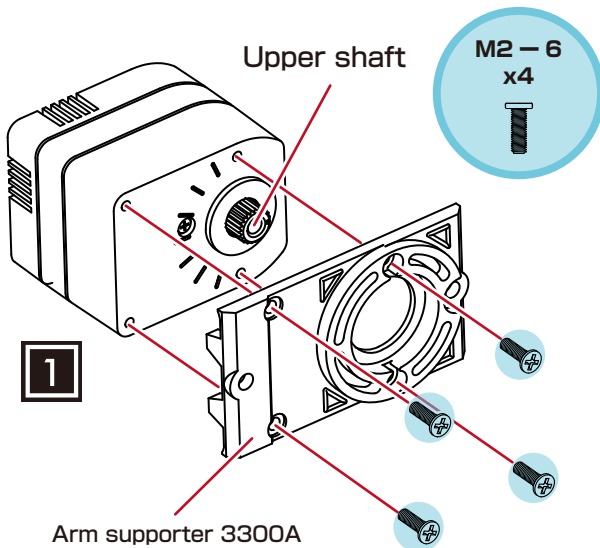

②

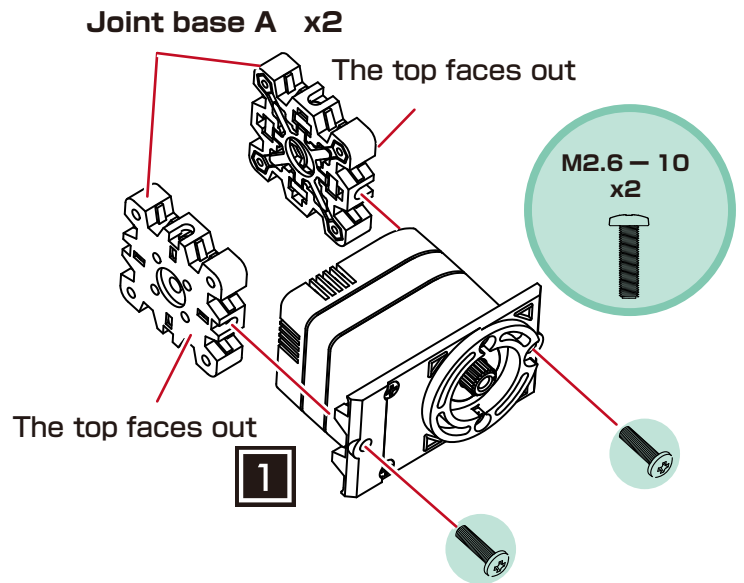

③ Detach case screws.

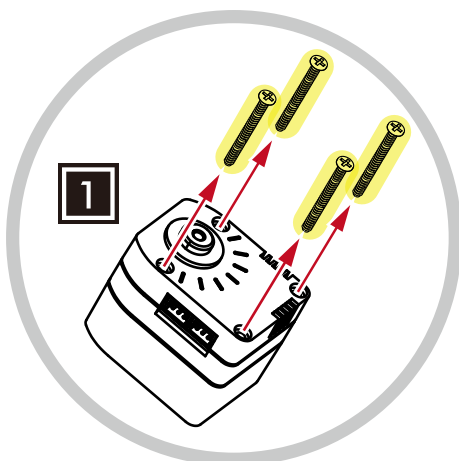

④

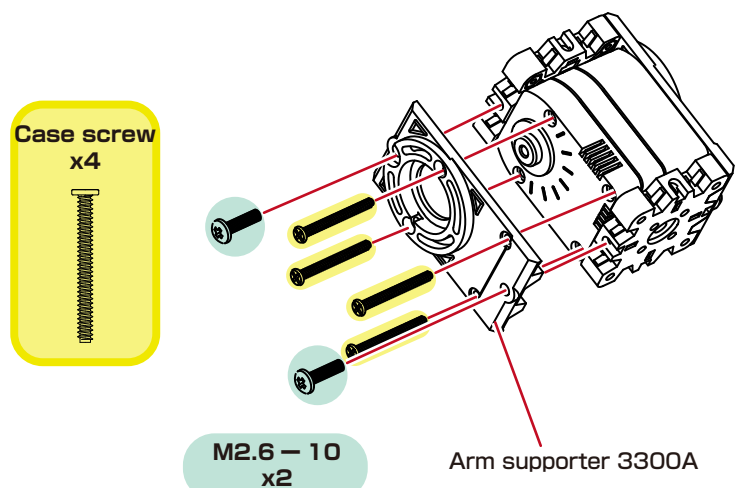

## Assemble by wiring through the BT (Battery) box.

### Parts used

- BT Box plate x2
- BT Side plate x2
- BT Hatch x2
- M2-6 x8
- ZH connection cable 2
  - 120mm x1
  - 200mm x3
- Decale

### Assemble part

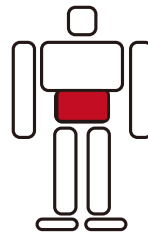

### Assembly parts completed

BT ボックス

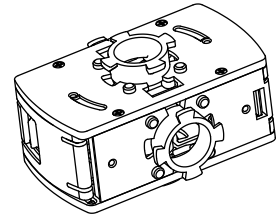

F

① Wire two ZH connection cables of 200 mm and 120 mm to the BT box plate.

①-1.

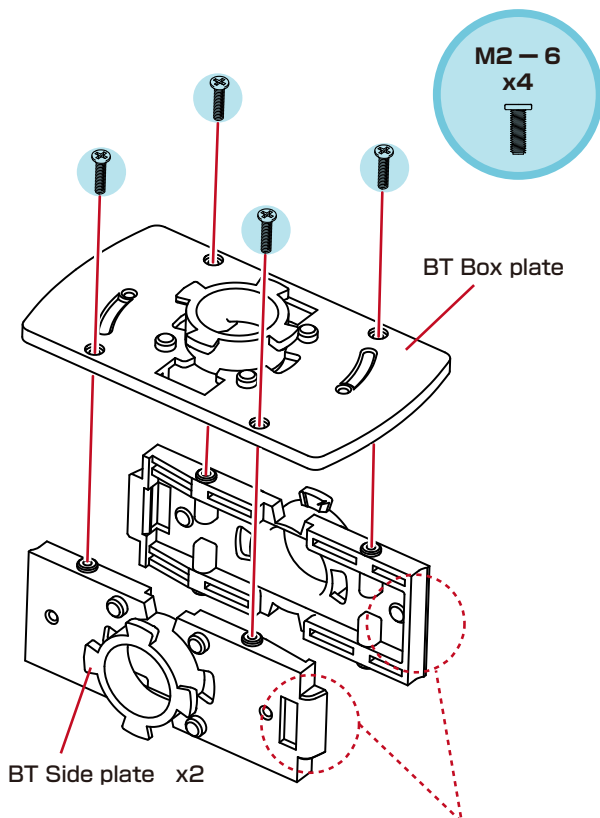

**\* Make sure the direction of the BT side plate is correct.**

①-2. Pull the cable to the length indicated below.

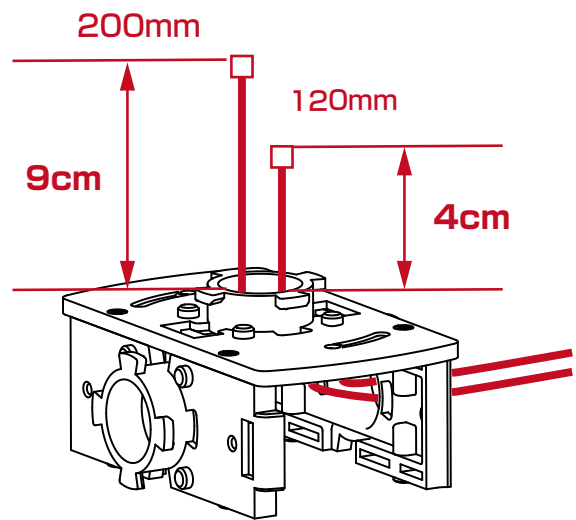

①-3. Wire the cable with the hook gap in a vertical position and store under the hook.

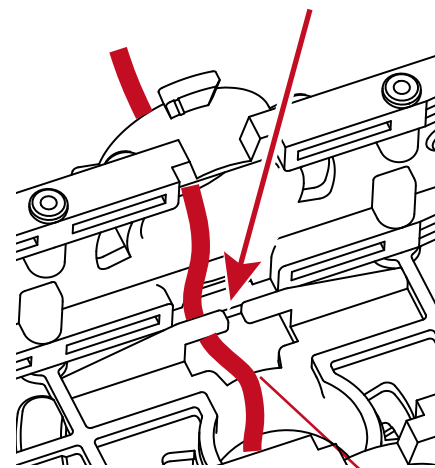

ZH-ZH Connection cable

①-4. Secure with tape, etc. so it doesn't come out easily.

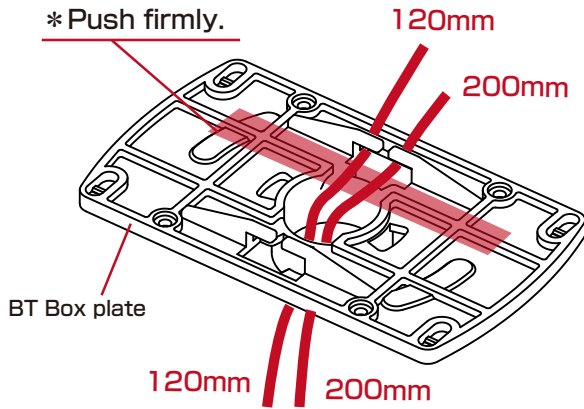

\* As seen upside down

①-5. Apply the decal to the cable.

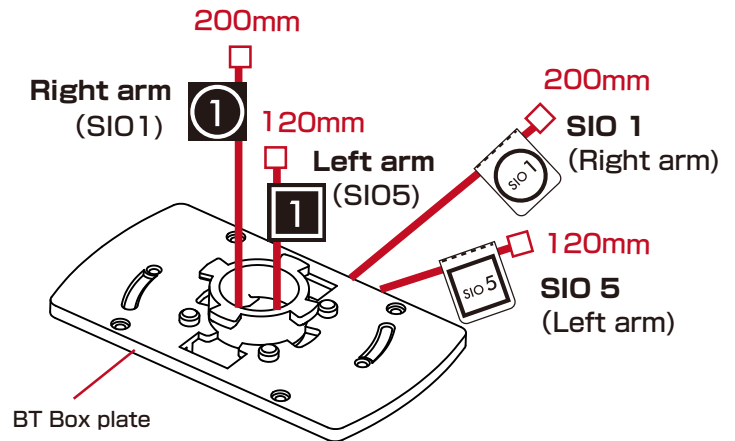

\* As seen from the top

(The diagram is only of the BT box plate so that it is easy to view.)

② Wire two 200 mm ZH-ZH connection cables to the other BT box plate.

②-1. Pull the cable to the length indicated below.

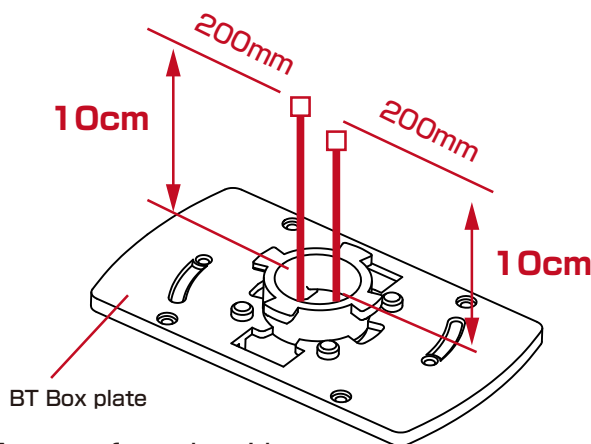

\* As seen from the side:  
When complete, this is on the bottom.

②-2. Secure with tape, etc. so it doesn't come out easily.

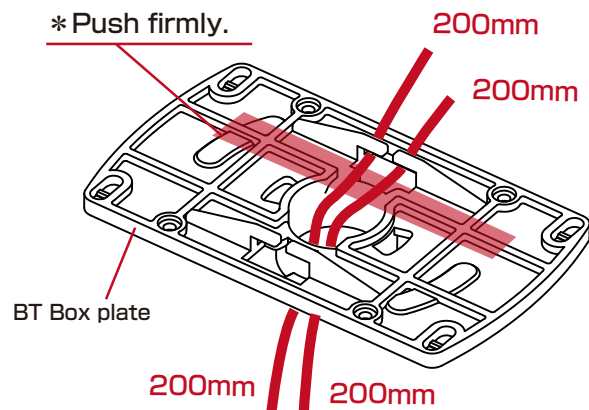

\* As seen upside down

②-3. Apply the decal to the cable.

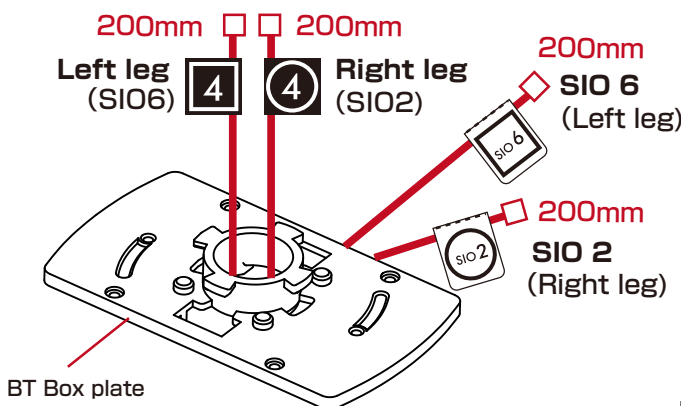

\* As seen from the bottom

②-4. Assemble by wiring through the BT box.

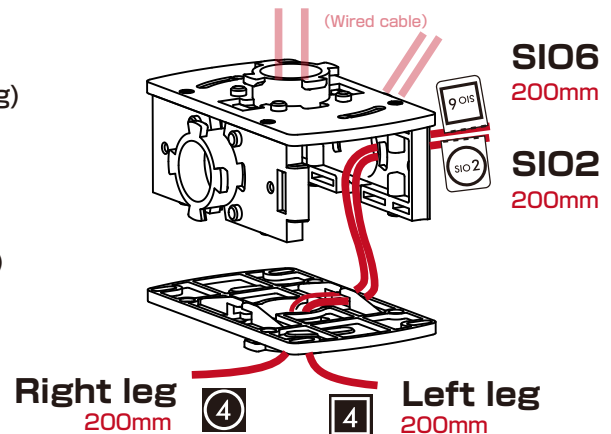

- ⑤ Attach the plate on the opposite side so that it sandwiches the two BT hatch plates.

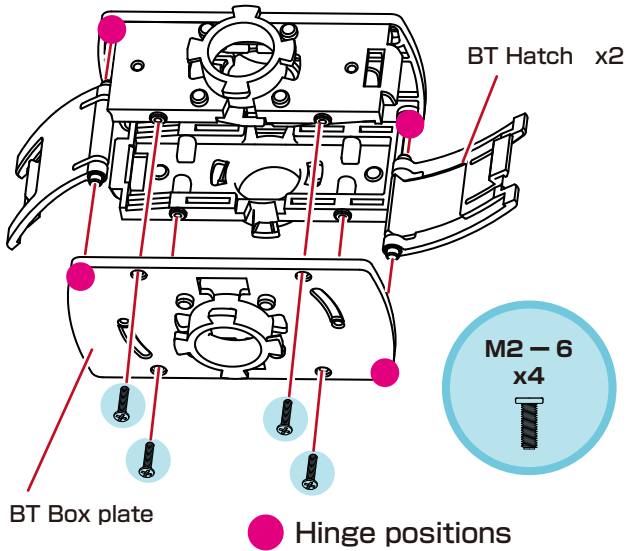

\* If installation proves difficult, try temporarily securing the BT box plate and inserting one BT hatch at a time.

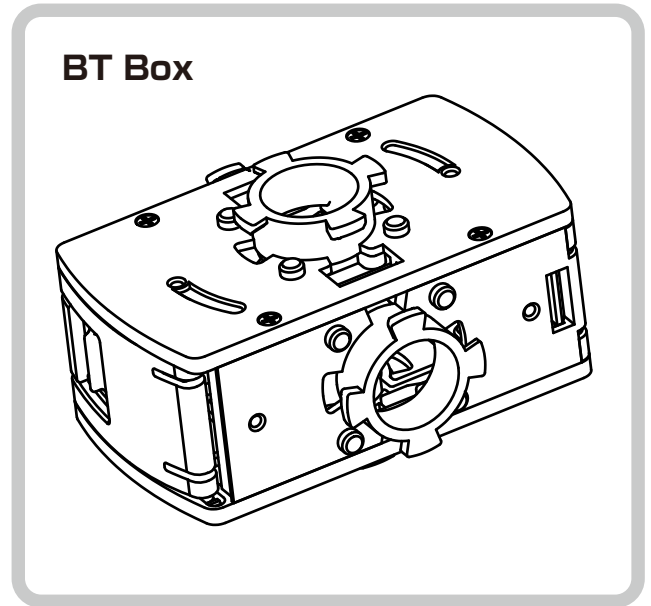

## Opening/closing hatch

Both sides open the same way.

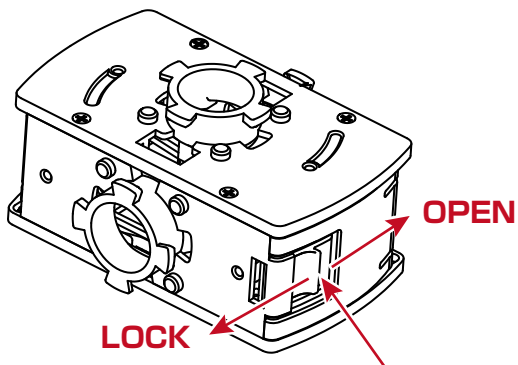

Push and slide.

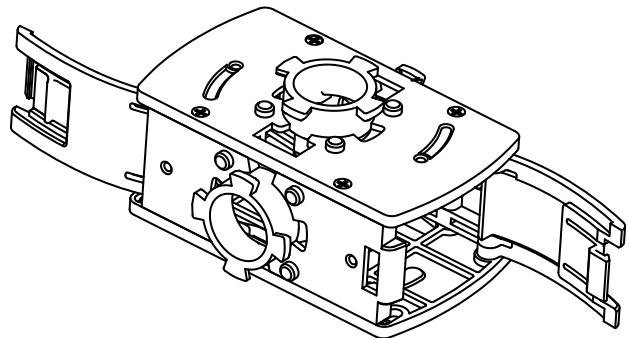

## Assemble the body parts on the front side.

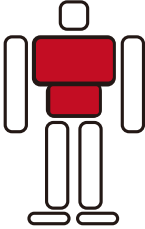
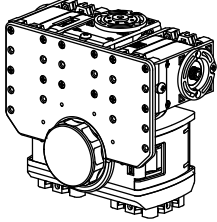
Parts used		Assemble part	Assembly parts completed
<ul style="list-style-type: none"> <li>○ BT Leg plate x1</li> <li>○ Body panel x1</li> <li>○ Panel spacer x1</li> <li>○ Lock ring x1</li> <li>○ Lock ring cap x1</li> <li>○ Joint base A x2 (Assembled)</li> </ul>	<ul style="list-style-type: none"> <li>○ M2 - 8 x20</li> <li>○ ZH Connection cable 2 160mm x1 200mm x1</li> </ul>		<p><b>Front body</b></p> 



## Attach the BT leg plate and front side body panel.

**①**

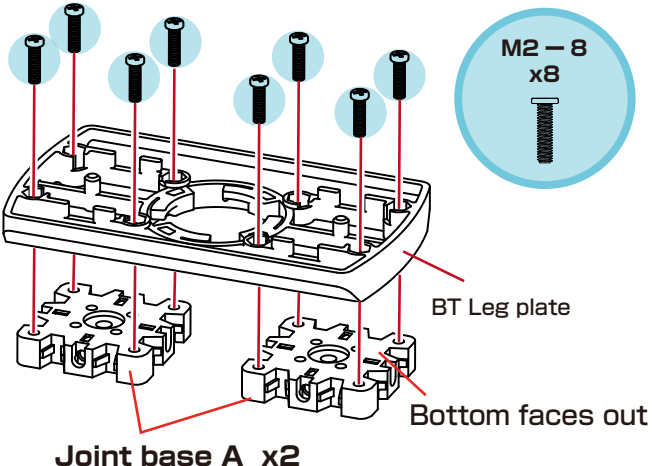

**②**

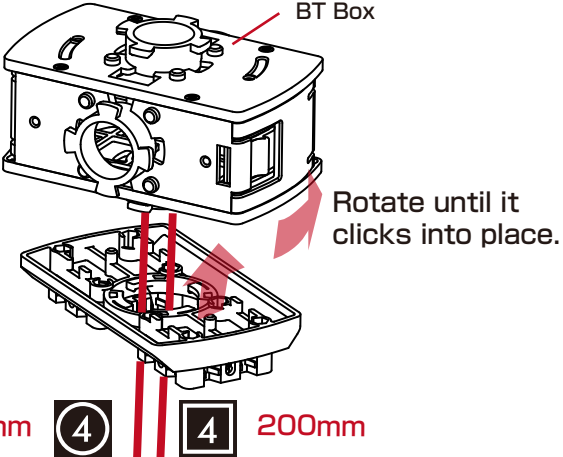

\* Assemble by wiring through the BT Leg plate.

### About the lock portion for the BT box and body parts

- ① Align the notch and protrusion, and attach.      ② Rotate until it clicks into place.

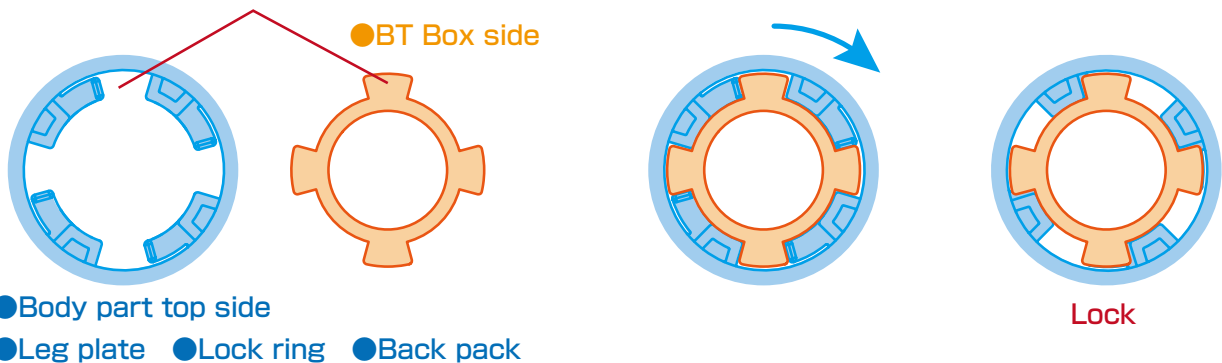



3

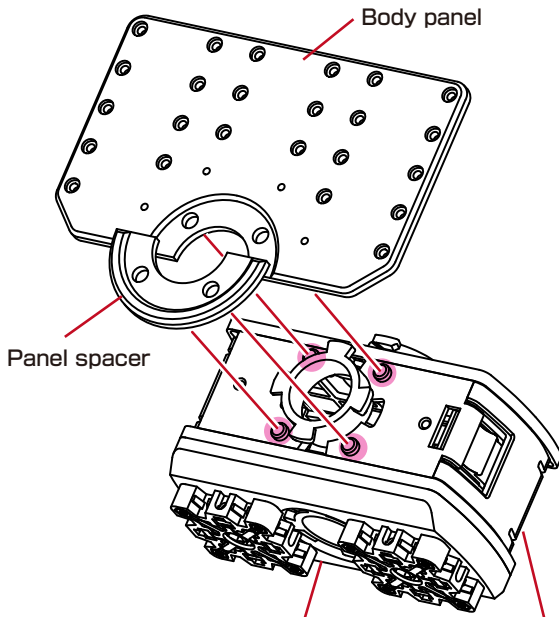

\* The BT leg plate is on the bottom side.

\* The four cables go on the rear side.

4

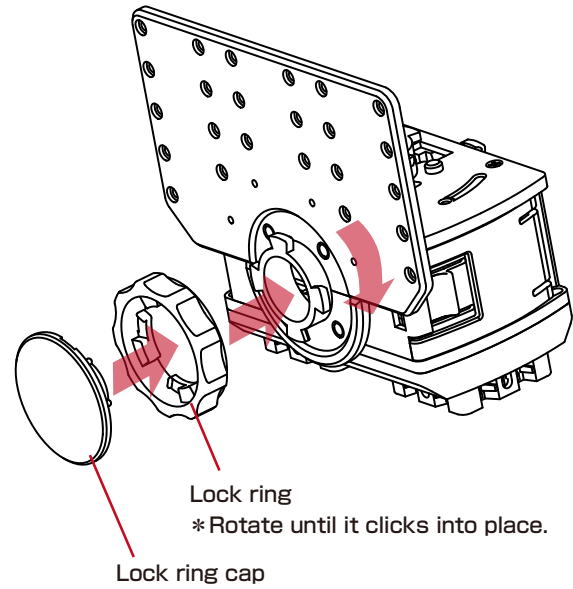

Lock ring

\* Rotate until it clicks into place.

Lock ring cap

## ■ Attach the servo units for both shoulders and the neck.

1

Right shoulder

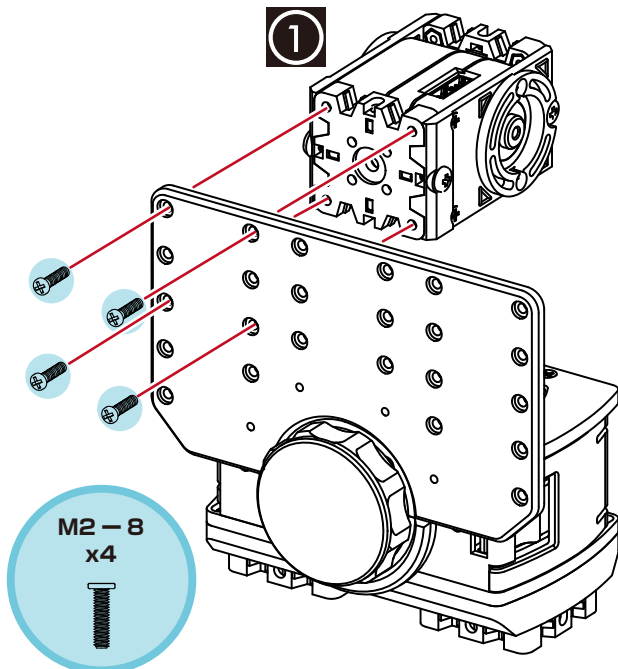

M2-8  
x4

2

\* Whichever connector is used, it has no effect on operations, but be sure the cable is not overlapped or pinched.

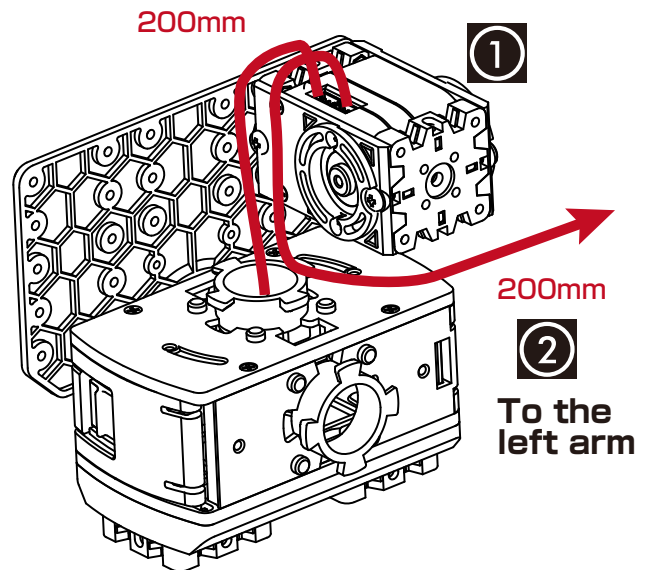

200mm

To the left arm

\* When combined, connect to the right arm. Put it on the outer side of the body.

3

\* Whichever connector is used, it has no effect on operations, but be sure the cable is not overlapped or pinched.

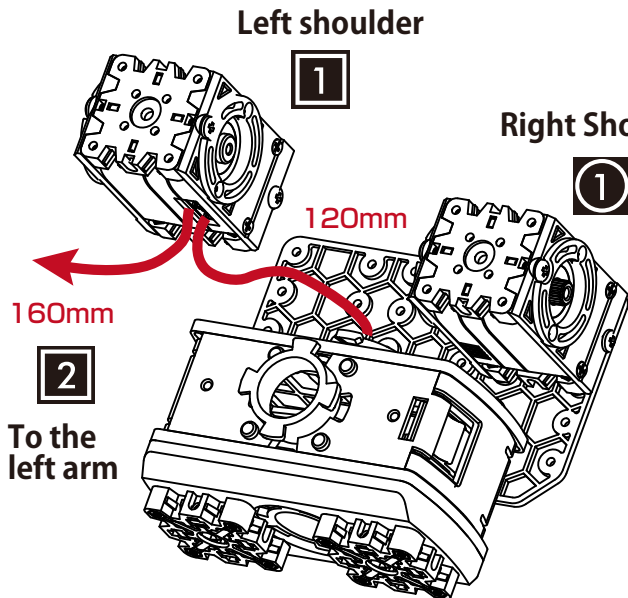

\* When combined, connect to the left arm. Put it on the outer side of the body.

4

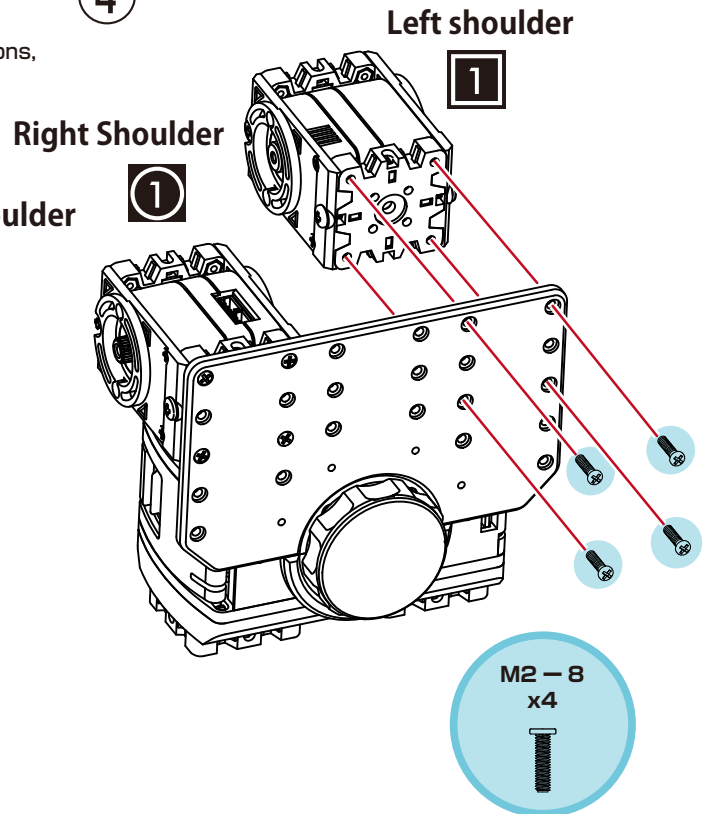

5

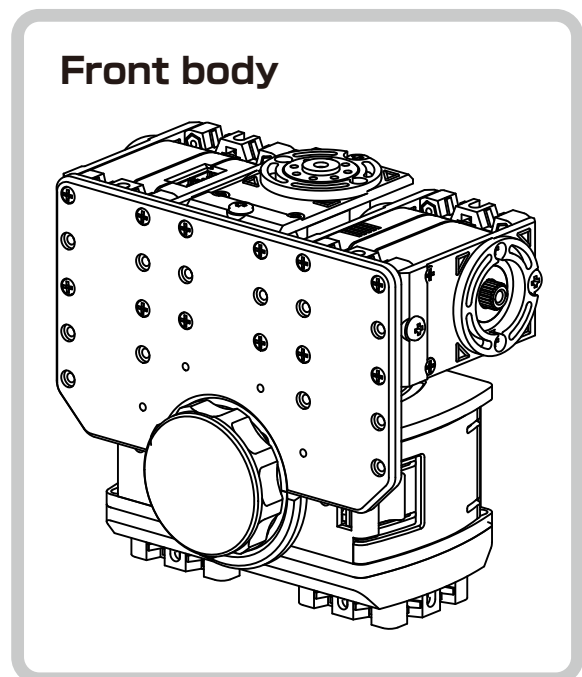
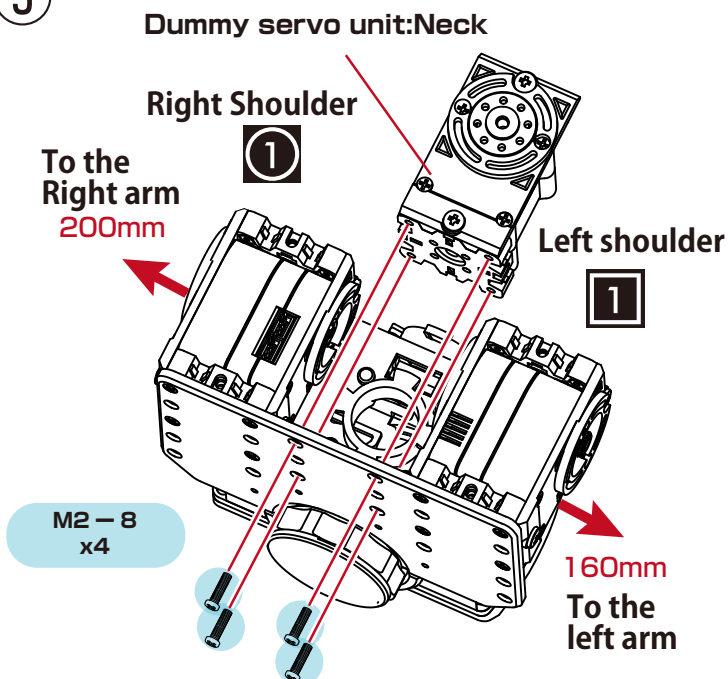

## ■ Attach the back side body panel and backpack.

### Parts used

- Backpack base x1
- Backpack cover x1
- Body panel x1
- Panel spacer x1
- Joint base A x1
- Joint base A x1 (Assembled)
- M2-6 x2
- M2-8 x12
- M2.6-10 x3
- M2.6 Nut x2 (Already cut in "Body Assembly 1")

**E G**

### Assemble part

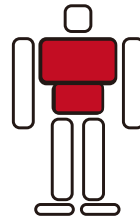

### Assembly parts completed

#### Backpack

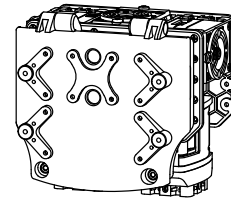

1

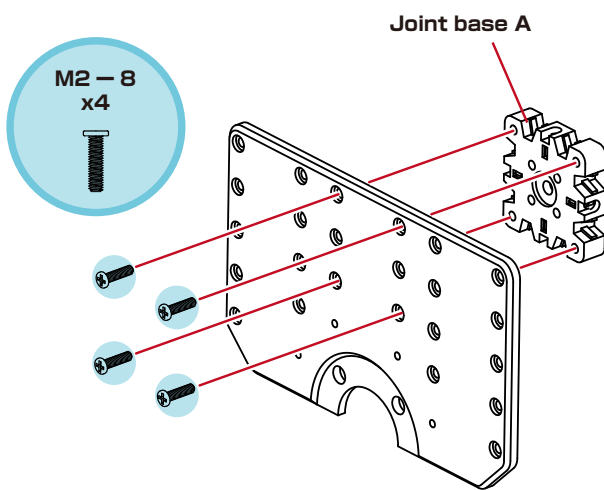

2

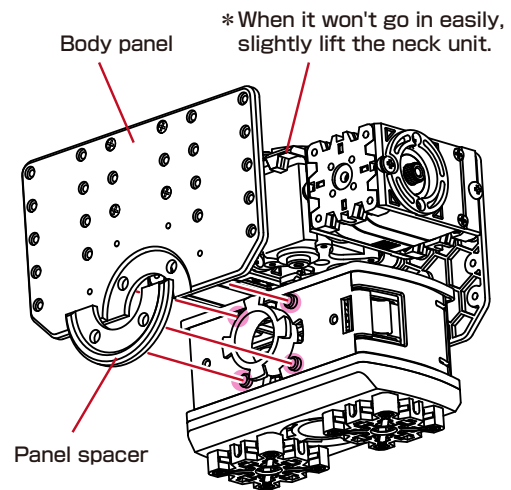

3

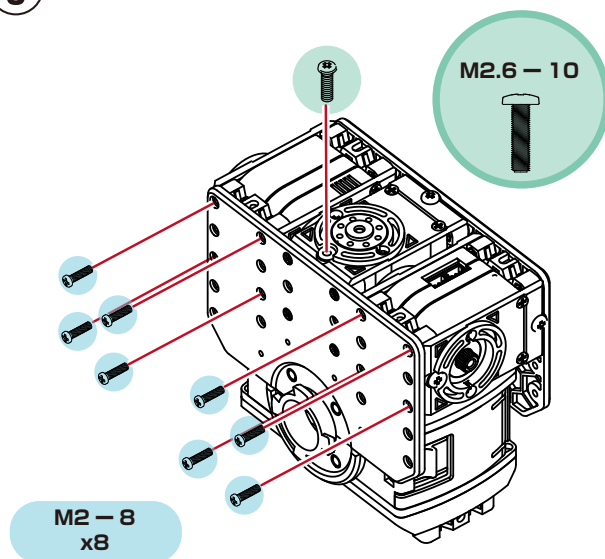

4

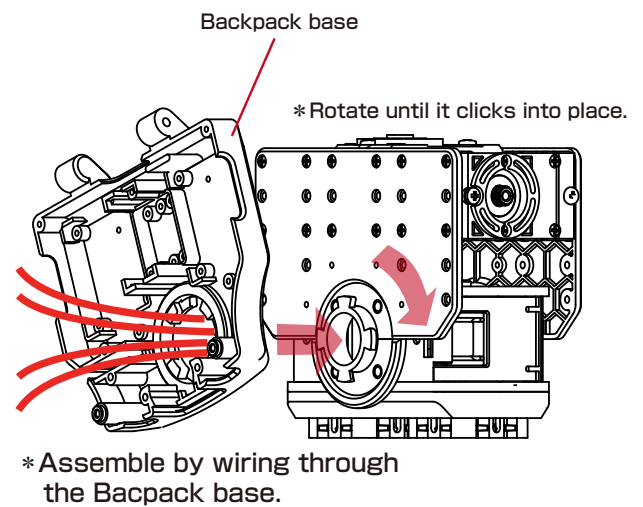

5

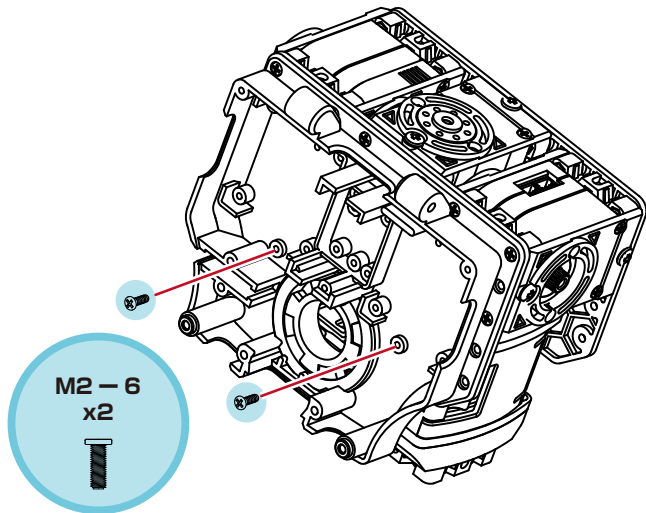

6

6-1.

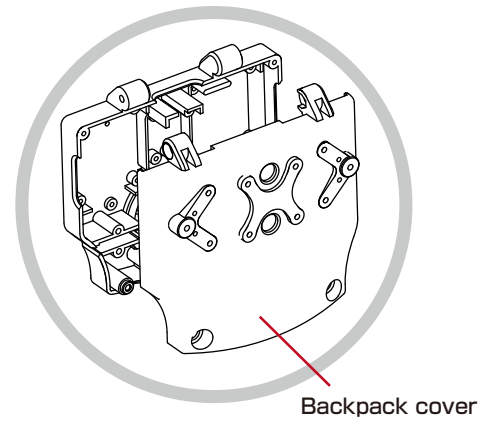

6-2.

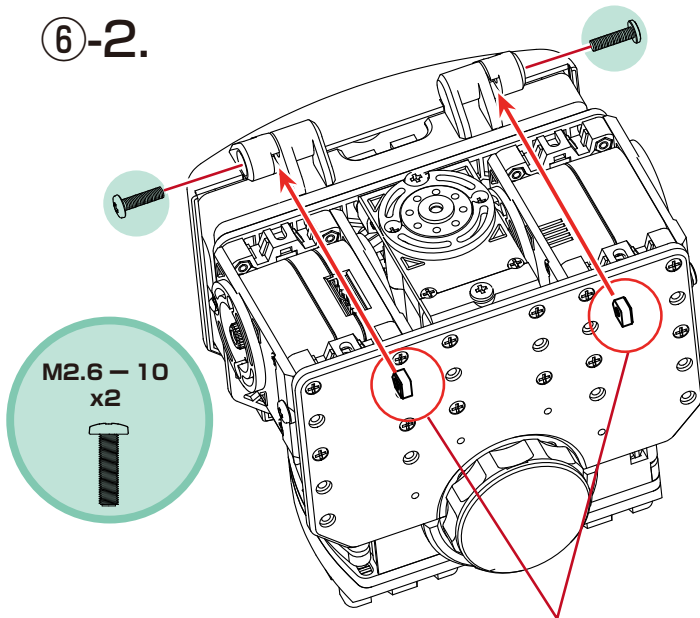

The screw side (facing out) is the side with beveling around the holes.

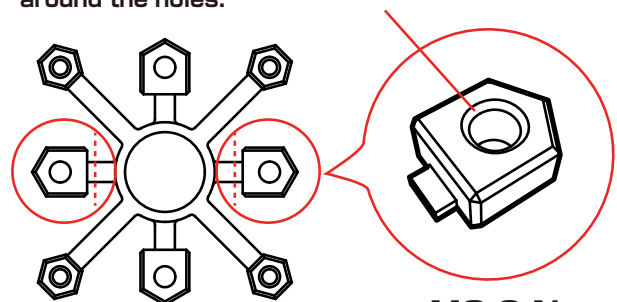

Use the M2.6 part of joint nuts cut when making the neck.

Body

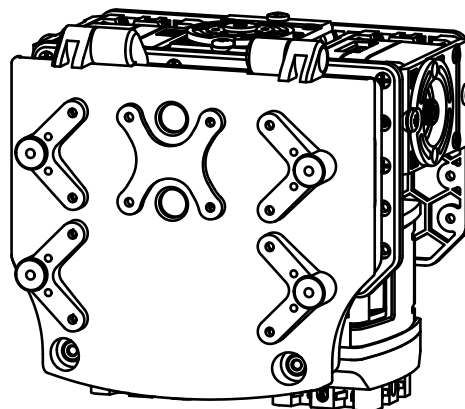

## Assemble the neck servo unit

### Parts used

- Servo (ID9) x2
- Joint frame 3300A x4
- Gripper A-a x4
- Gripper A-b x4
- Bush x4
- Spacer x4
- Joint Base A x4 (Assembled)
- Joint Base B x2 (Assembled)
- Joint Base + Frame B x2 (Assembled)
- Horn B x2
- Free horn C x6
- M2-4 x32
- M2-6 x6
- M2-8 x8
- M2.6-10 x12
- M3-6 x2
- 2.6-4 x2

### Assemble part

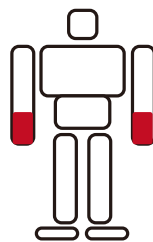

### Assembly parts completed

#### Gripper

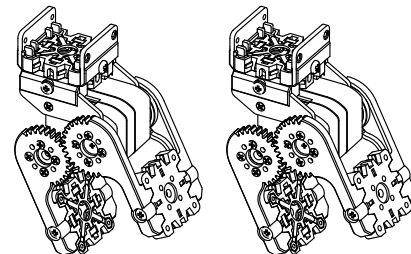

Assemble 2 sets.

① Detach case screw.

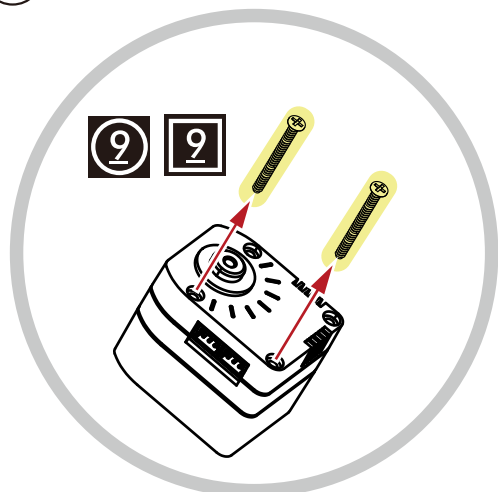

②

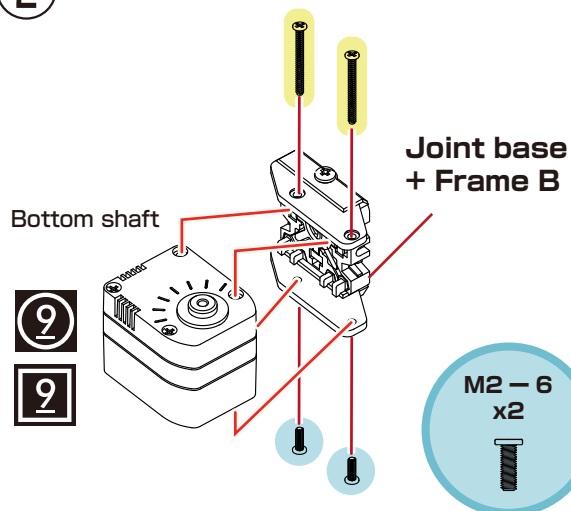
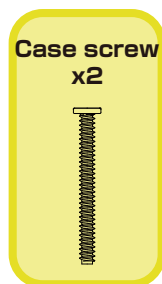

③

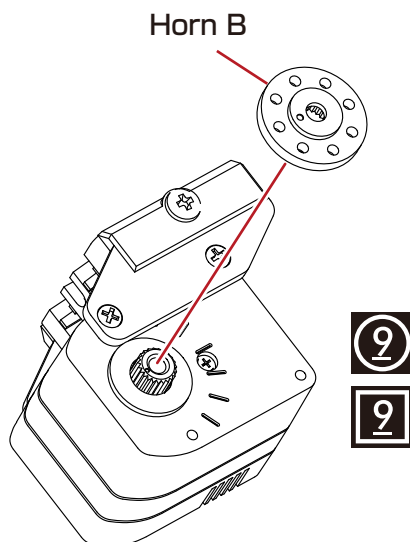

### Points on Attaching to Upper Shaft

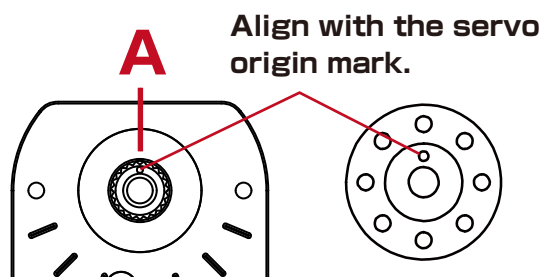

When the origin deviates with the diagram position, lightly insert the arm and rotate to adjust the position. Attach it straight toward the A line.



4

4-1. Attach the gripper A-a.

<Installation Angle Reference Diagram>

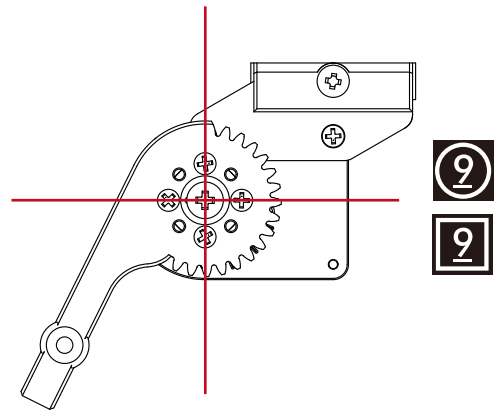
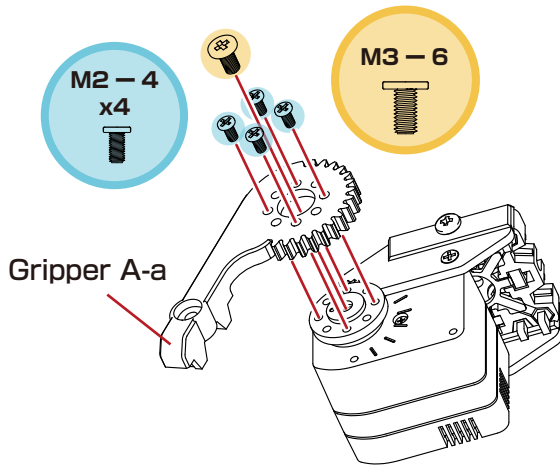

4-2. Attach the free horn C.

4-3. Attach the gripper A-b

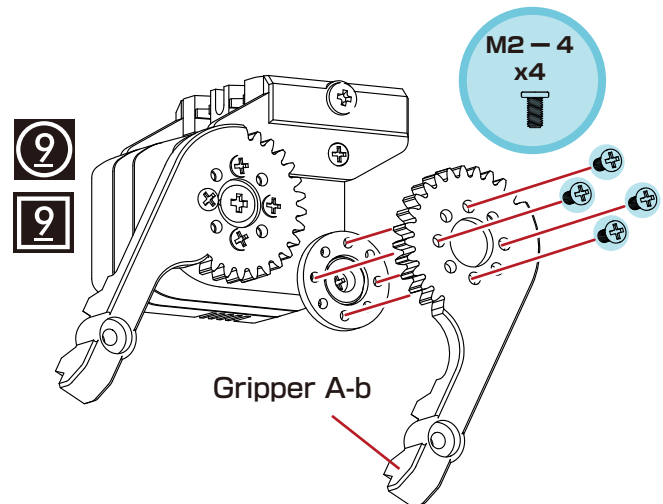
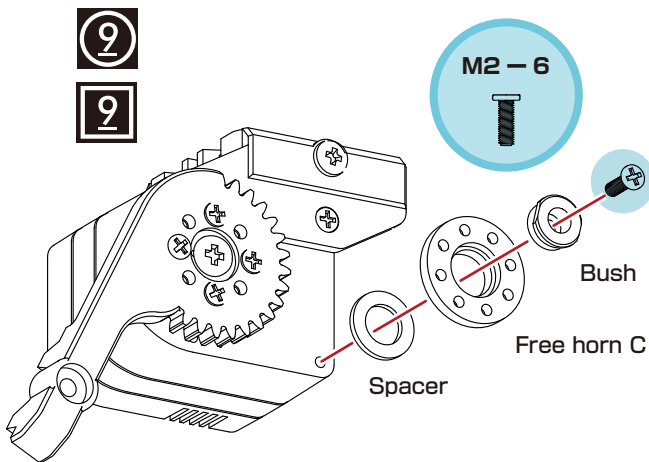

<Installation Angle Reference Diagram>

5

5-1. Attach the free horn C and joint base A to the gripper A-b.

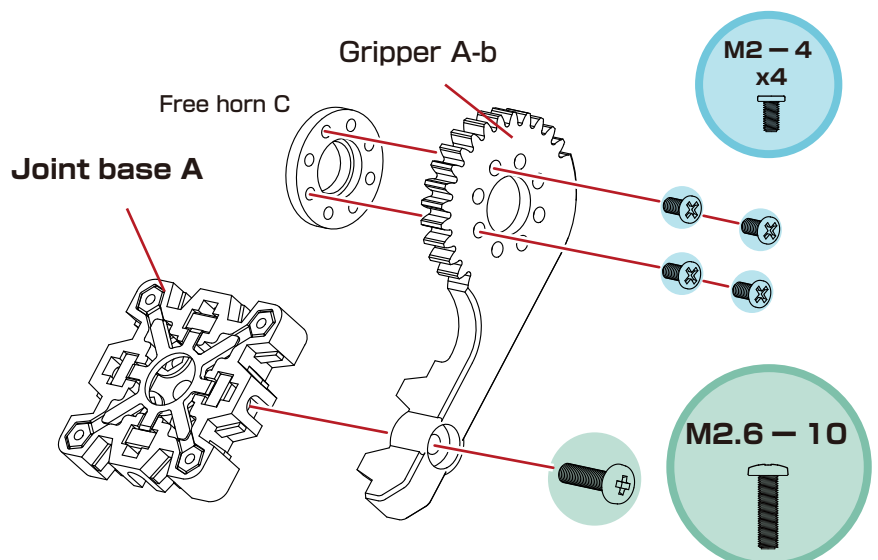
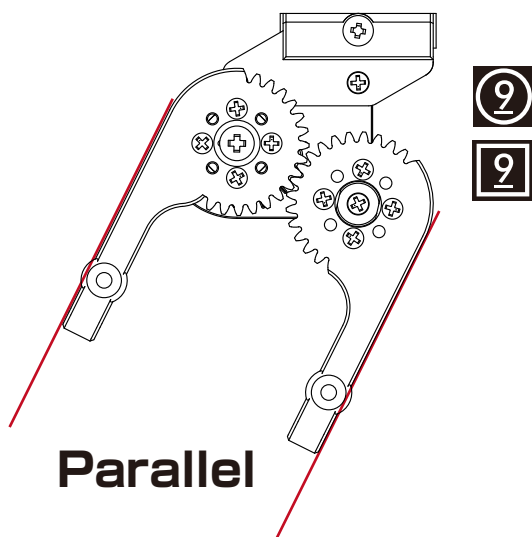



⑤-2. Attach the Gripper A-b to the Bottom shaft.

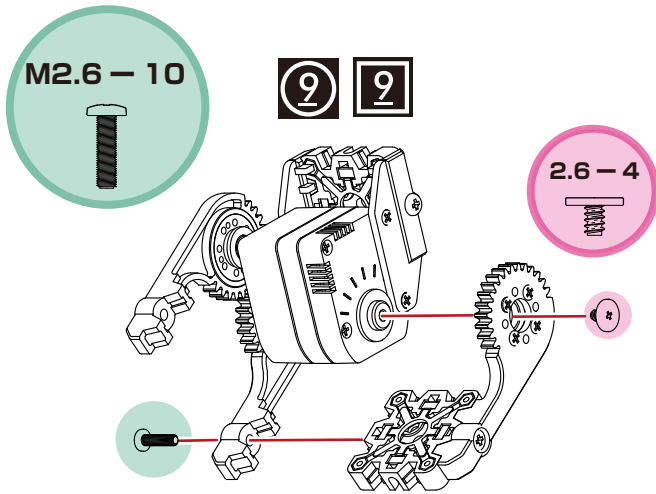

⑤-3. Detach the Case screw.

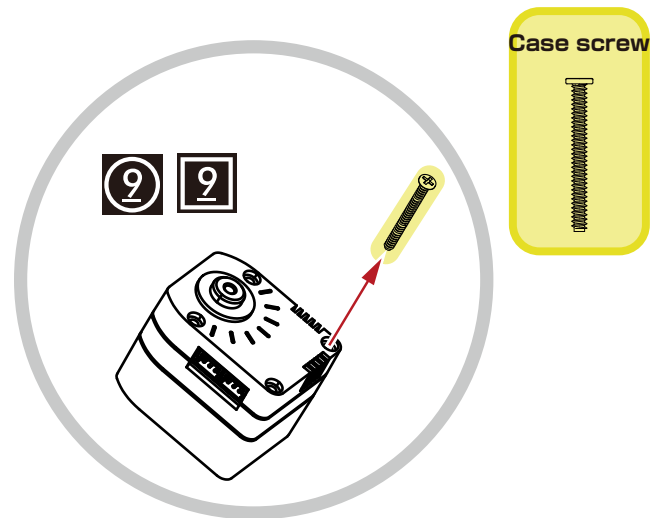

⑤-4. Attach the Free horn C.

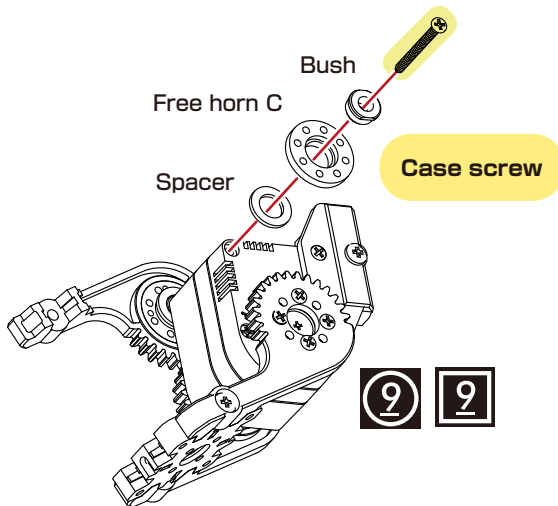

⑤-5. Attach the Gripper A-a to the Joint base A.

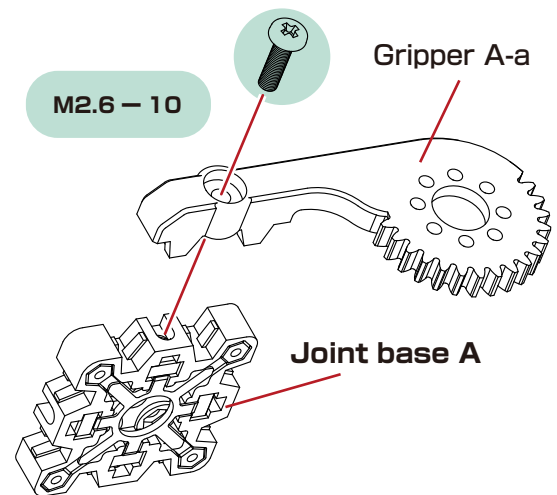

⑤-6. Attach the Gripper A-a.

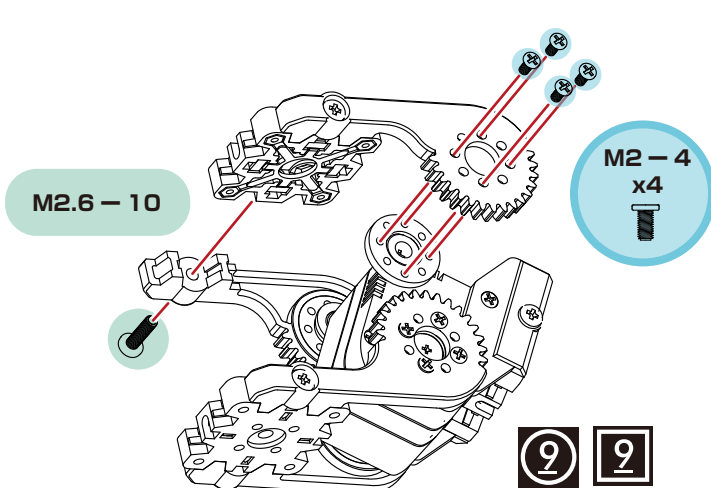

⑥ Attach the Joint base B.

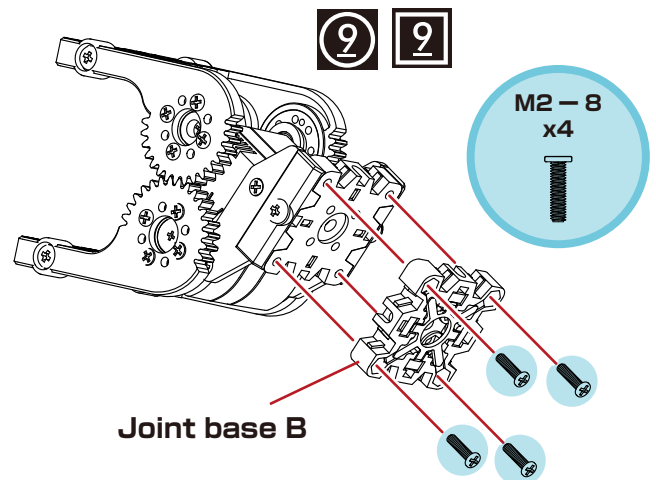

7

Joint frame 3300A

9 9

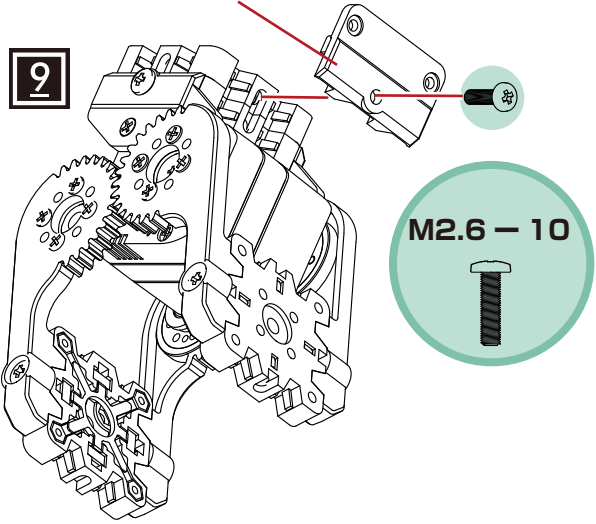

8

Joint frame 3300A

9 9

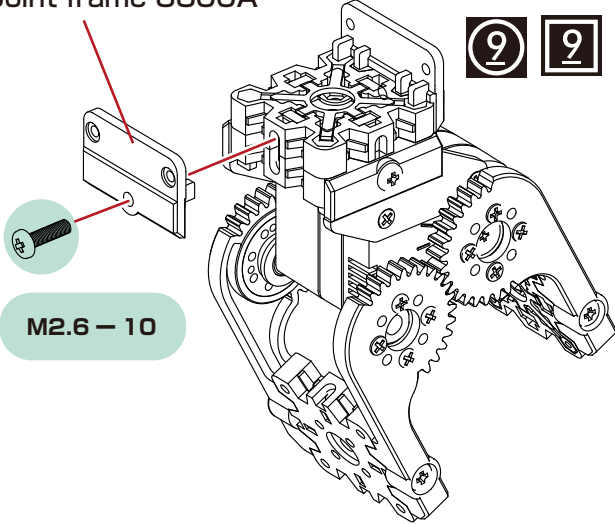

## Gripper

9

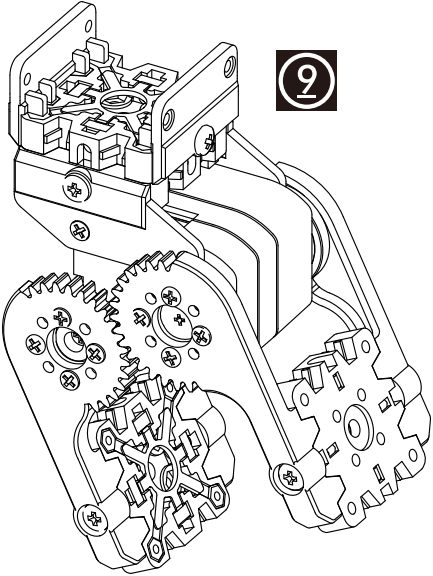

9

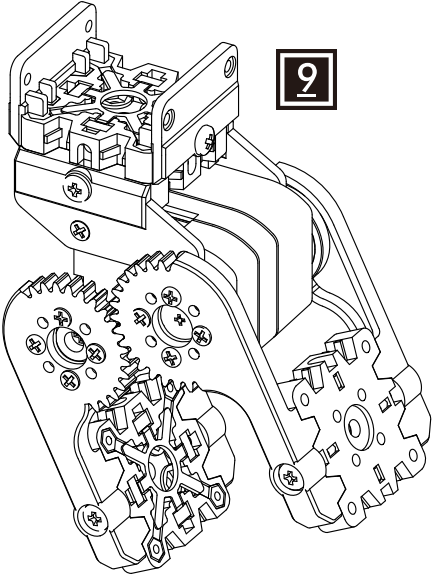

## Assemble the shoulder and elbow.

### Parts used

- Servo (ID 2, ID 3)
- Upper arm 3300-26 x2
- Bottom arm 3300-26 x1
- Cable guide X x1
- Joint Base + Frame A x1 (Assembled)
- M2-6 x3
- M2.6-10 x2
- 2.6-4 x1
- M3-6 x2
- ZH Connection cable 2 120mm x1



### Assemble part

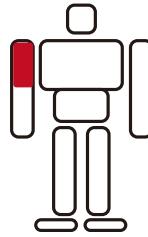

### Assembly parts completed

Right arm : Shoulder and elbow

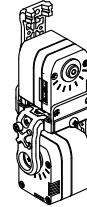

① Detach the case screw.

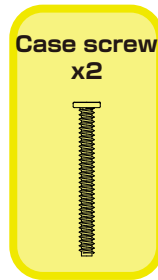
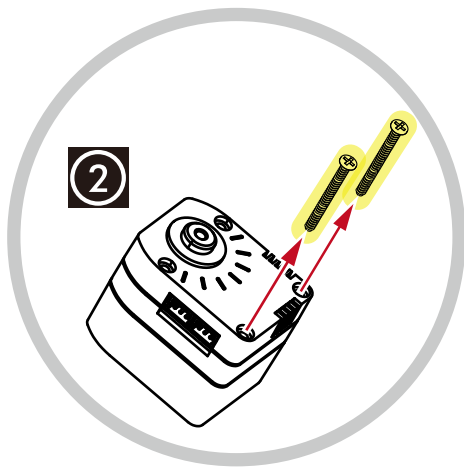

②

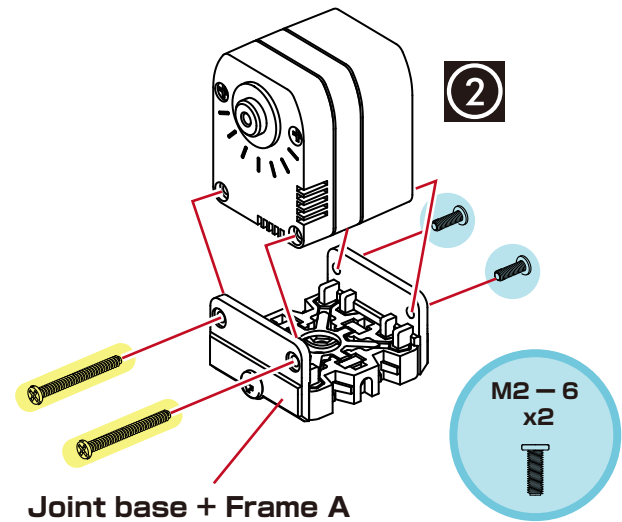

Joint base + Frame A

③

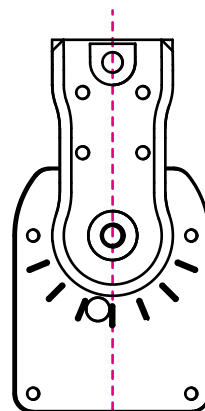
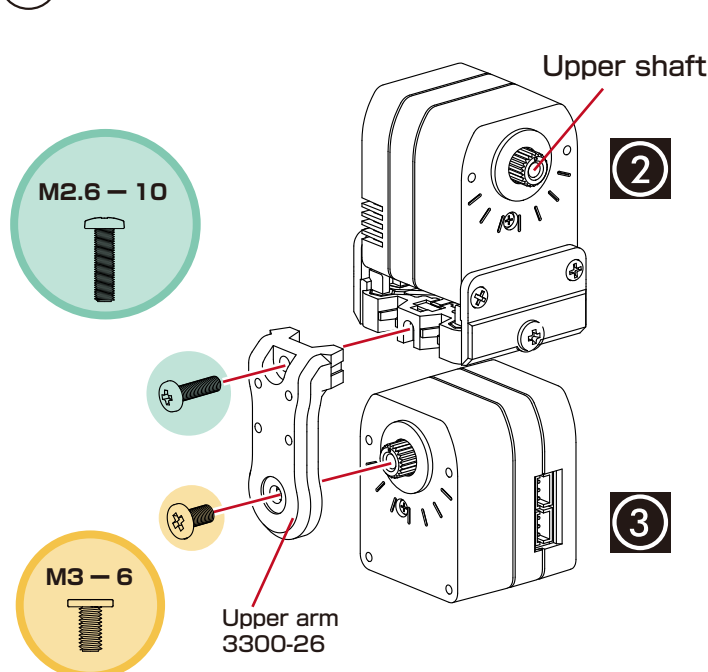

Upper arm 3300-38  
Installation Points

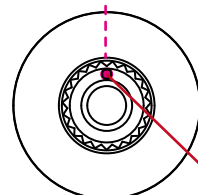

\* Confirm the servo origin and attach it straight.

4

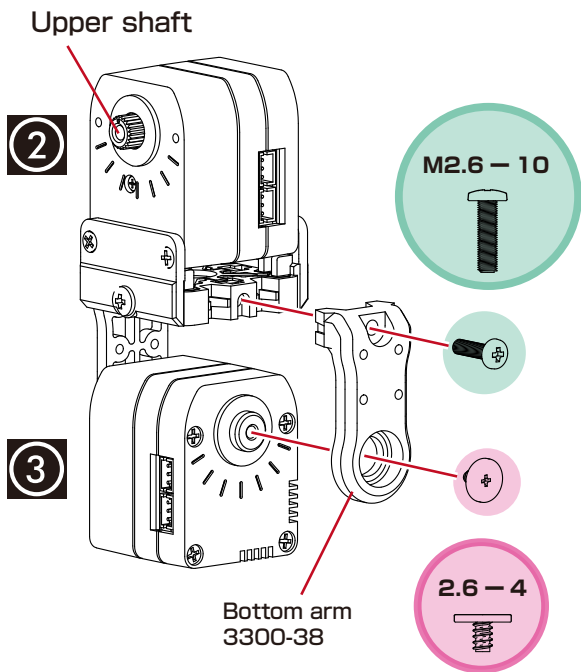

5

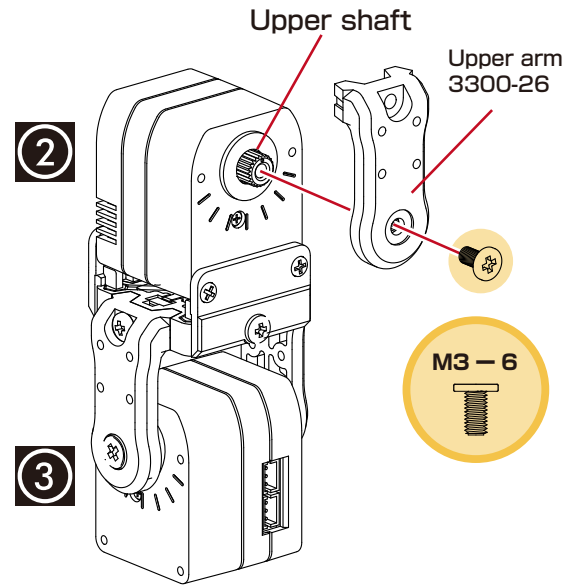

6

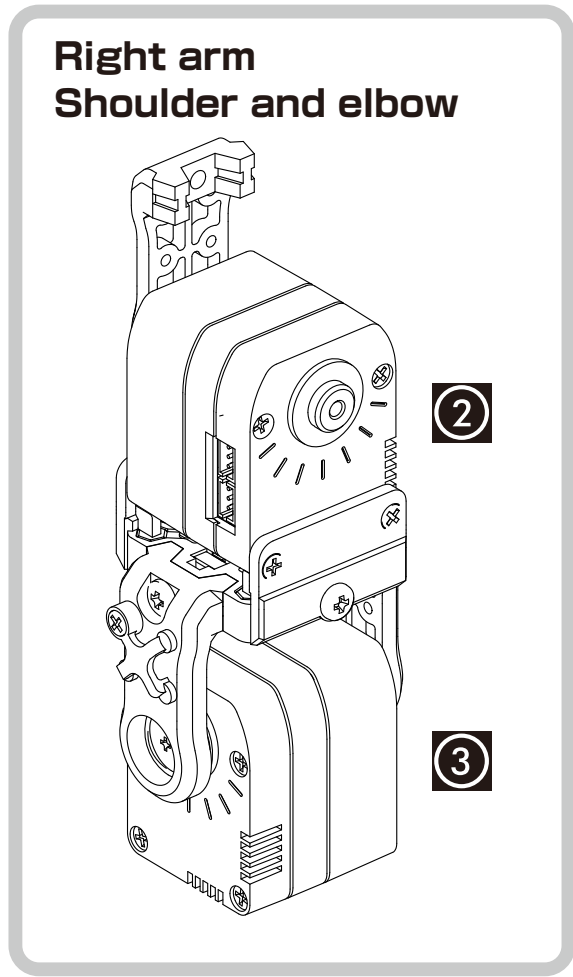
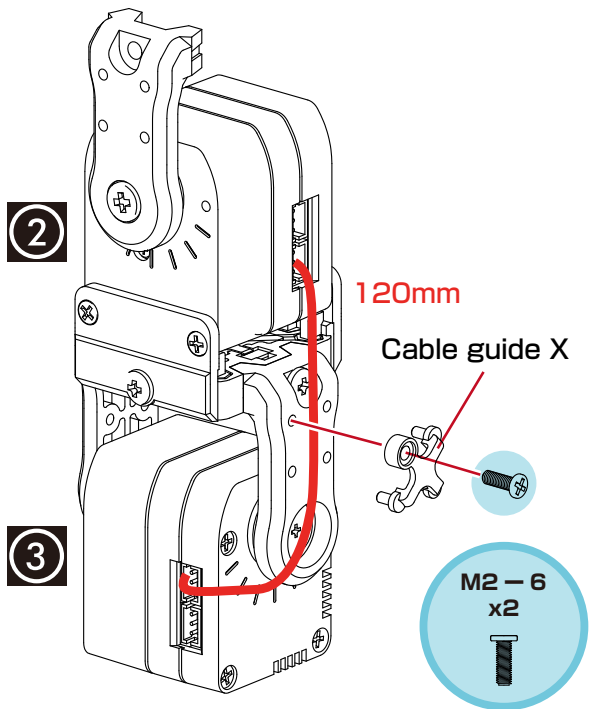

## ■ Attach the gripper.

### Parts used

- Gripper x1 (Assembled)
- M2-6 x2
- ZH Connection Cable 2 60mm x1

### Assemble part

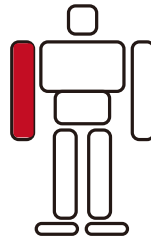

### Assembly parts completed

#### Right Arm

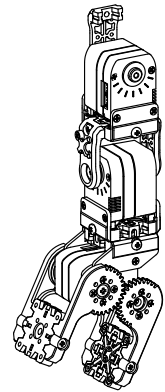

### 1 Detach the case screws.

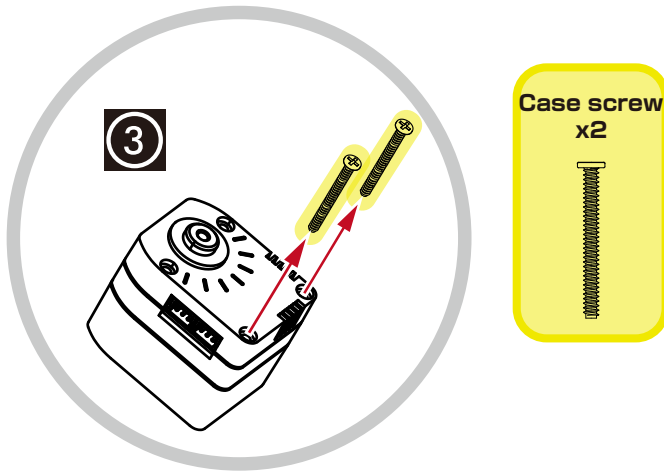

### 2

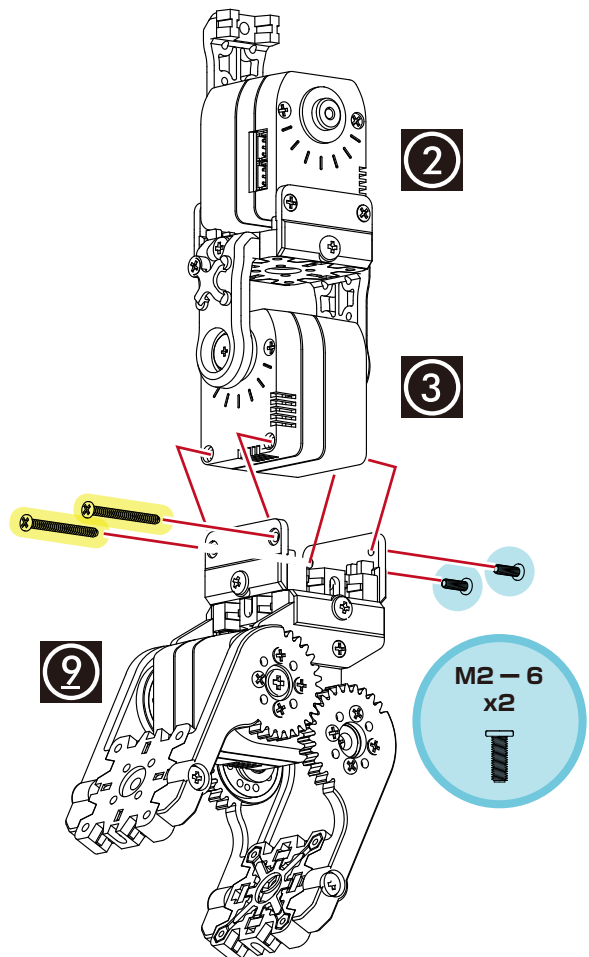

### 3

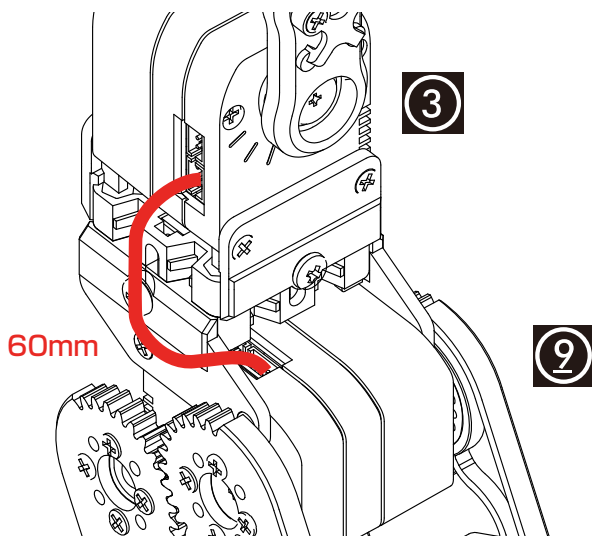

## Assemble the shoulder and elbow.

### Parts used

- Servo (ID 2, ID 3)
- Upper arm 3300-26 x2
- Bottom arm 3300-26 x1
- Cable guide X x1
- Joint Base + Frame A x1 (Assembled)
- M2-6 x3
- M2.6-10 x2
- 2.6-4 x1
- M3-6 x2
- ZH Connection cable 2 120mm x1



### Assemble part

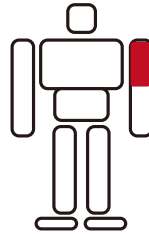

### Assembly parts completed

Left arm : Shoulder and elbow

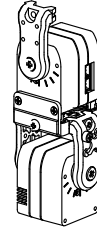

1 Detach the case screw.

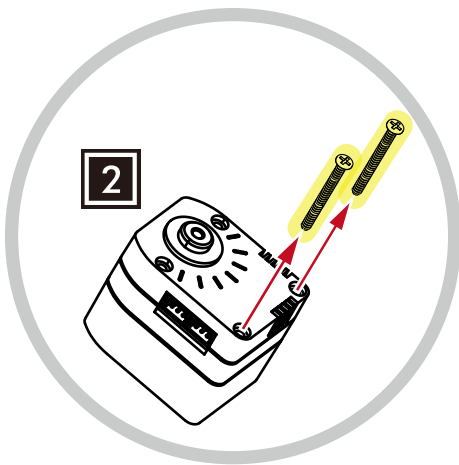

2

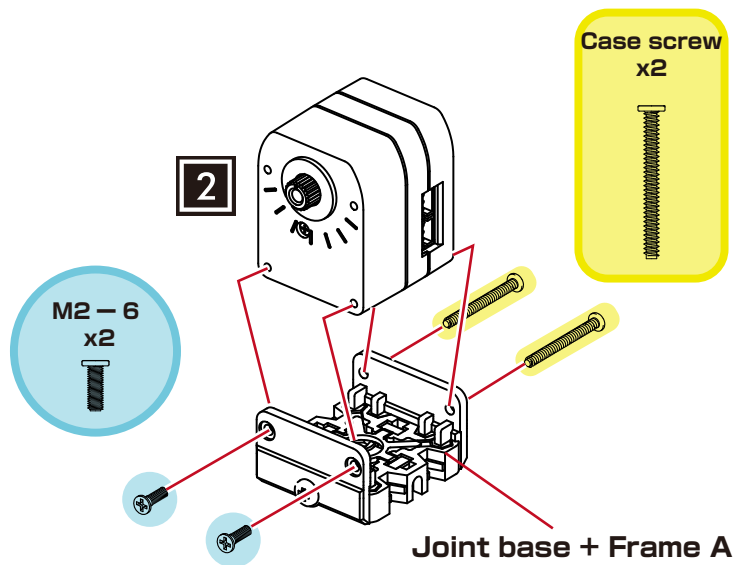

3

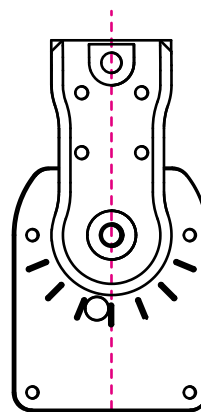
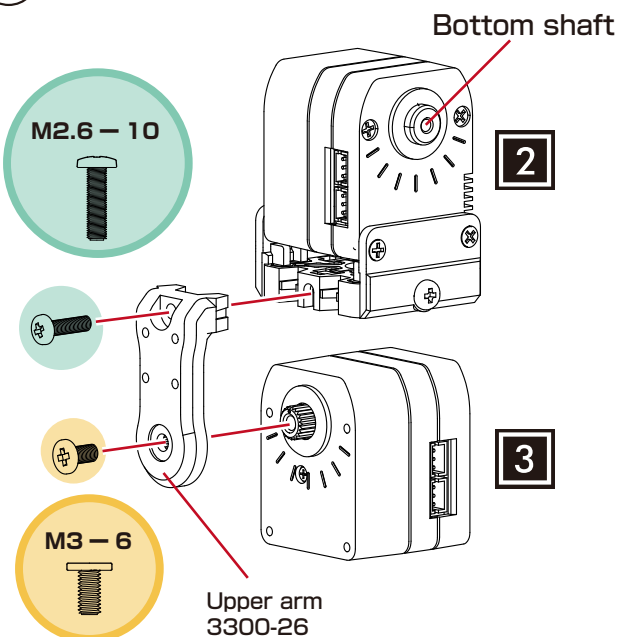

Upper arm 3300-38  
Installation Points

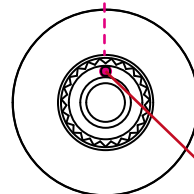

\* Confirm the servo origin and attach it straight.



4

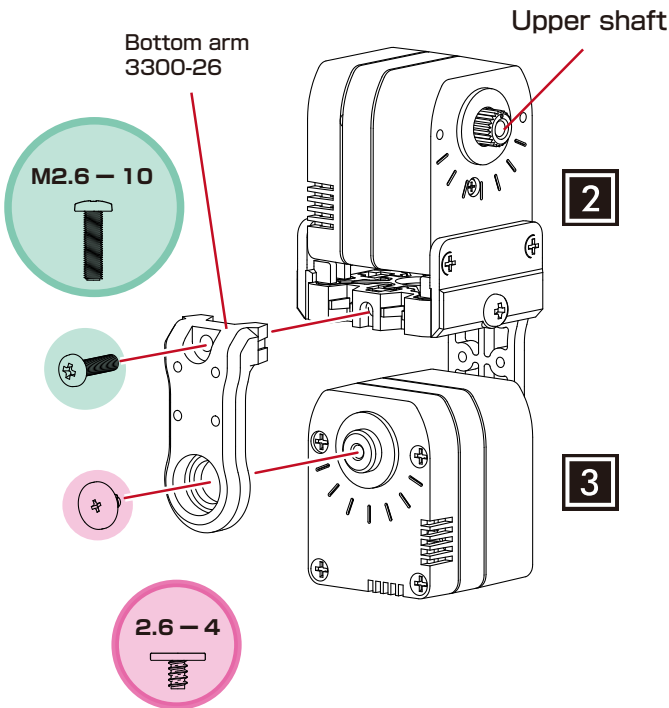

5

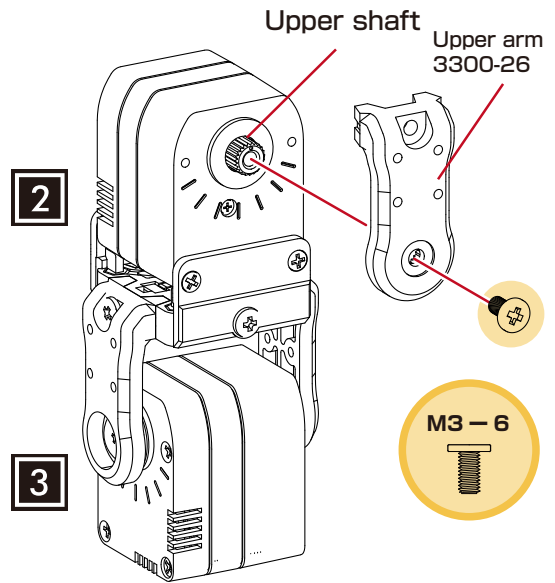

6

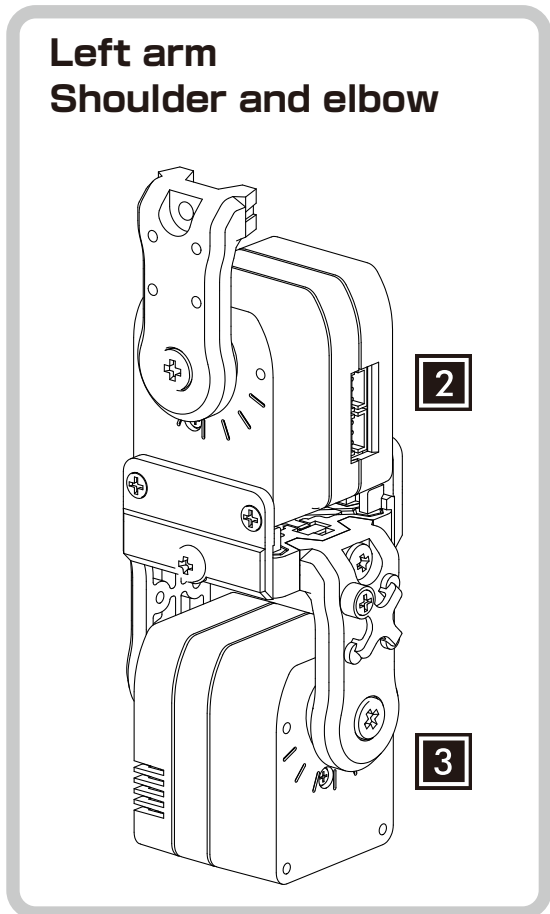
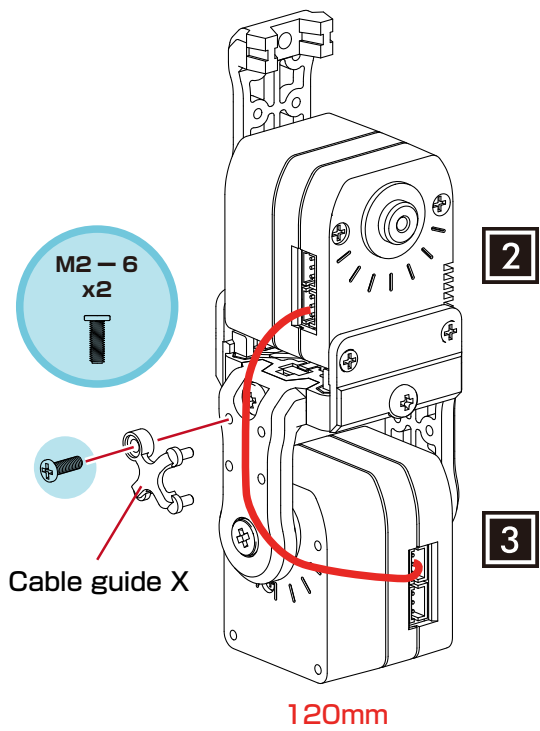

## ■ Attach the gripper.

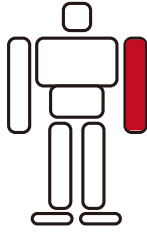
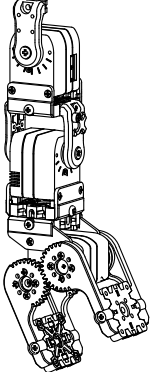
Parts used		Assemble part	Assembly parts completed
○ Gripper x1 (Assembled)	○ M2 - 6 x1		<b>Left Arm</b> 
	○ ZH Connection Cable 2 60mm x1		

① Detach the case screw.

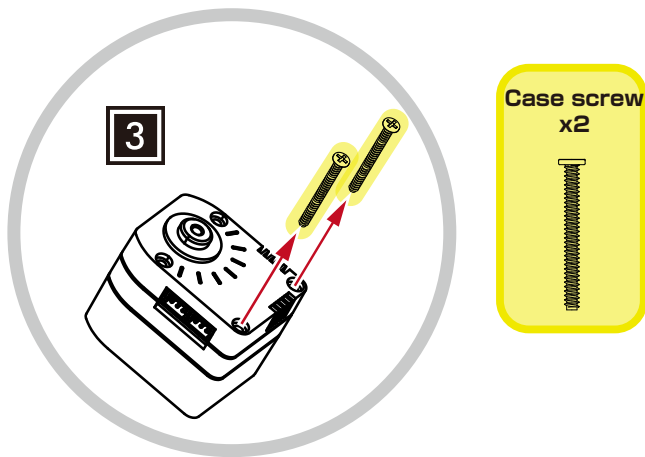

②

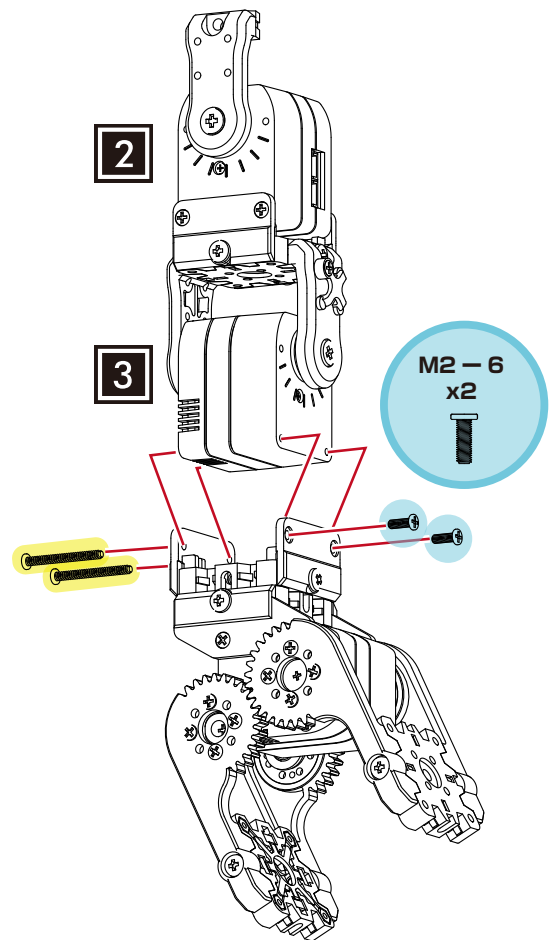

③

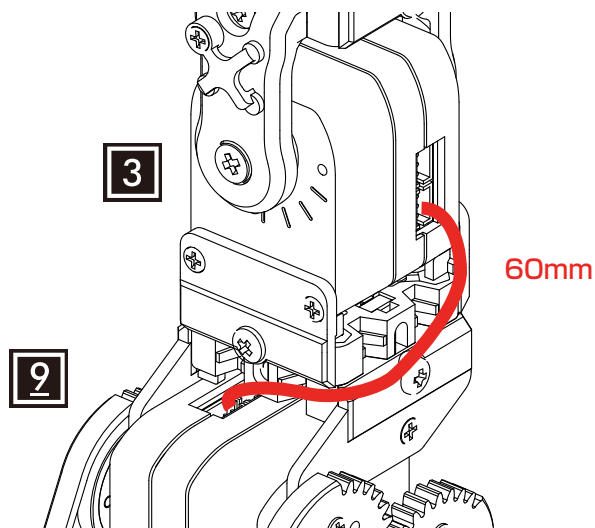

## Right leg: Assemble the hip joint cross frame.

### Parts used

- Servo (ID4, ID5)
- Cross upper frame x1
- Cross bottom frame x1
- Cross upper arm-28 x1
- Upper arm 3300-38 x1
- Bottom arm 3300-38 x1
- Double joint base x1 (Assembled)
- M2.6 - 10 x2
- M2 - 6 x8
- M3 - 6 x2
- 2.6 - 4 x1
- ZH connection cable 2 60mm x1 160mm x1

### Assemble part

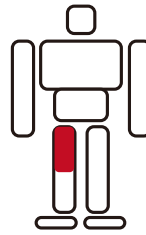

### Assembly parts completed

#### Right leg : Hip joint

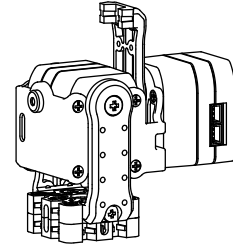

Always attach the cross upper frame after feeding the cable through. Make sure it is oriented so that the 160 mm cable comes out the outer side of the leg. Ensure that there is no twisting or pinching that would put excessive force on the cable.

① Wire the cable to the cross upper frame and attach to the servo.

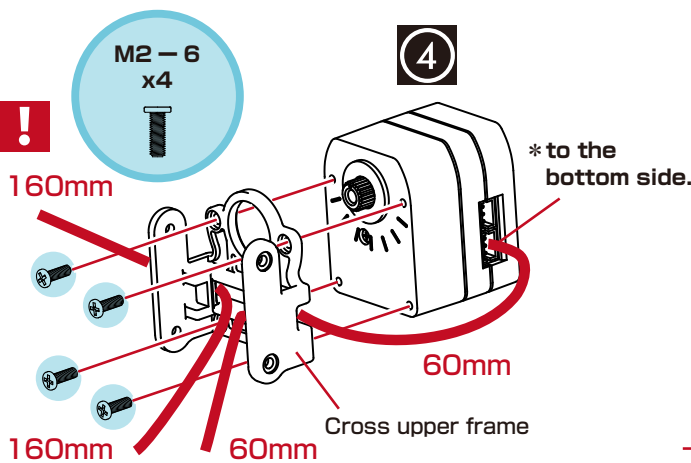

②

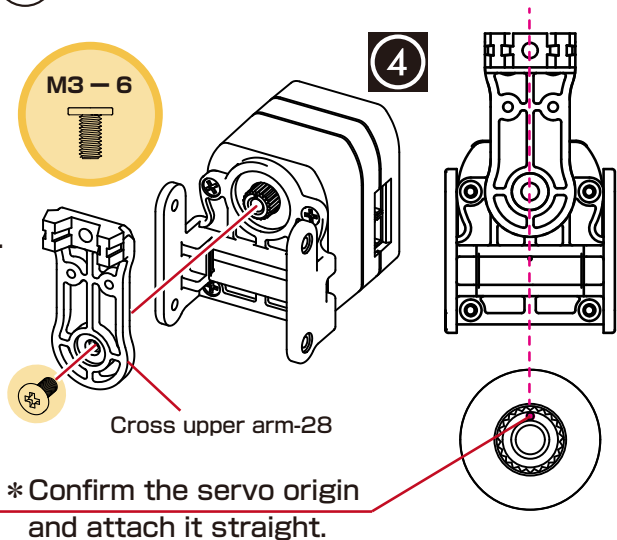

③

③-1. Detach case screws.

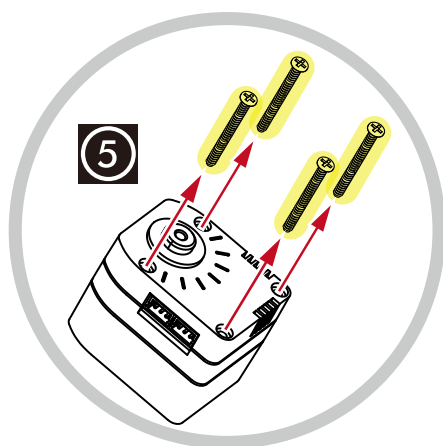

③-2. Attach as shown in the diagram.

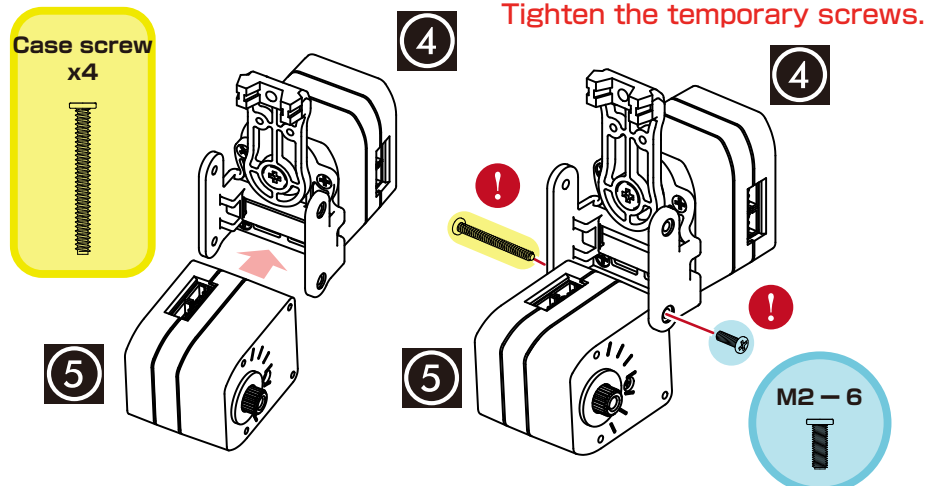

**!** Close the servo while pulling lightly on the cable (make sure the 60 mm cable is not too tight).  
 Whichever connector is used, it has no effect on operations, but be sure the cable is not overlapped or pinched.

③-3.

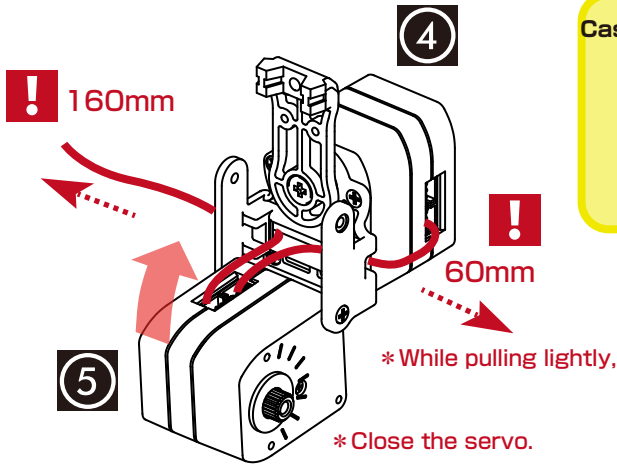

③-4.

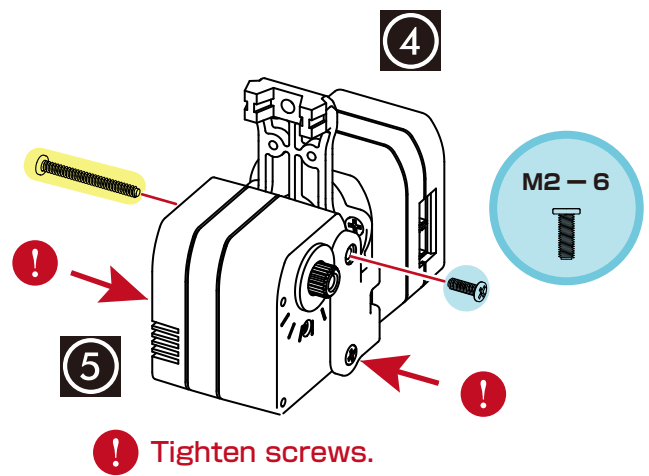

④

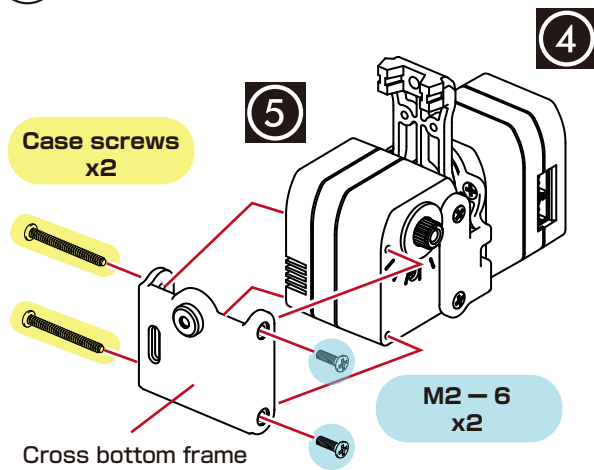

⑤

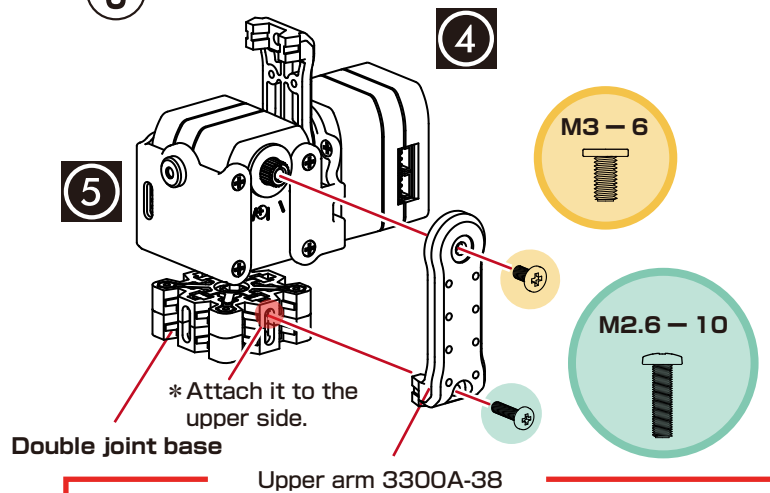

⑥

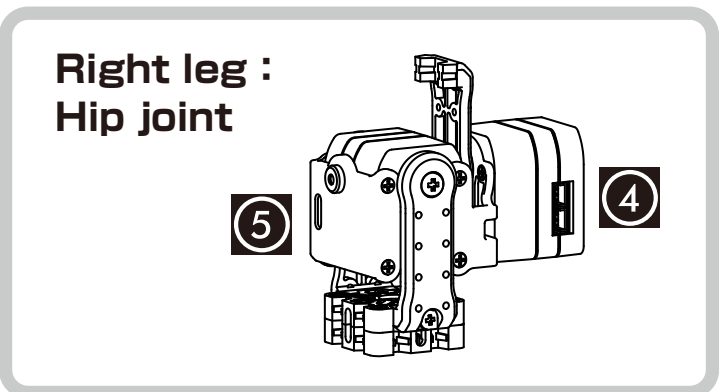
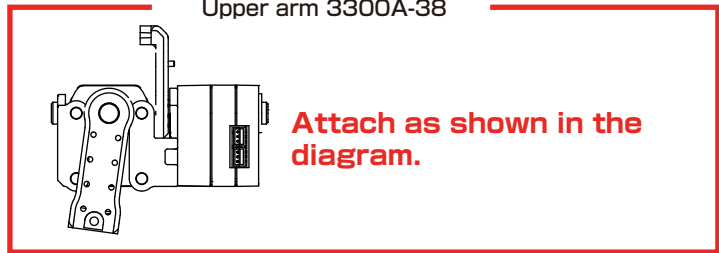
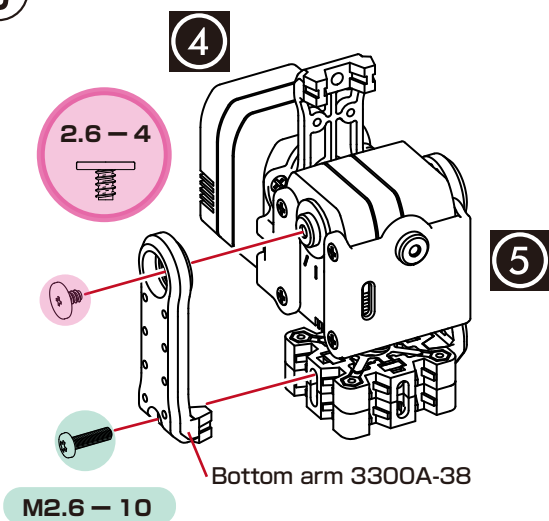

## Assemble the right ankle and right knee.

### Parts used

- Servo (ID6, ID7, ID8)
- Cross upper frame x1
- Cross bottom frame x1
- Cross upper arm-28 x1
- Upper arm 3300-38 x1
- Bottom arm 3300-38 x1
- Angle bracket -a x1
- Angle bracket -b x1
- M2.6 - 10 x2
- M2 - 6 x10
- M3 - 6 x2
- 2.6 - 4 x1
- M2.6 - 21 Nut x1
- ZH Connection cable 2 60mm x1
- ZH Connection cable 2 120mm x1



### Assemble part

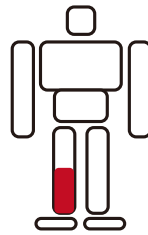

### Assembly parts completed

Right leg : Ankle and knee

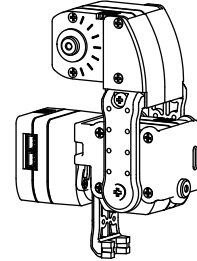

**!** Always attach the cross upper frame after feeding the cable through. Make sure it is oriented so that the 120 mm cable comes out the outer side of the leg. Ensure that there is no twisting or pinching that would put excessive force on the cable.

**1** Wire the cable to the cross upper frame and attach to the servo.

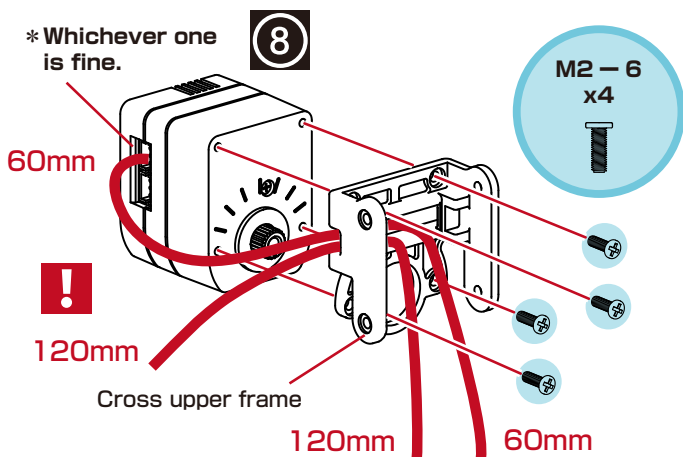

**2**

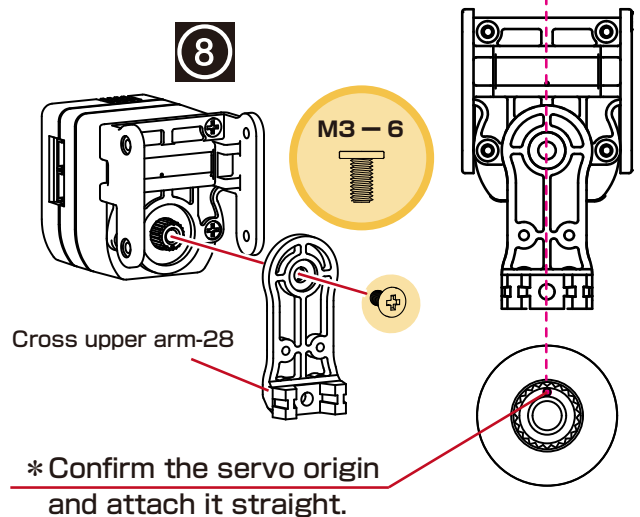

**3**

**3-1** Detach case screws.

**3-2** Attach as shown in the diagram.

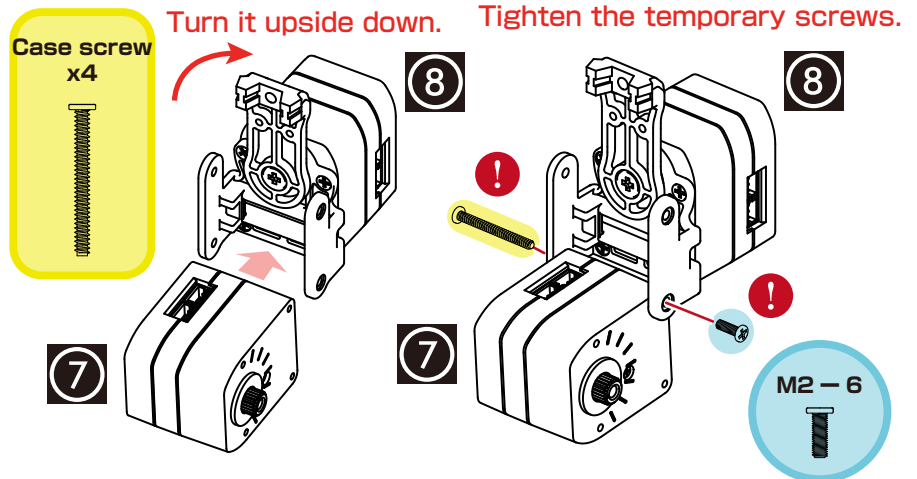
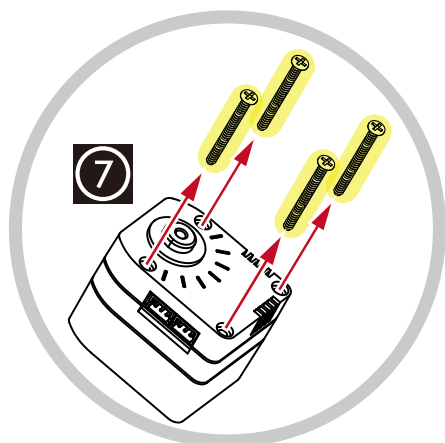

**!** Close the servo while pulling lightly on the cable (make sure the 60 mm cable is not too tight). Whichever connector is used, it has no effect on operations, but be sure the cable is not overlapped or pinched.

③-3.

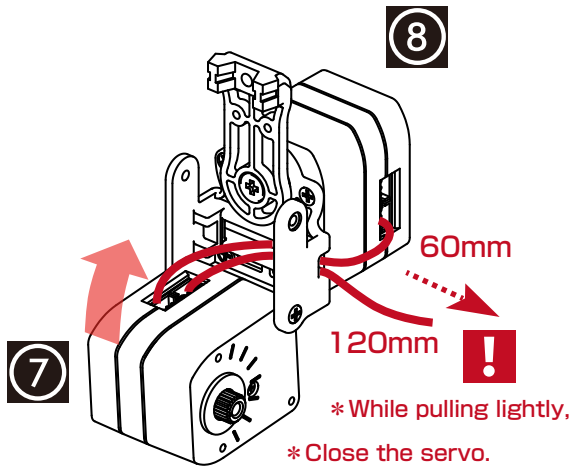

③-4.

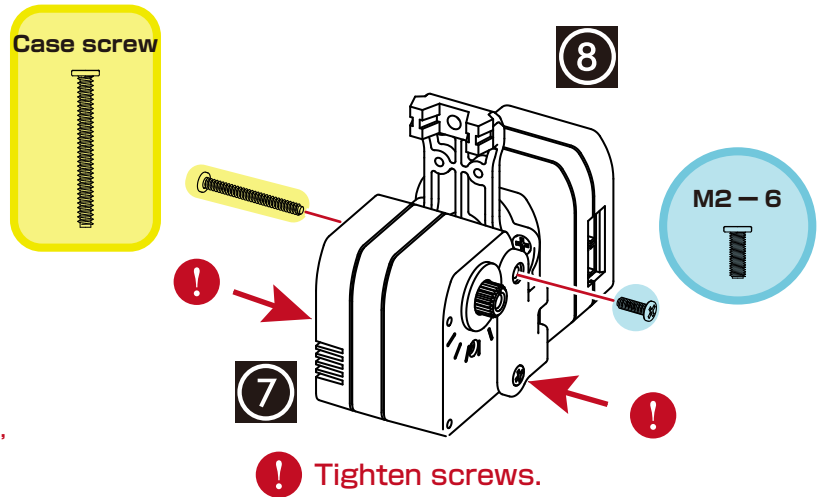

④

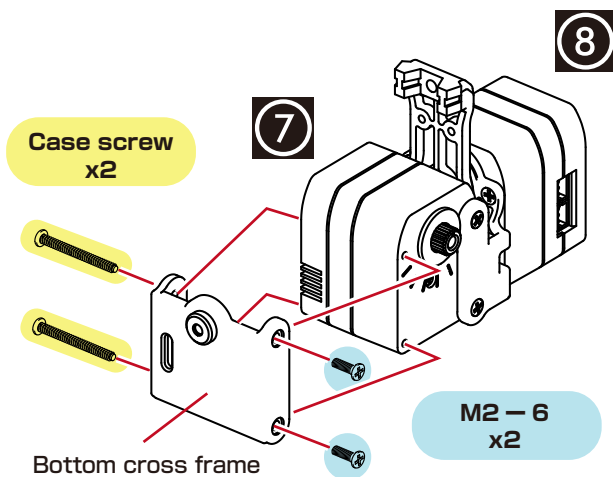

⑤

⑤-1.

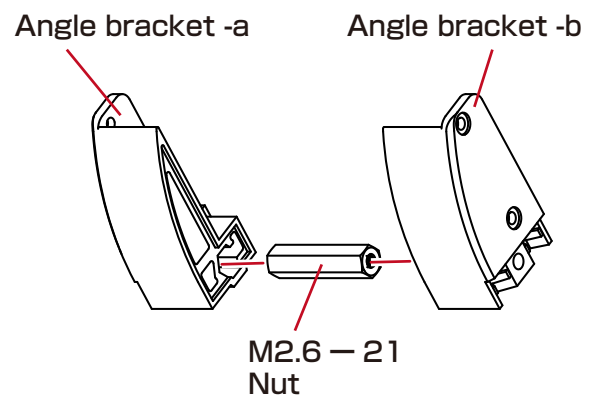

⑤-2. Detach case screws.

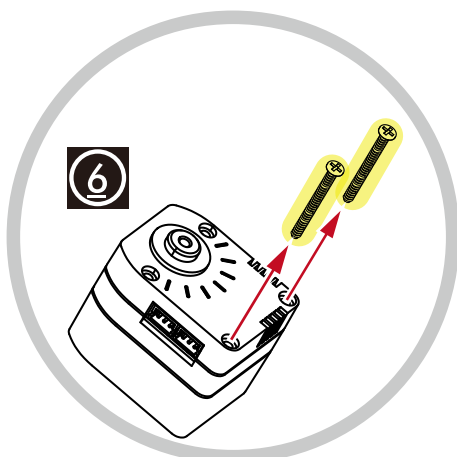

⑤-3.

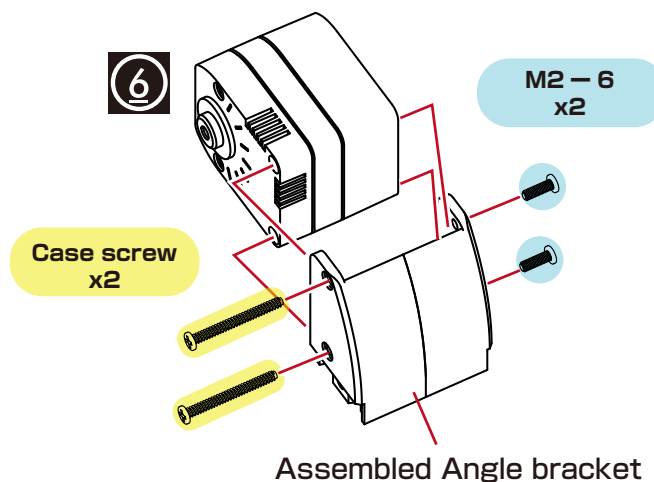



## ■ Assemble the right ankle and right knee.

6

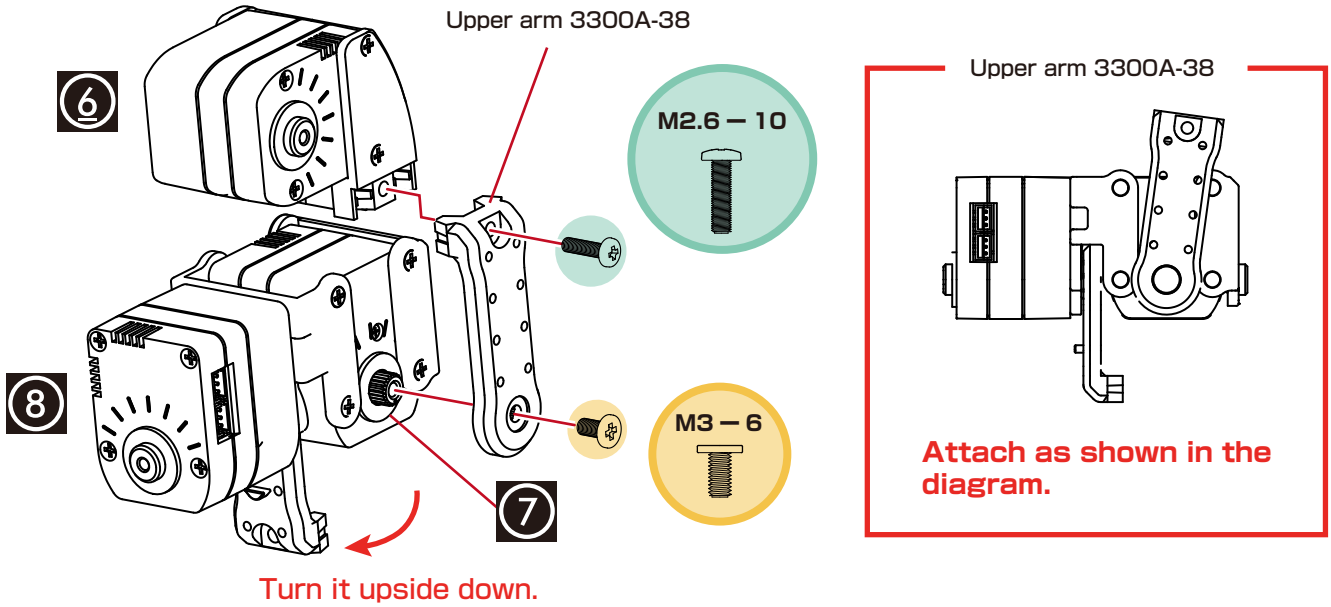

7

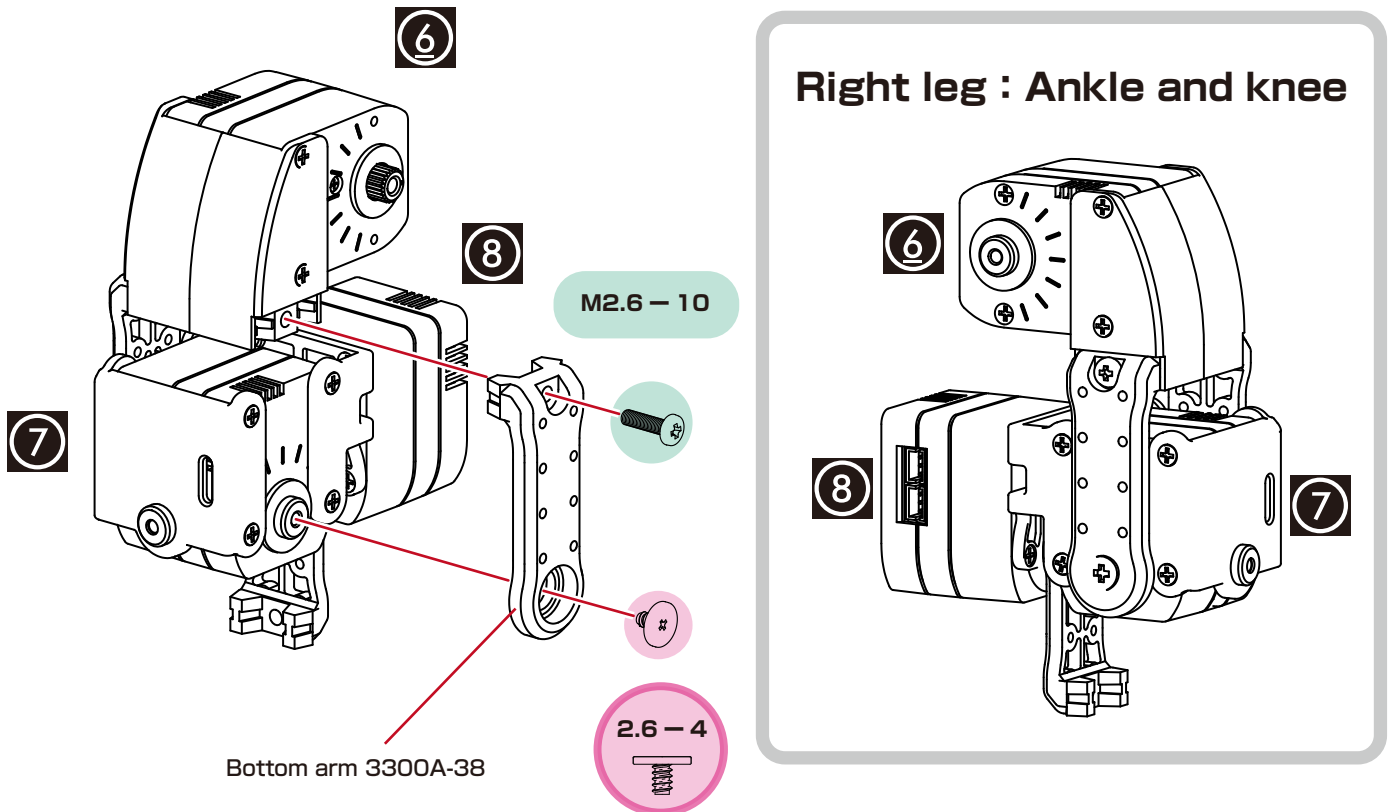

## Join the right leg.

### Parts used

- Upper arm 3300-20 x1
- Bottom arm 3300-20 x1
- Cross Bottom arm -28 x1
- Sole S03 x1
- Cable guide X x5
- Joint base A (Assembled) x1
- M2.6 - 10 x4
- M2 - 8 x4
- M2 - 6 x5
- M3 - 6 x1
- 2.6 - 4 x2

### Assemble part

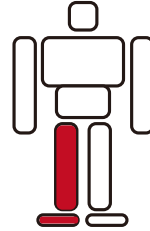

### Assembly parts completed

Right leg

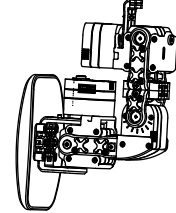

**A C H I**

1

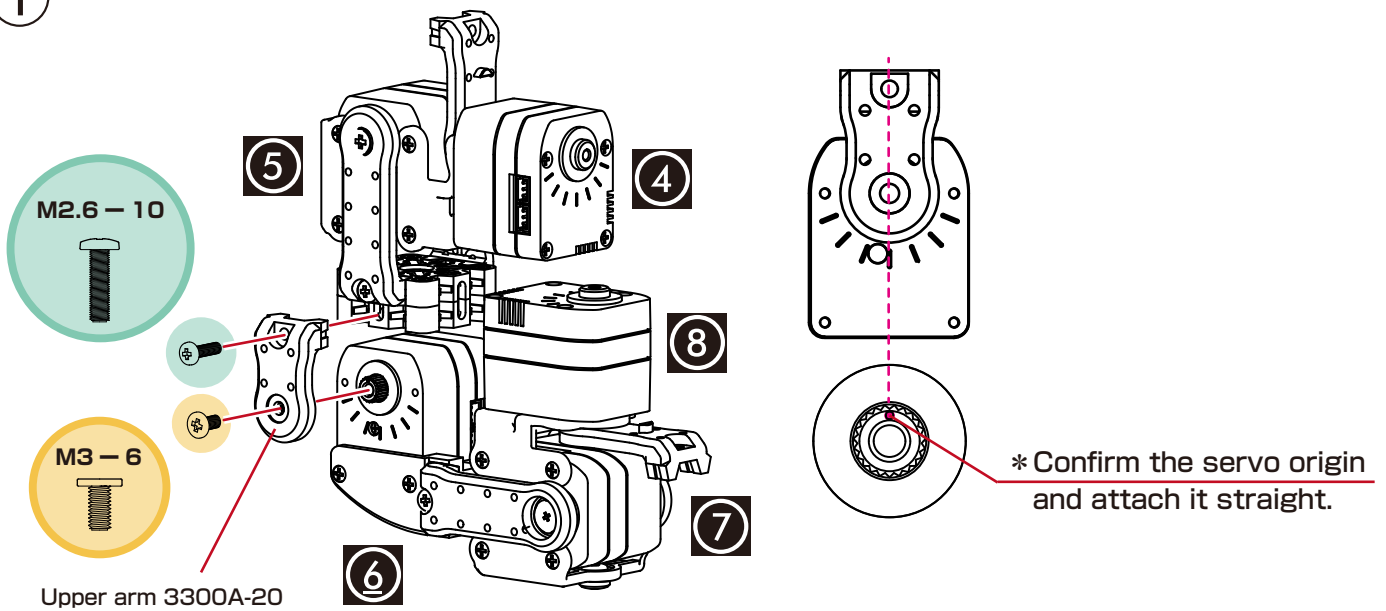

2

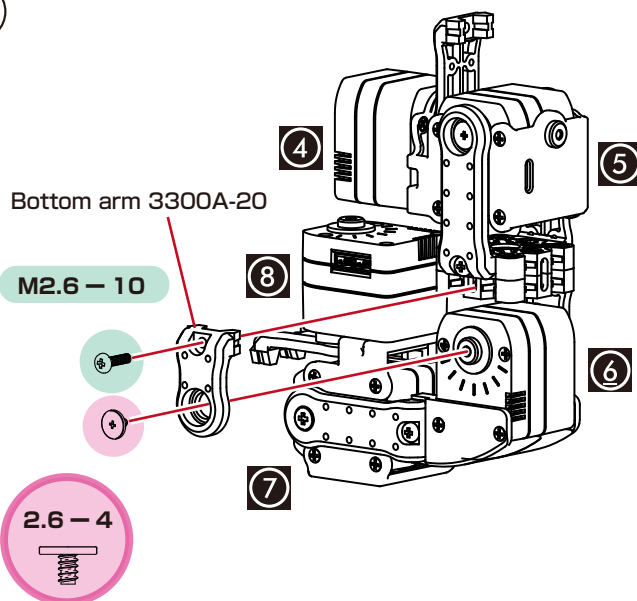

3

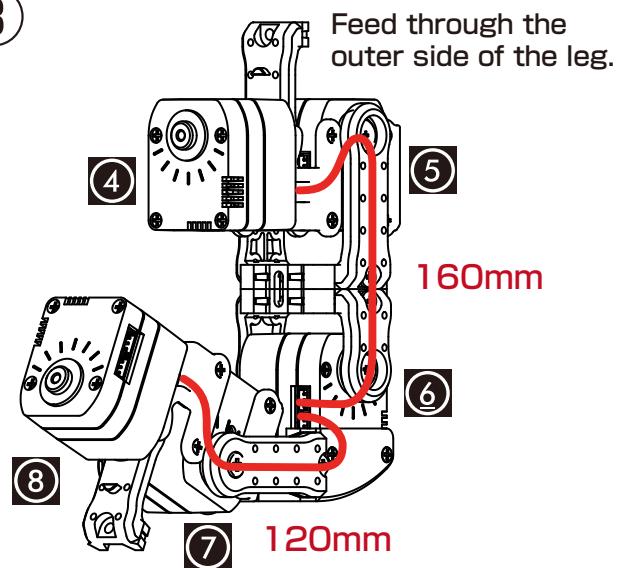

\* Make sure the cable does not twist or overlap. Connect 160 mm to the upper side connector and 120 mm to lower side connector.

## Assemble the sole and cable guide.

1

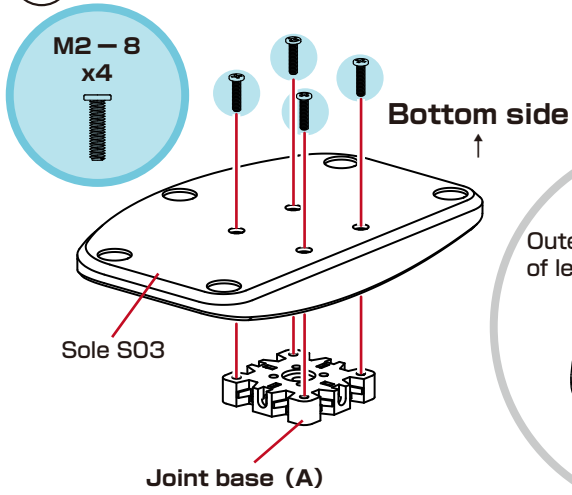

2

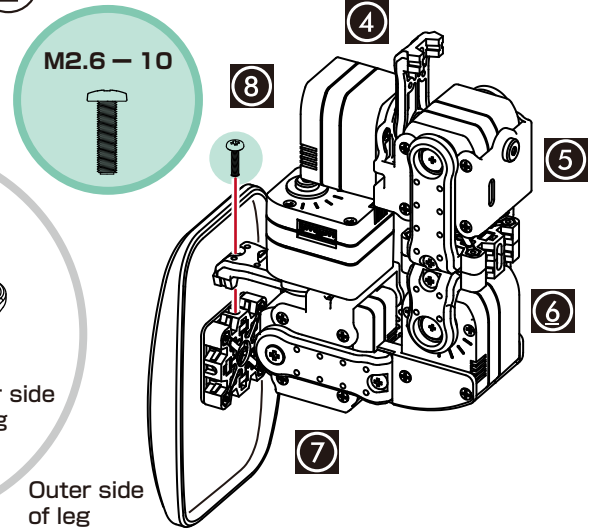

3

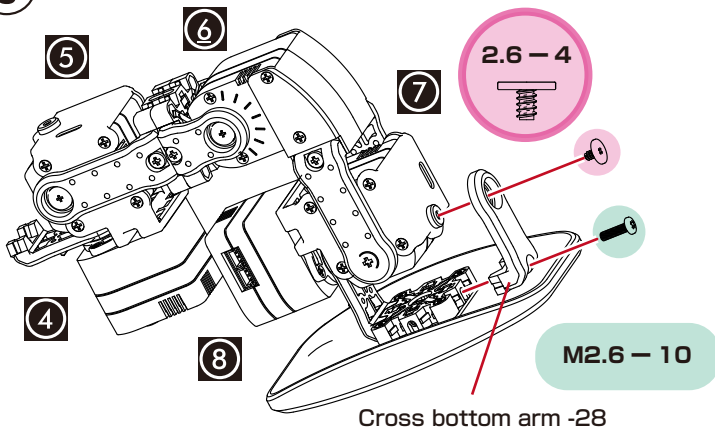

4

\*Move each joint and confirm that the cable is not stretched and that excessive force is not applied.

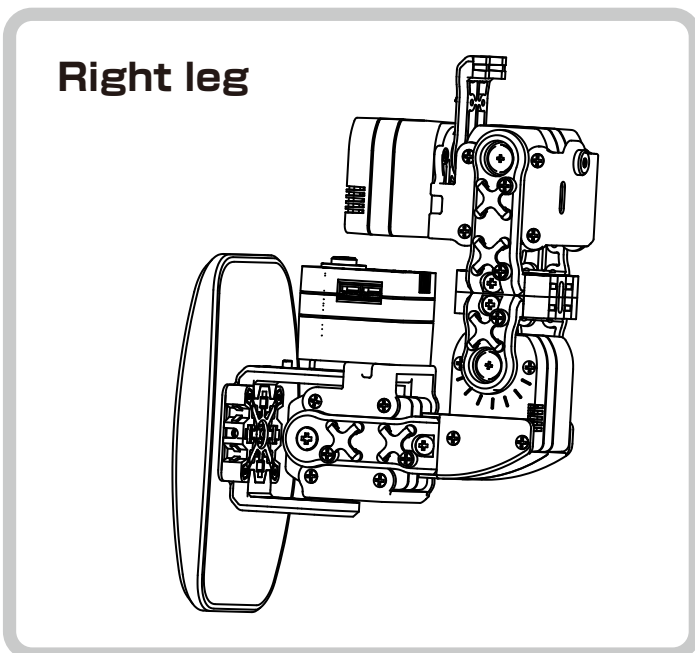
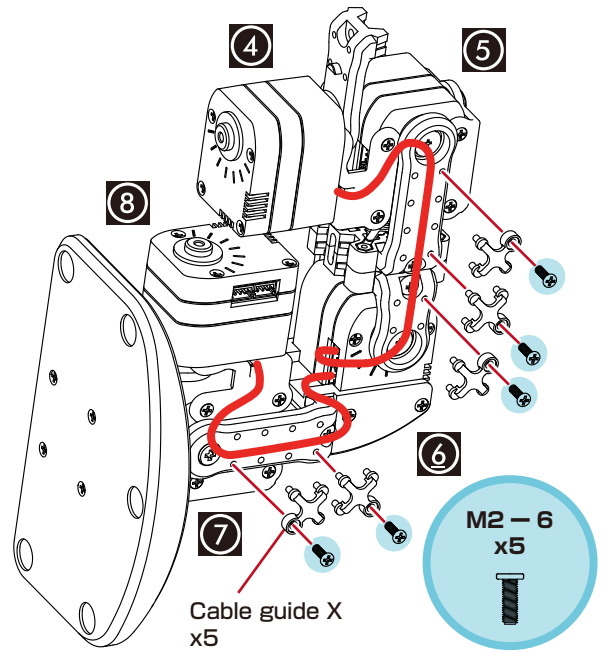

### Left leg: Assemble the hip joint cross frame.

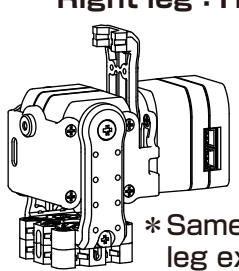
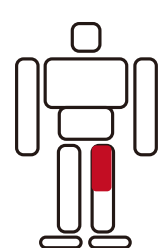
Parts used	Assemble part	Assembly parts completed
<ul style="list-style-type: none"> <li>○ Servo (ID4, ID5)</li> <li>○ Cross upper frame x1</li> <li>○ Cross bottom frame x1</li> <li>○ Cross upper arm-28 x1</li> <li>○ Upper arm 3300-38 x1</li> <li>○ bottom arm 3300-38 x1</li> <li>○ Double joint base x1 (Assembled)</li> </ul>	<ul style="list-style-type: none"> <li>○ M2.6 - 10 x2</li> <li>○ M2 - 6 x8</li> <li>○ M3 - 6 x2</li> <li>○ 2.6 - 4 x1</li> <li>○ ZH connection cable 2 60mm x1 160mm x1</li> </ul>	<p>Right leg : Hip joint</p>  <p>* Same as the right leg except for the wiring.</p>
<div style="display: flex; gap: 10px;"> <div style="border: 1px solid black; border-radius: 50%; width: 30px; height: 30px; display: flex; align-items: center; justify-content: center; background-color: #007bff; color: white; font-weight: bold;">C</div> <div style="border: 1px solid black; border-radius: 50%; width: 30px; height: 30px; display: flex; align-items: center; justify-content: center; background-color: #007bff; color: white; font-weight: bold;">H</div> <div style="border: 1px solid black; width: 30px; height: 30px; display: flex; align-items: center; justify-content: center; background-color: #333; color: white; font-weight: bold;">4</div> <div style="border: 1px solid black; width: 30px; height: 30px; display: flex; align-items: center; justify-content: center; background-color: #333; color: white; font-weight: bold;">5</div> </div>		

**!** Always attach the cross upper frame after feeding the cable through. Make sure it is oriented so that the 160 mm cable comes out the outer side of the leg. Ensure that there is no twisting or pinching that would put excessive force on the cable.

① Wire the cable to the cross upper frame and attach to the servo.

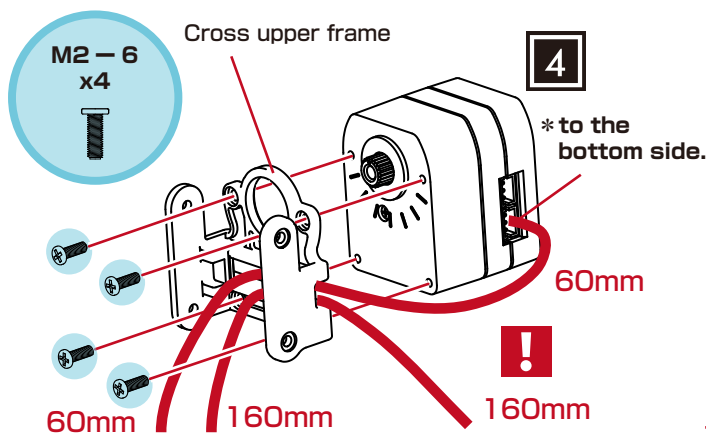

②

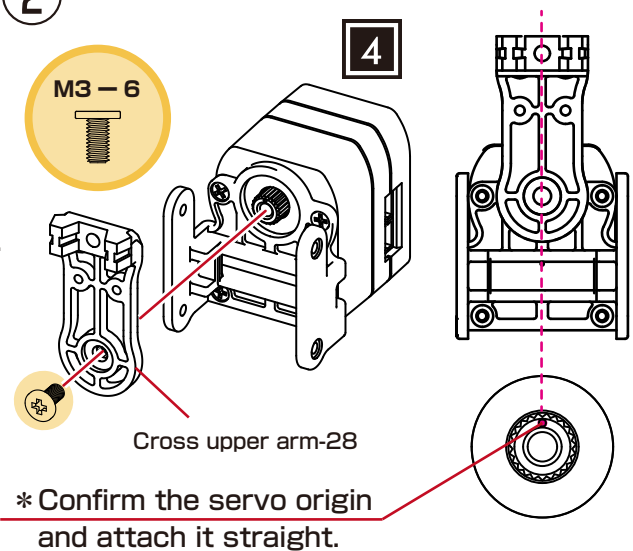

③

③-1. Detach case screws.

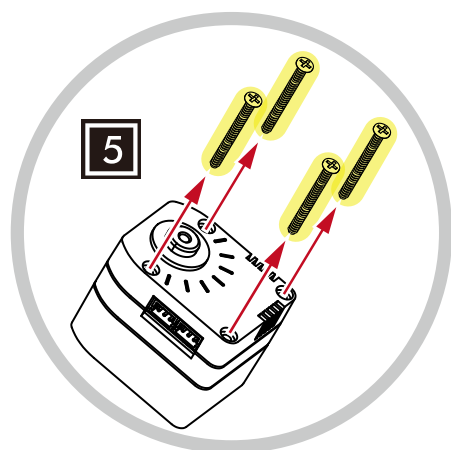

③-2. Attach as shown in the diagram.

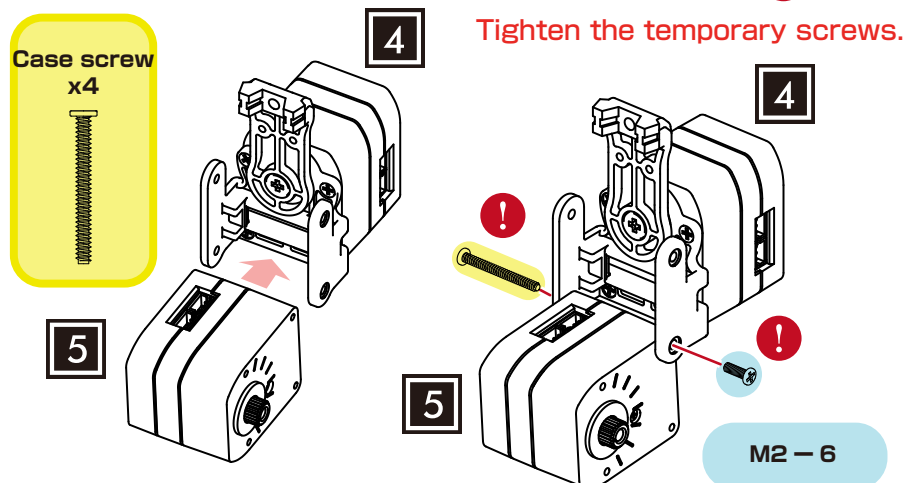

**!** Close the servo while pulling lightly on the cable (make sure the 60 mm cable is not too tight).  
Whichever connector is used, it has no effect on operations, but be sure the cable is not overlapped or pinched.

③-3.

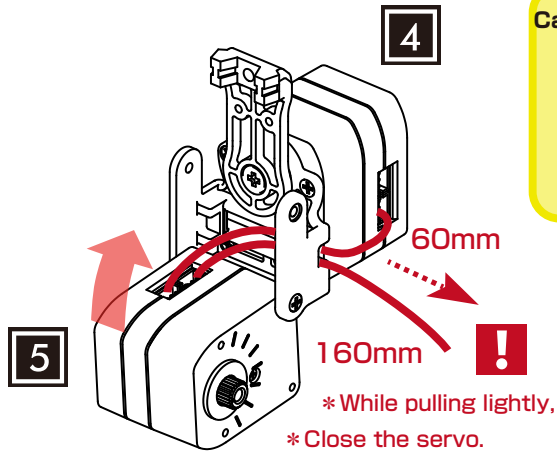

③-4.

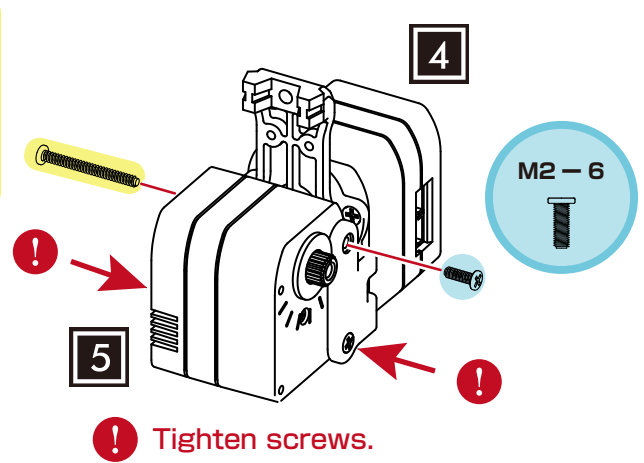

④

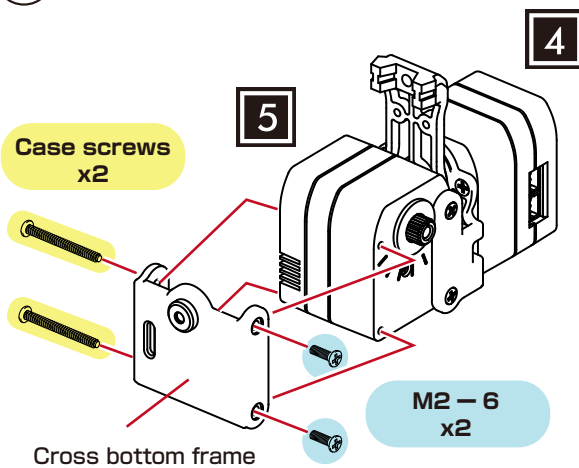

⑤

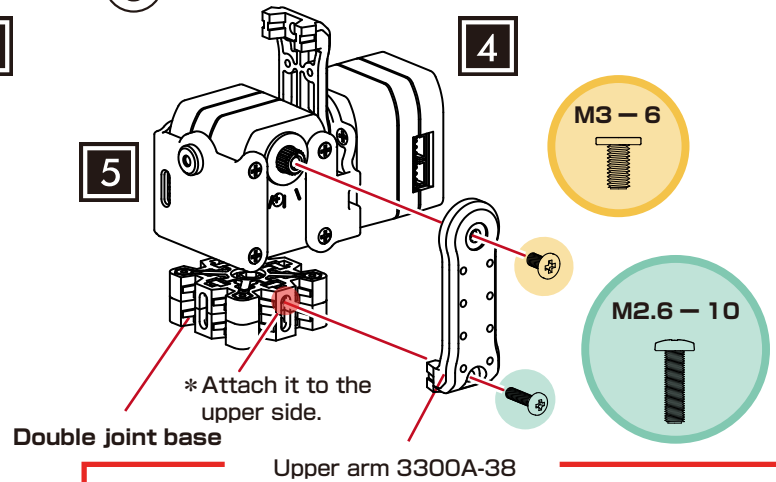

⑥

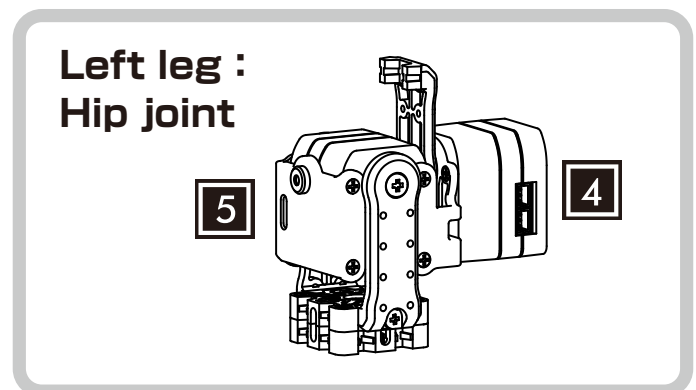
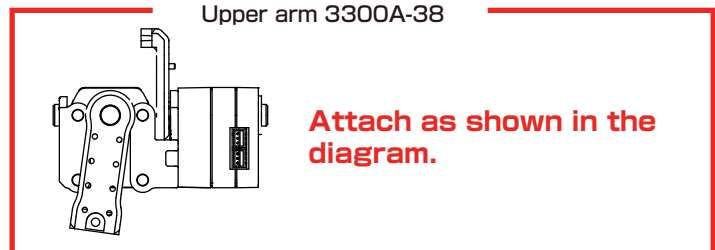
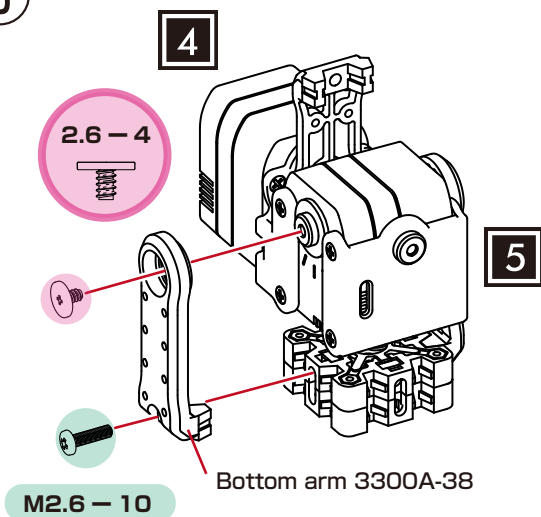



## Assemble the left ankle and left knee.

### Parts used

- Servo (ID6, ID7, ID8)
- Cross upper frame x1
- Cross bottom frame x1
- Cross upper arm-28 x1
- Upper arm 3300-38 x1
- Bottom arm 3300-38 x1
- Angle bracket -a x1
- Angle bracket -b x1
- M2.6 - 10 x2
- M2 - 6 x10
- M3 - 6 x2
- 2.6 - 4 x1
- M2.6 - 21 Nut x1
- ZH Connection cable 2 60mm x1
- ZH Connection cable 2 120mm x1

### Assemble part

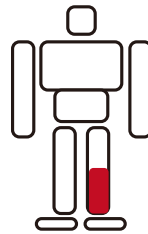

### Assembly parts completed

#### Left leg : Ankle and knee

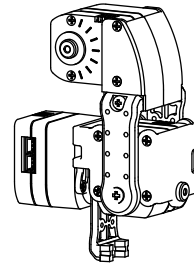

\* Same as the right leg except for the wiring.



**!** Always attach the cross upper frame after feeding the cable through. Make sure it is oriented so that the 120 mm cable comes out the outer side of the leg. Ensure that there is no twisting or pinching that would put excessive force on the cable.

**1** Wire the cable to the cross upper frame and attach to the servo.

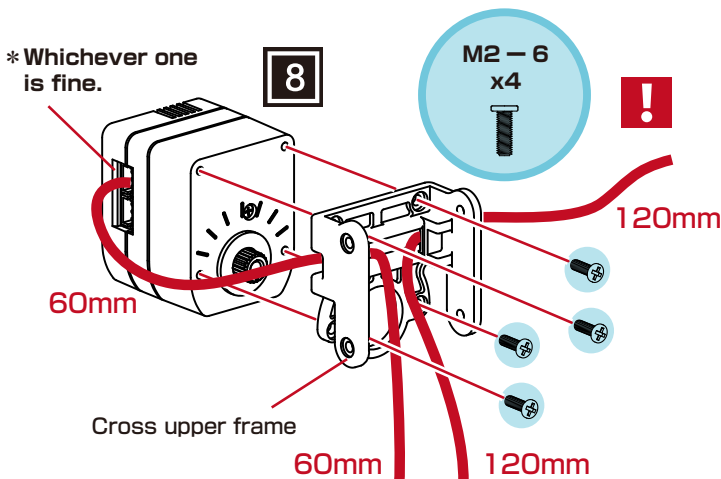

**2**

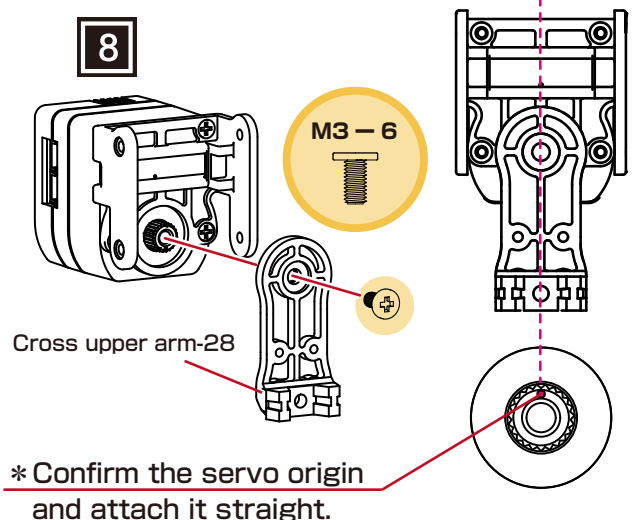

**3** **3-1**. Detach case screws.

**3-2**. Attach as shown in the diagram.

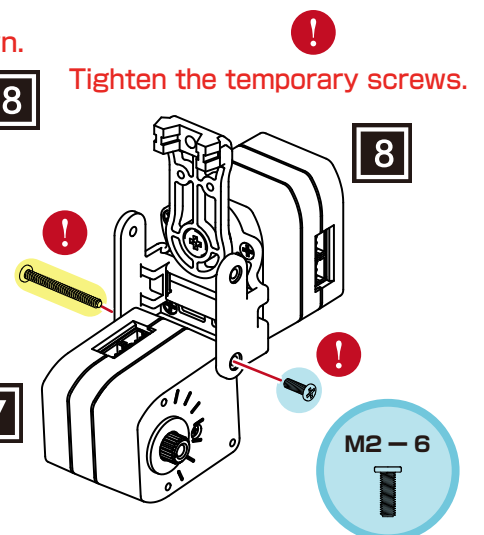
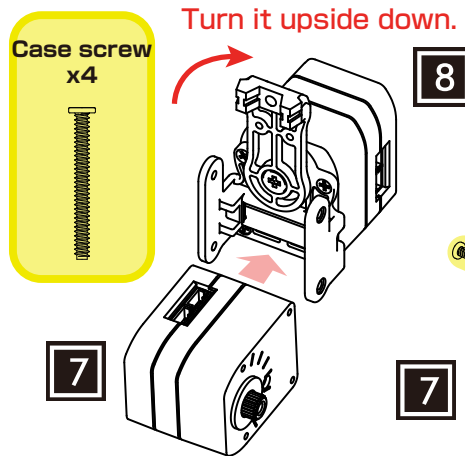
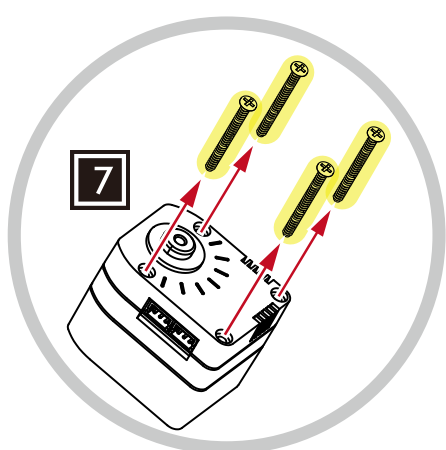



**!** Close the servo while pulling lightly on the cable (make sure the 60 mm cable is not too tight).  
 Whichever connector is used, it has no effect on operations, but be sure the cable is not overlapped or pinched.

③-3.

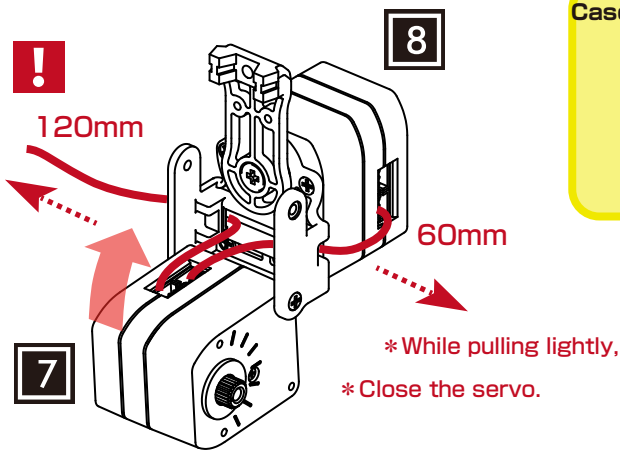

③-4.

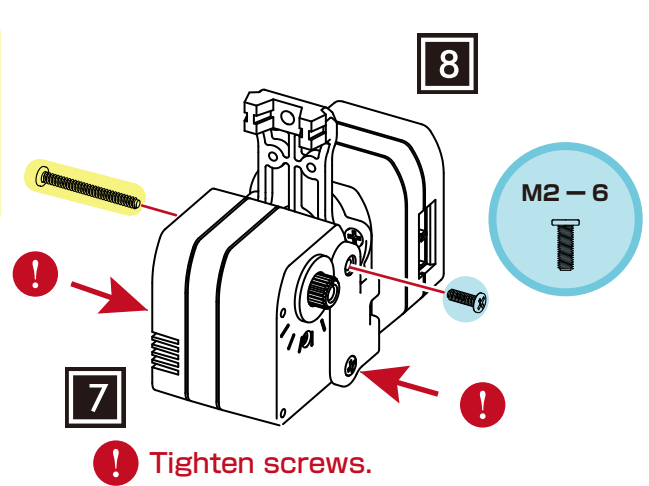

④

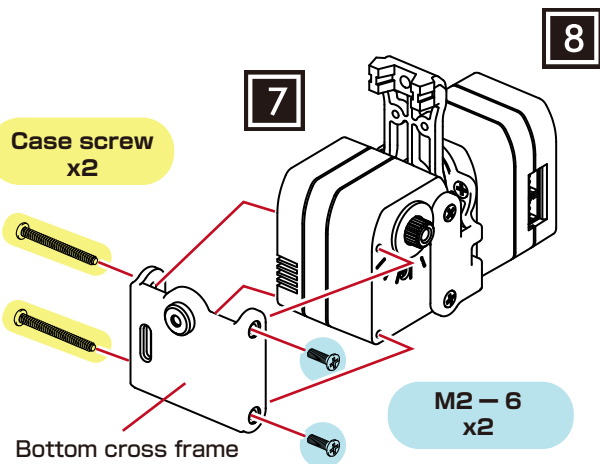

⑤

⑤-1.

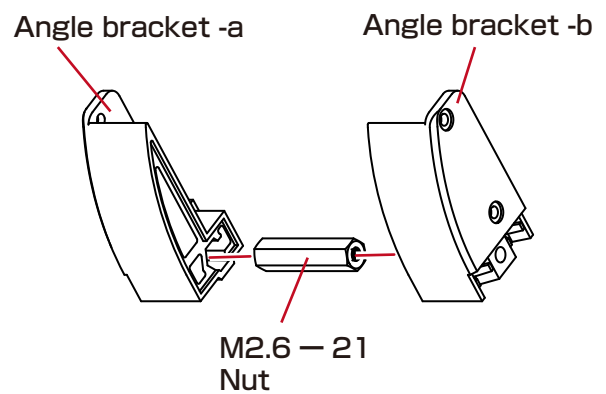

⑤-2. Detach case screws.

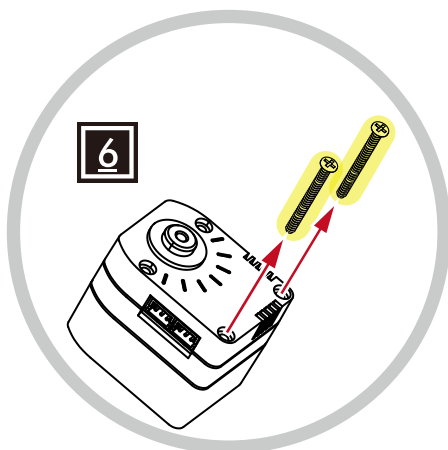

⑤-3.

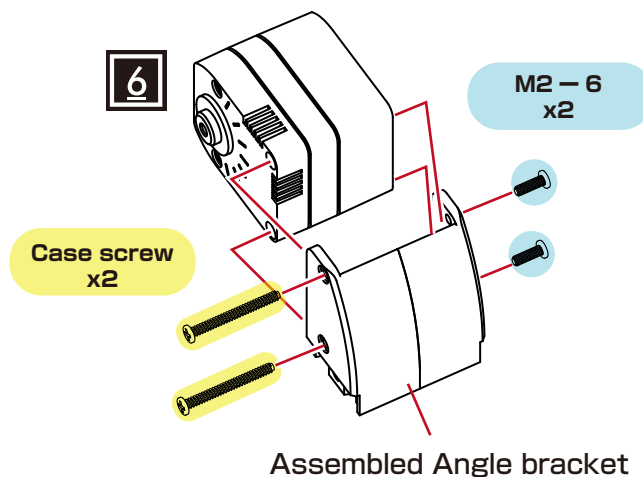

## ■ Assemble the left ankle and left knee.

6

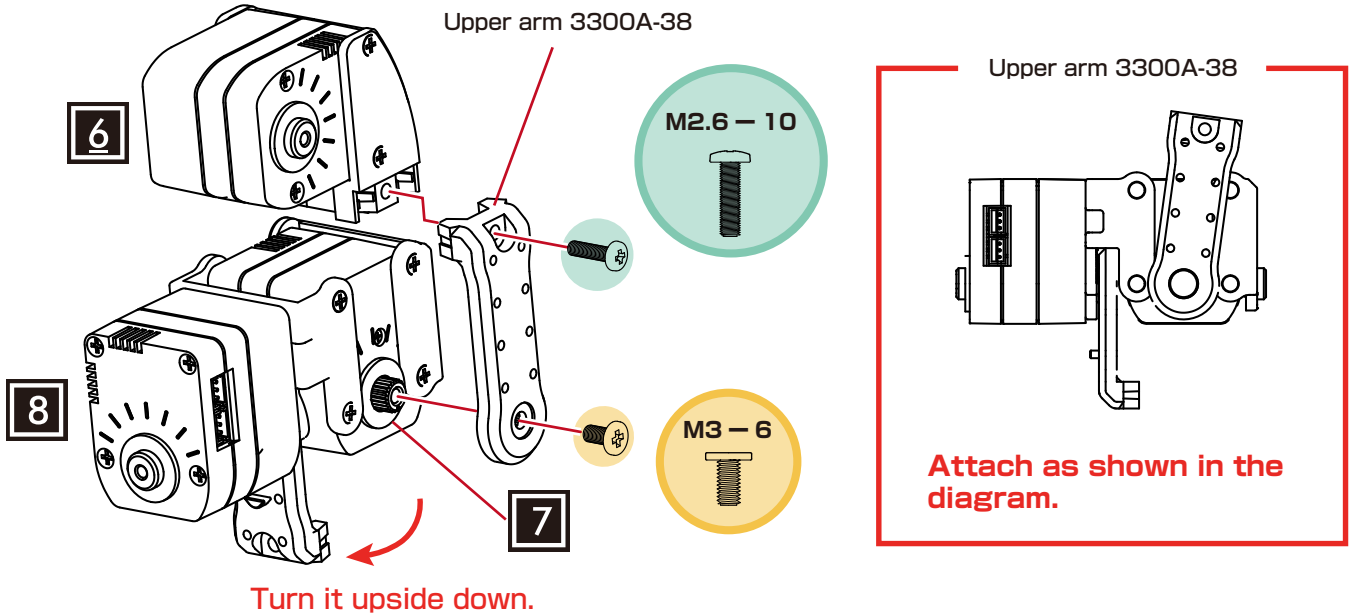

7

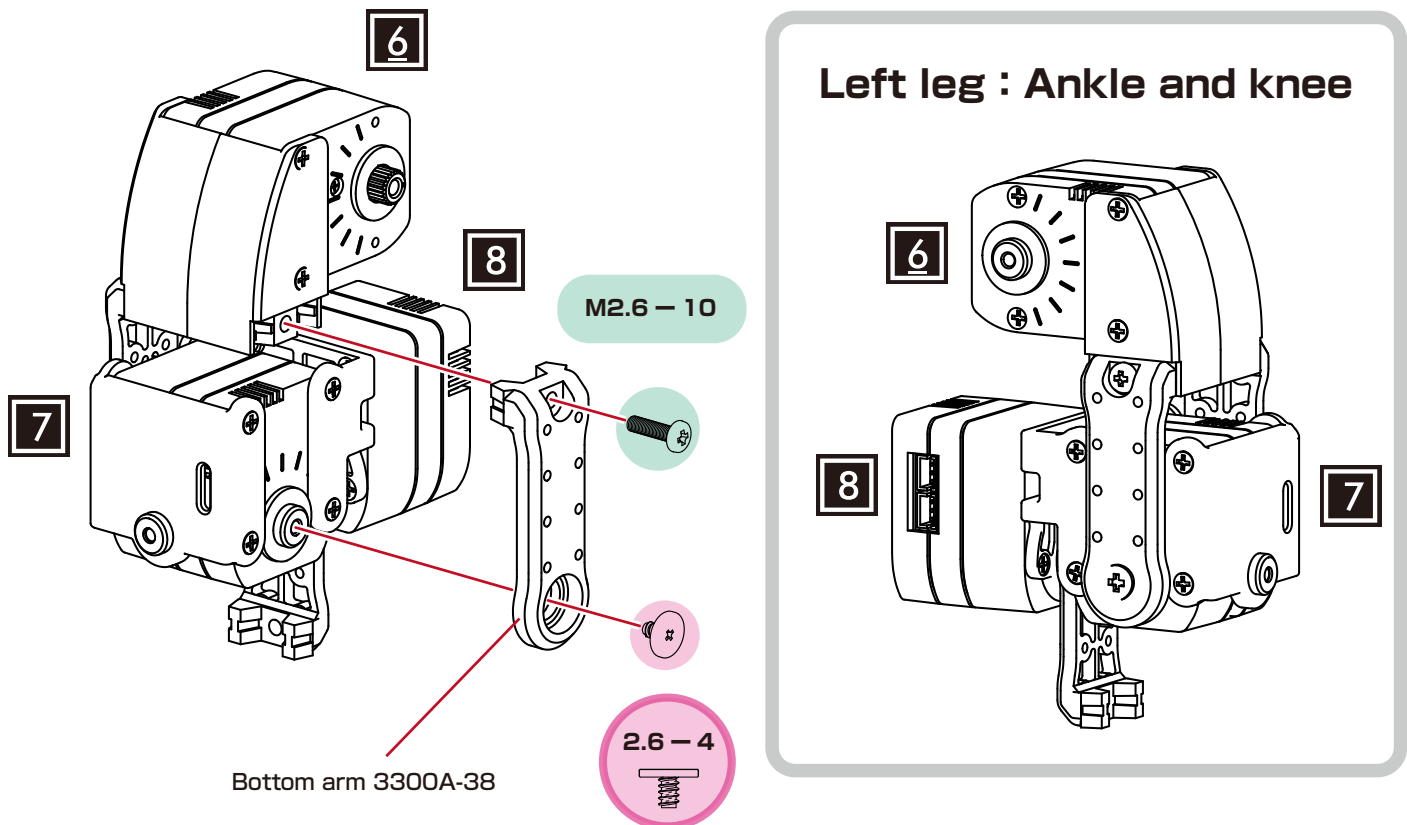

## Join the left leg.

### Parts used

- Upper arm 3300-20 x1
- Bottom arm 3300-20 x1
- Cross Bottom arm -28 x1
- Sole S03 x1
- Cable guide X x5
- Joint base A (Assembled) x1
- M2.6 - 10 x4
- M2 - 8 x4
- M2 - 6 x5
- M3 - 6 x1
- 2.6 - 4 x2

### Assemble part

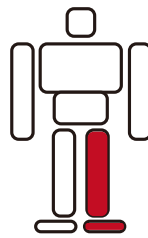

### Assembly parts completed

#### Left leg

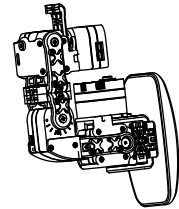

**A C H I**

1

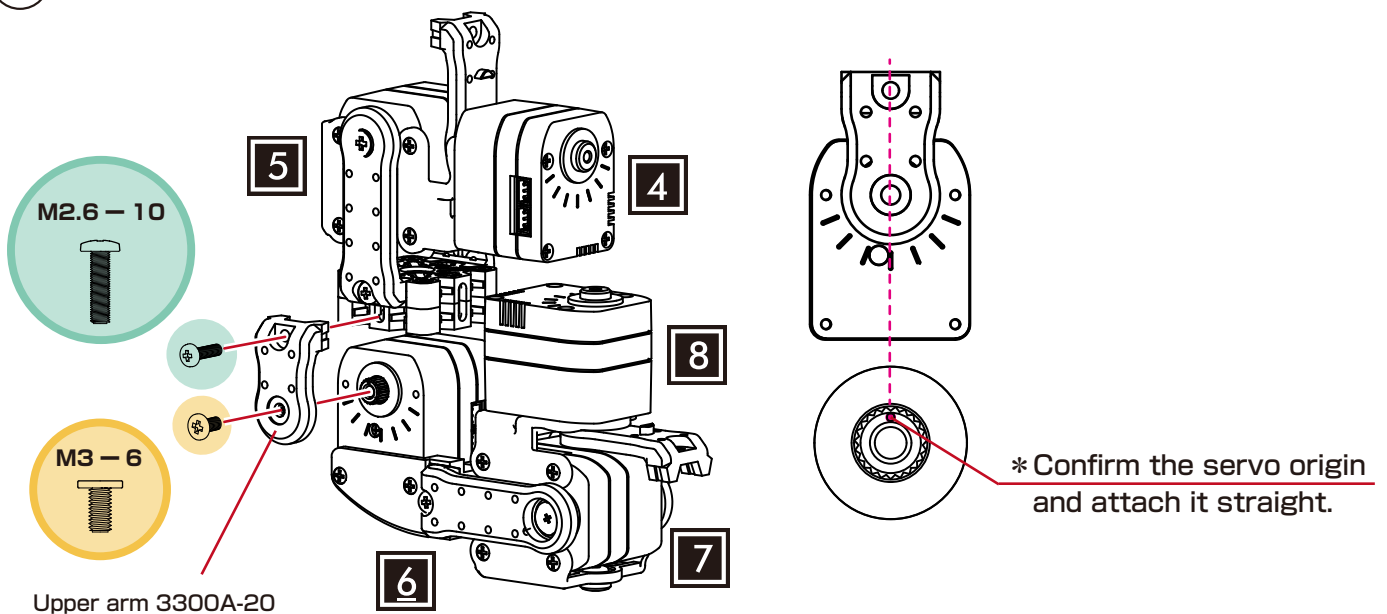

2

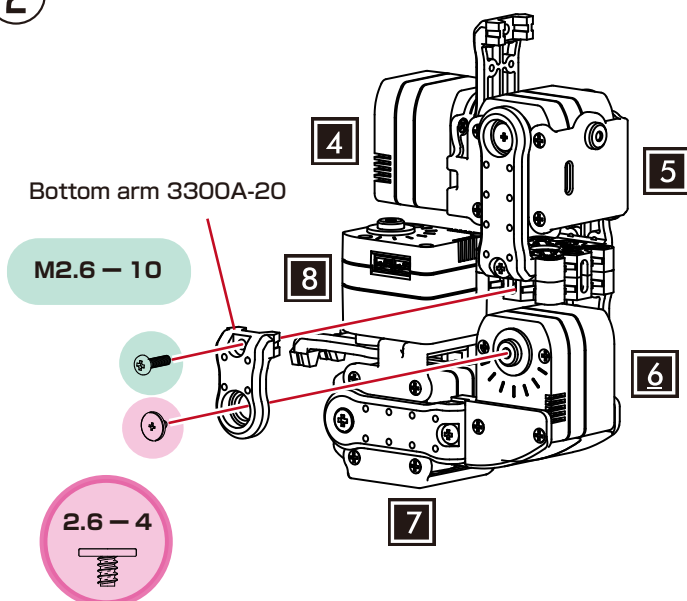

3

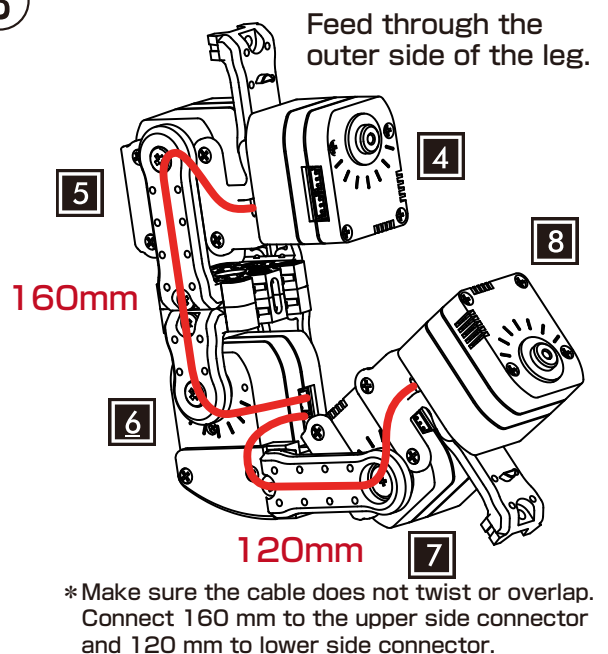

## ■ Assemble the sole and cable guide.

1

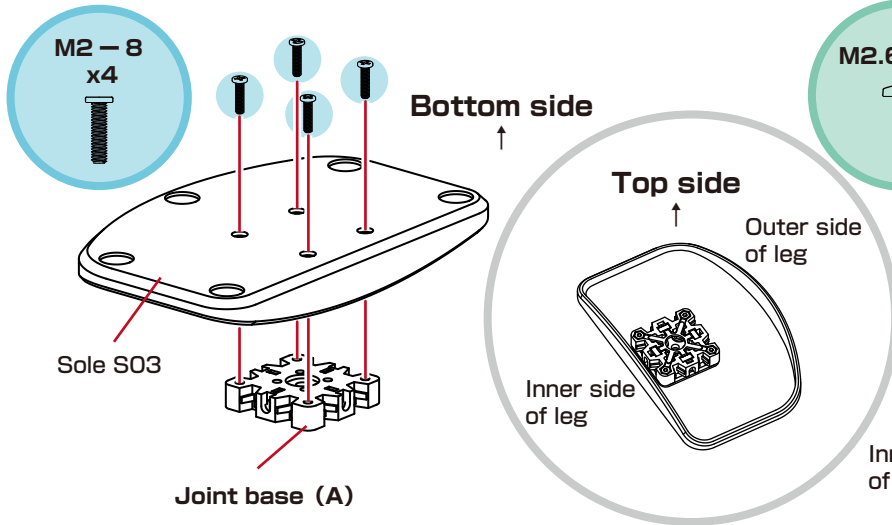

2

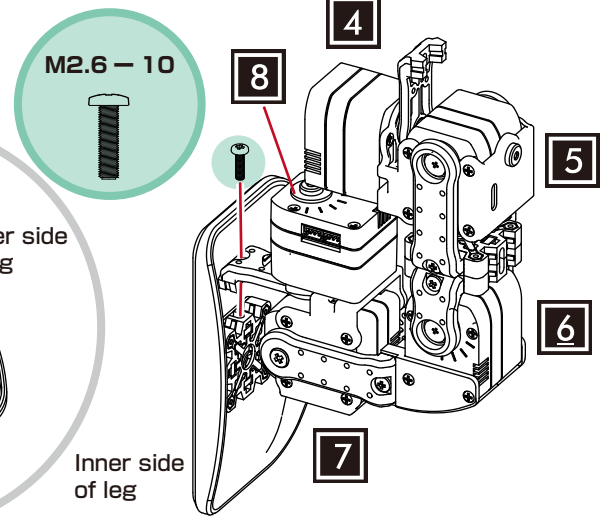

3

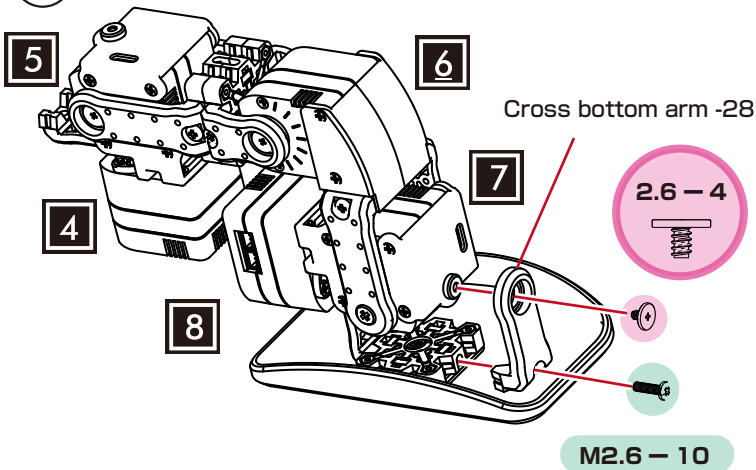

4

\* Move each joint and confirm that the cable is not stretched and that excessive force is not applied.

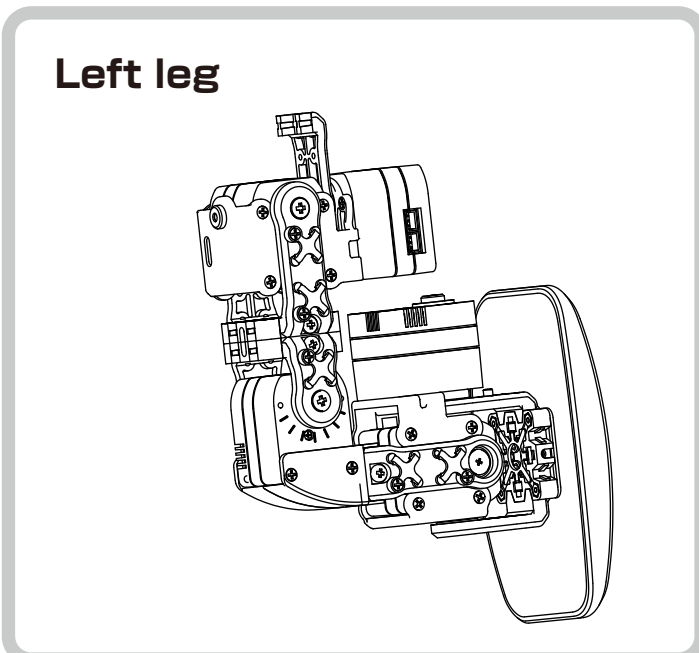
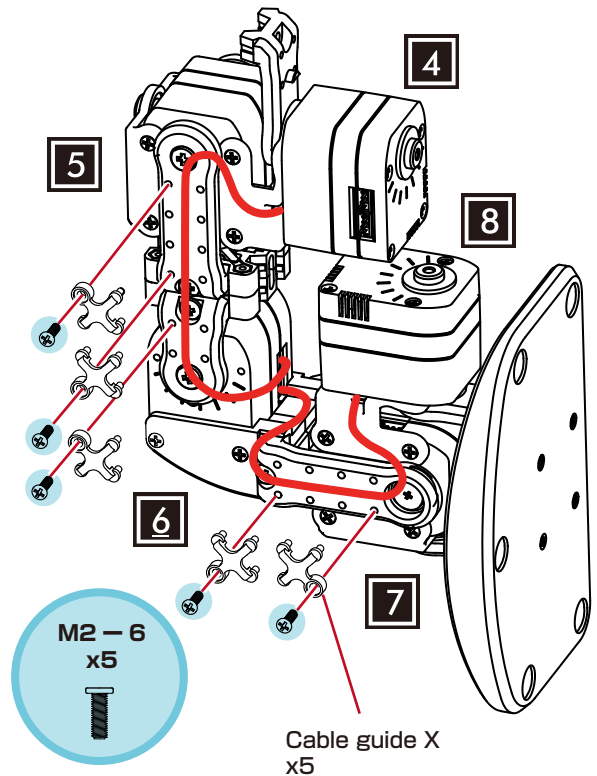

## ■ Attach the head to the body.

### Parts used

- Dummy Servo x1 (Assembled)
- Joint base x1
- Joint Nut x1
- Joint frame 3300B-a x1
- Joint frame 3300B-b x1
- M2.6 - 10 x2
- M2 - 4 x4
- M2 - 6 x4
- M3 - 8 x1

### Assemble part

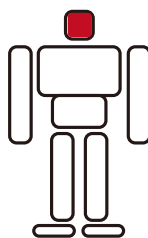

### Assembly parts completed

Parts combination :  
Head

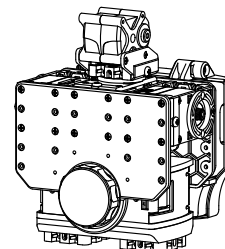

1

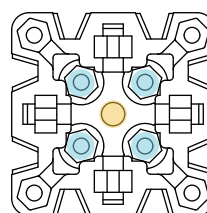
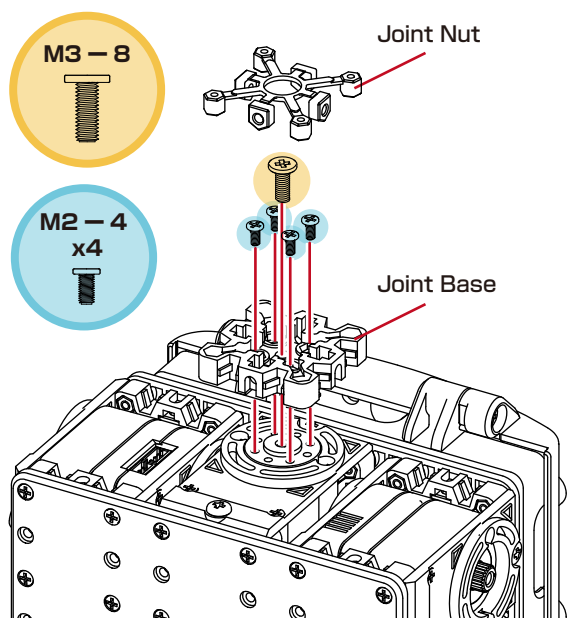

- M2 - 4
- M3 - 8

\* Use M3-8. Make sure the screw length is correct.

2 Attach joint frame 3300B to the joint base.

2-1.

Joint frame 3300B-b

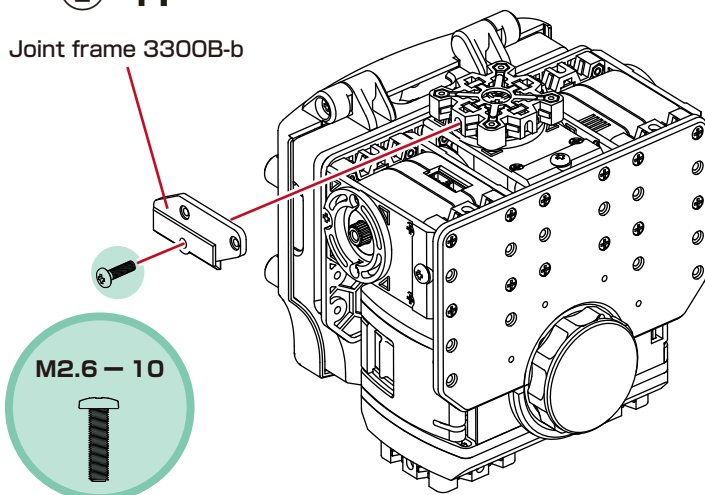

2-2.

Joint frame 3300B-a

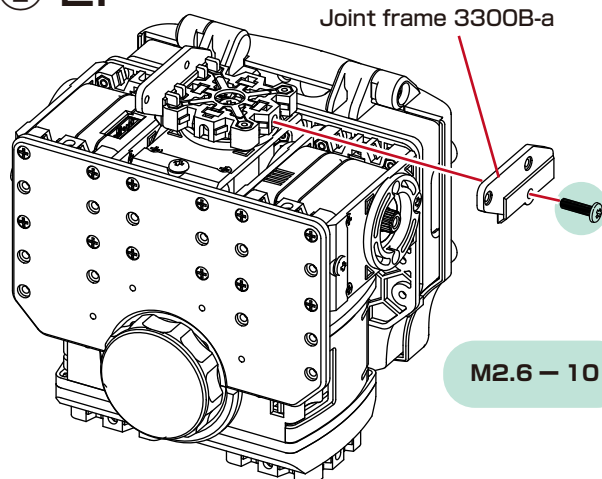

3

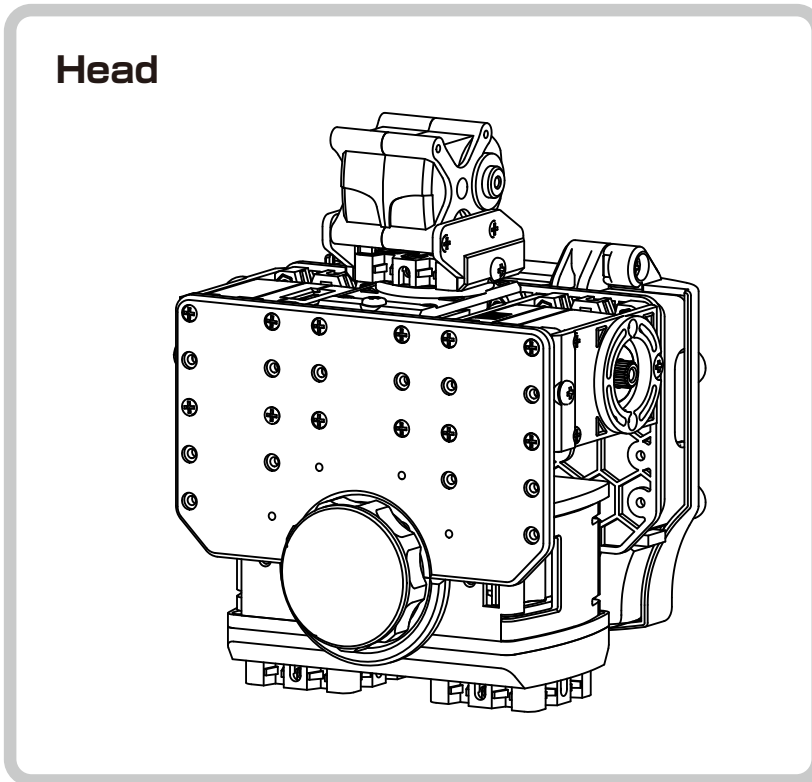
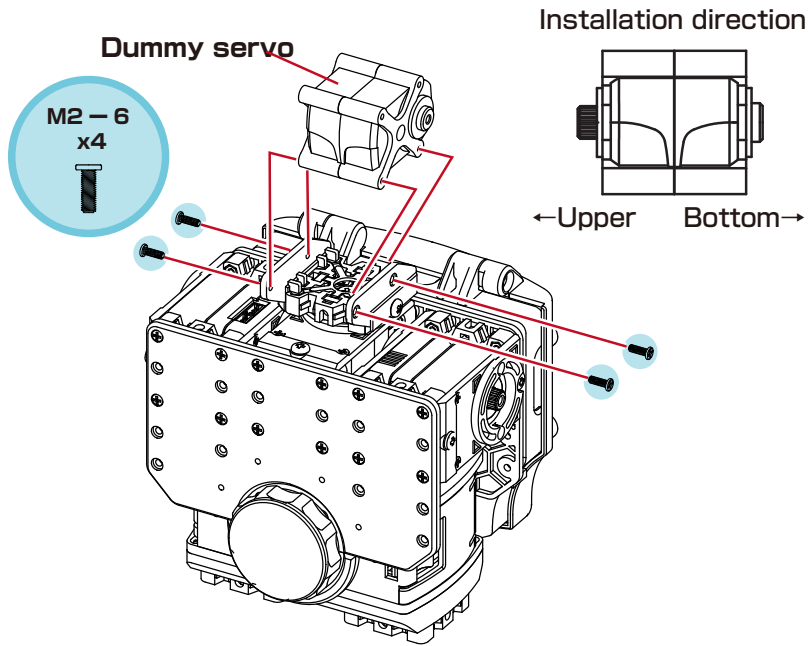



## Attach the right arm to the body.

### Parts used

- Horn B x1
- Joint base x1
- Joint Nut x1
- Bottom arm 3300-26 x1
- Cable guide X x1
- M2.6-10 x2
- M2-4 x4
- M2-6 x1
- M3-8 x1
- 2.6-4 x1



### Assemble part

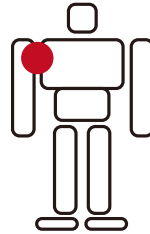

### Assembly parts completed

Parts combination :  
Right arm

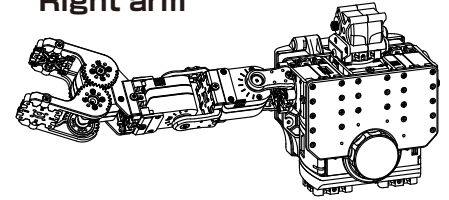

1

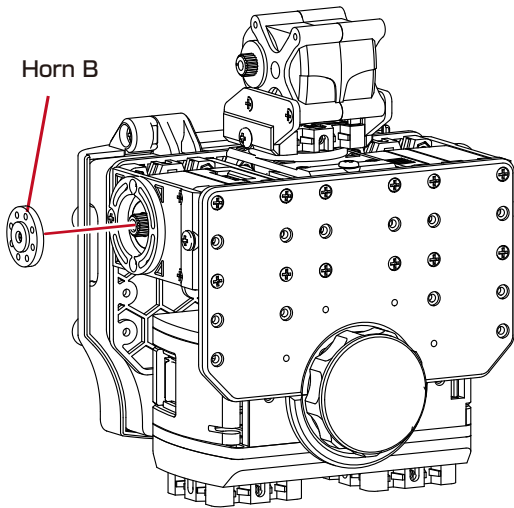

### Points on Attaching to Upper Shaft

**A**

Align with the servo origin mark.

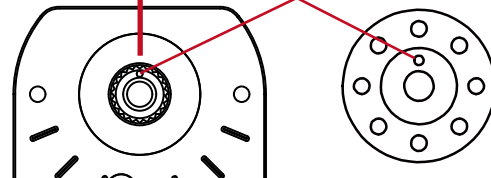

When the origin deviates with the diagram position, lightly insert the arm and rotate to adjust the position. Attach it straight toward the A line.

## 2 Attach the right shoulder joint.

\* Attach at a 45-degree angle in line with the support 2 mark.

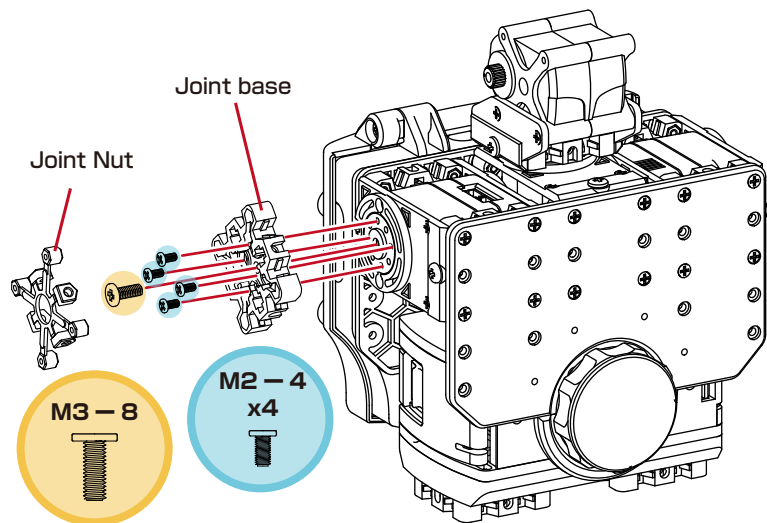
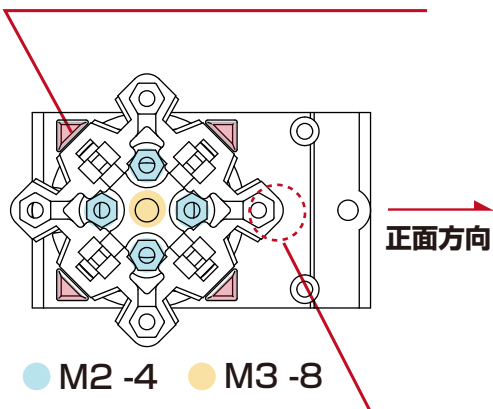

\* It would be helpful to use a paint marker pen, etc. to mark the front of the joint so that it is easy to find the origin even if the joint rotates before attaching the arm. (The nut M2 part can also be cut and marked.)

\* Use M3-8. Make sure the screw length is correct.

3

Bottom arm 3300-26

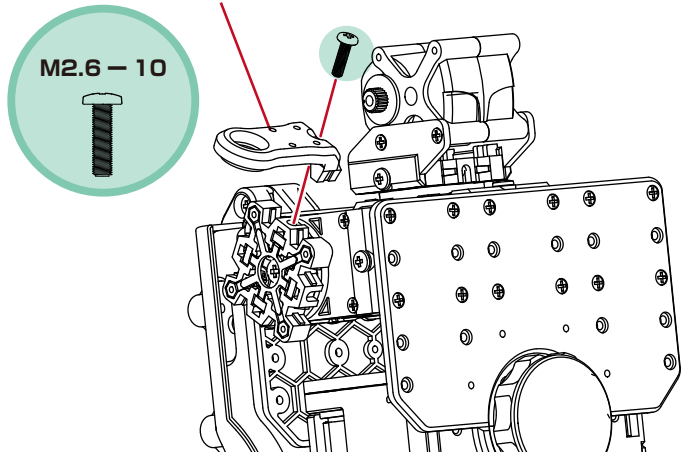

4

M2.6-10

Right arm

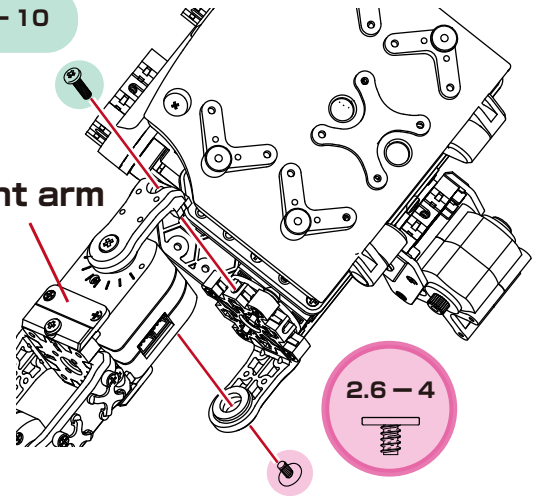

5

Confirm that the cable does not stretch or coil within the range of motion of the shoulder.

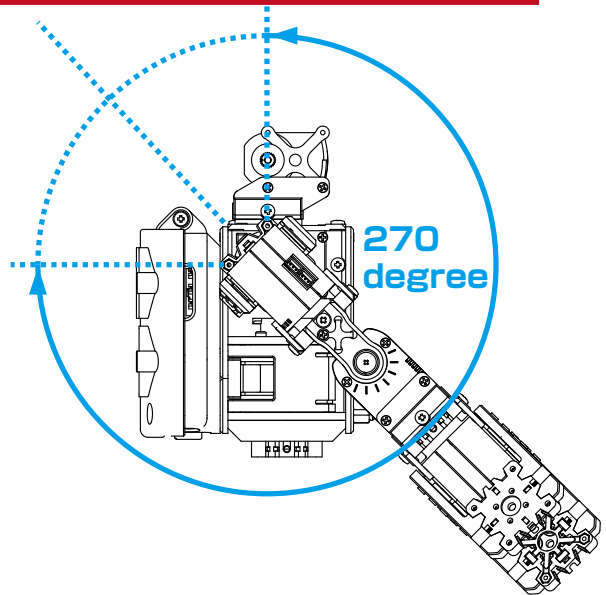
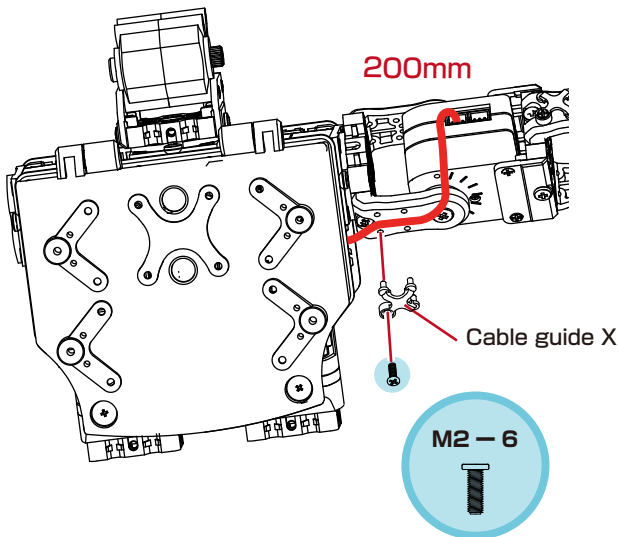

Right arm

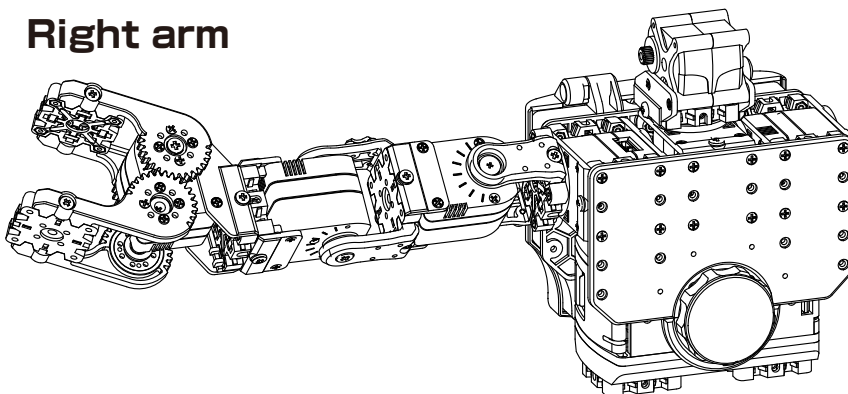

■ Attach the left arm to the body the same as the right arm.

### Parts used

- Horn B x1
- Joint base x1
- Joint Nut x1
- Bottom arm 3300-26 x1
- Cable guide X x1
- M2.6 -10 x2
- M2 -4 x4
- M2 -6 x1
- M3 -8 x1
- 2.6 -4 x1



### Assemble part

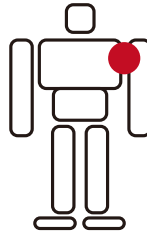

### Assembly parts completed

Parts combination :  
Left arm

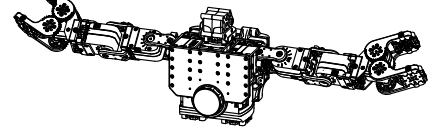

1

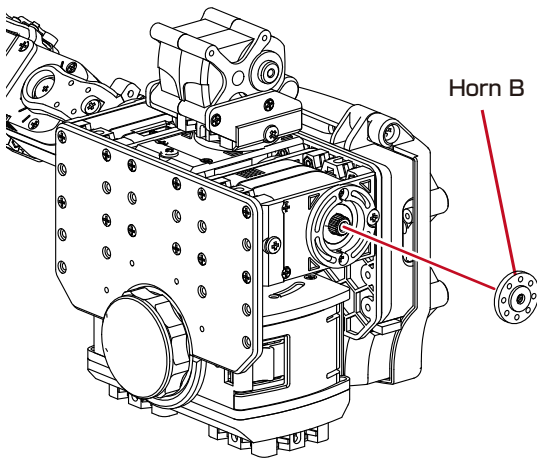

### Points on Attaching to Upper Shaft

**A**

Align with the servo origin mark.

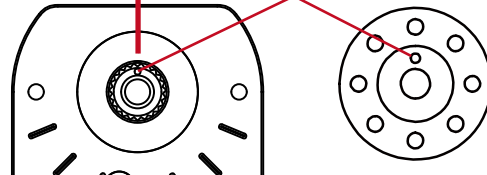

When the origin deviates with the diagram position, lightly insert the arm and rotate to adjust the position. Attach it straight toward the A line.

2 Attach the right shoulder joint.

\* Attach at a 45-degree angle in line with the support 2 mark.

Front direction

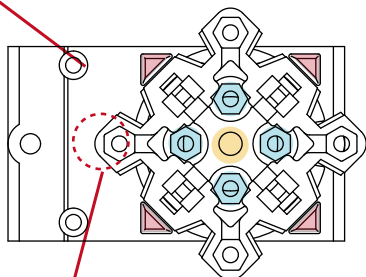

● M2 -4 ● M3 -8

\* It would be helpful to use a paint marker pen, etc. to mark the front of the joint so that it is easy to find the origin even if the joint rotates before attaching the arm. (The nut M2 part can also be cut and marked.)

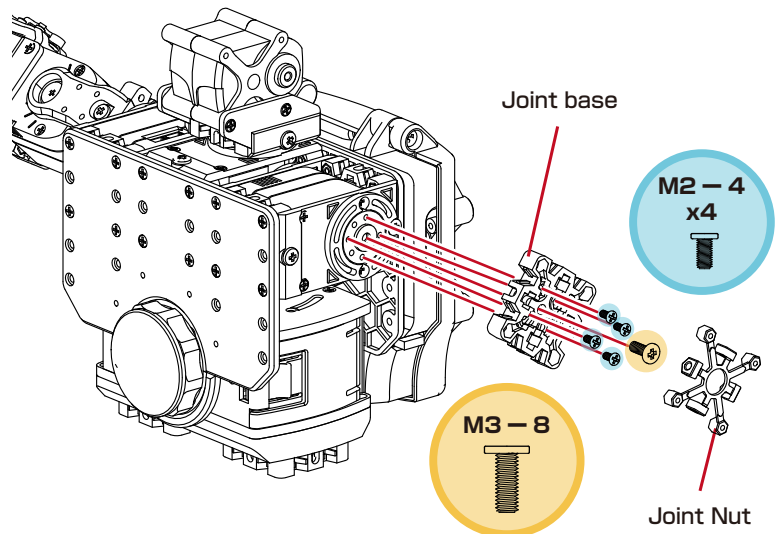

\* Use M3-8. Make sure the screw length is correct.

# Parts Combination 3 Left Arm

3

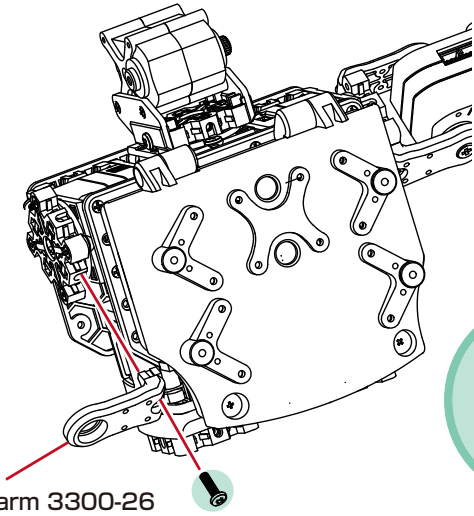

4

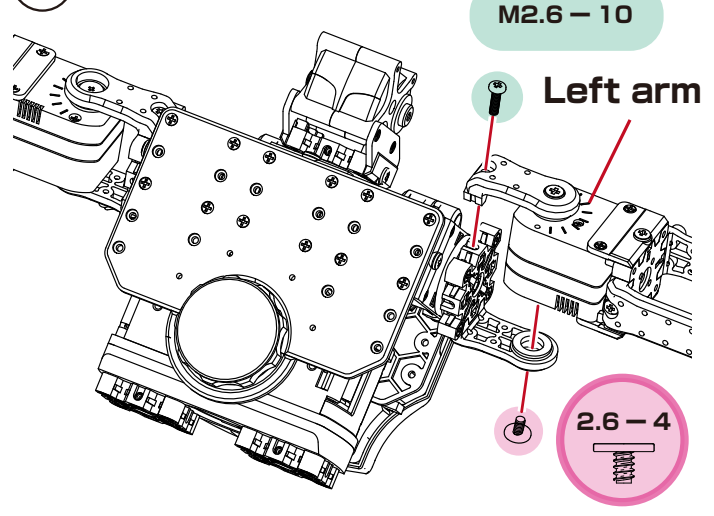

5

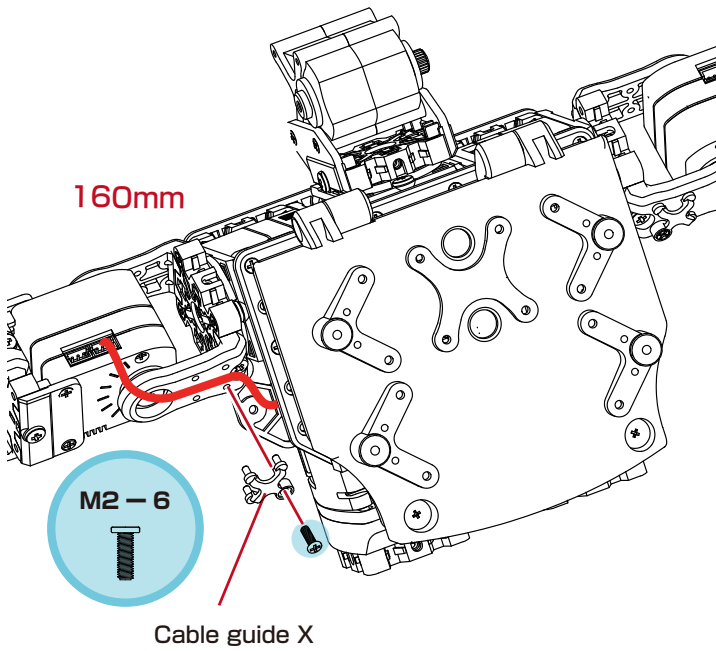

Confirm that the cable does not stretch or coil within the range of motion of the shoulder.

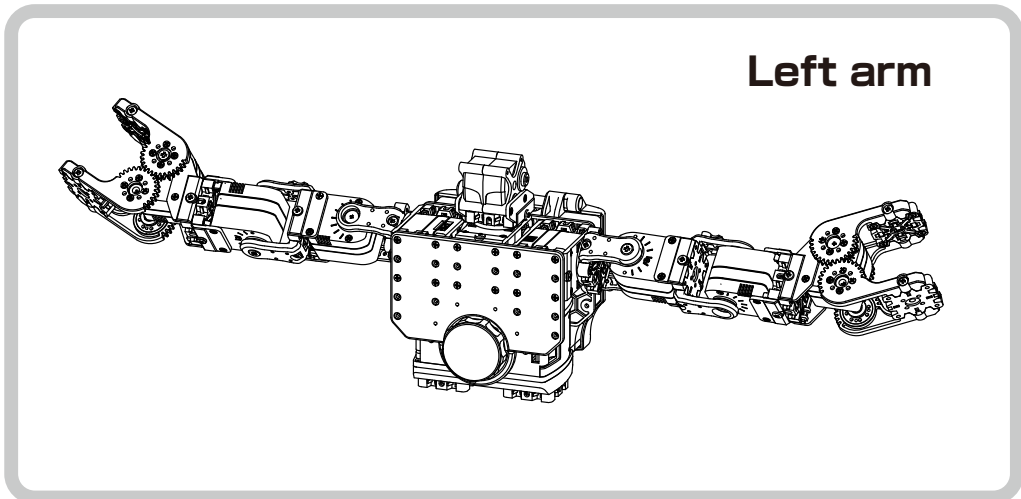
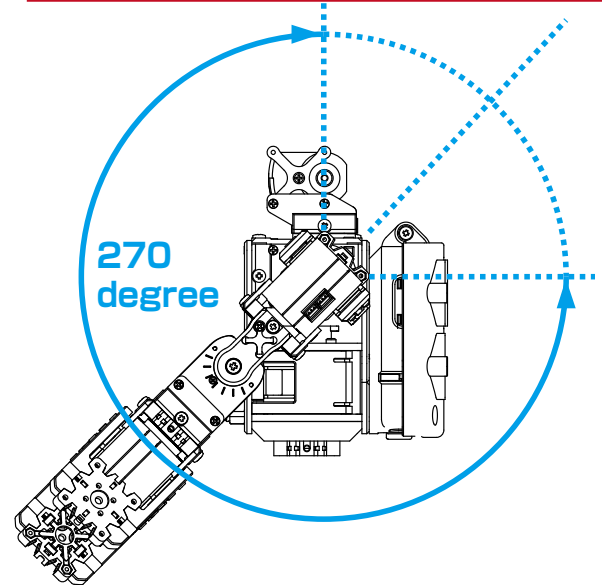

# Parts Combination 4 Right Leg

## ■ Attach the right leg.

### Parts used

- Cross bottom arm -28 x1
- Cable guide X x1
- M2.6 -10 x2
- M2 -6 x1
- 2.6 -4 x1

### Assemble part

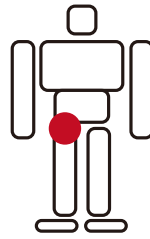

### Assembly parts completed

Parts combination :  
Right leg

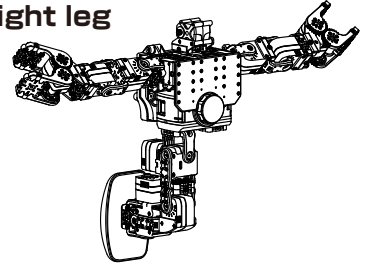

A H

1

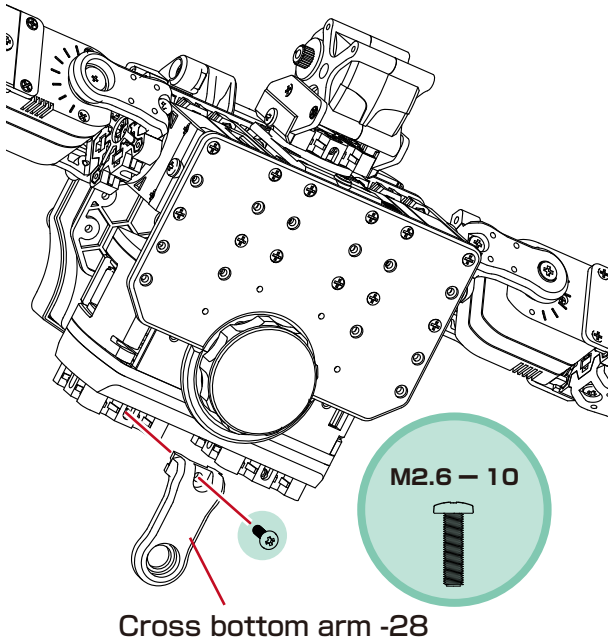

2

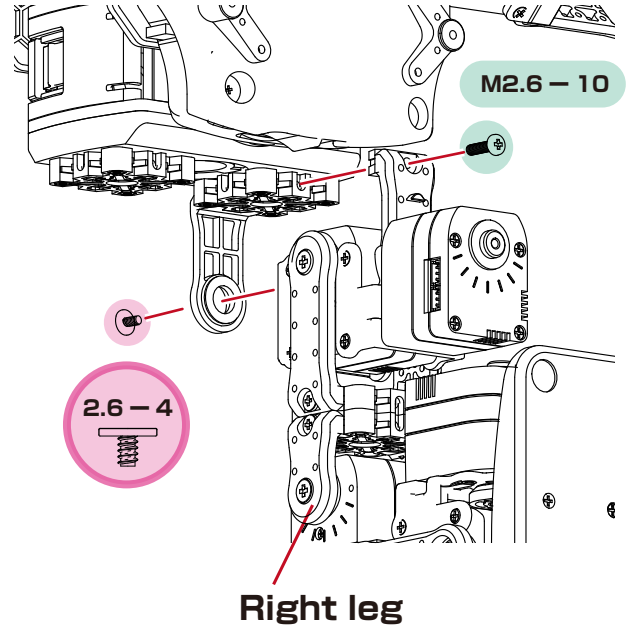

3

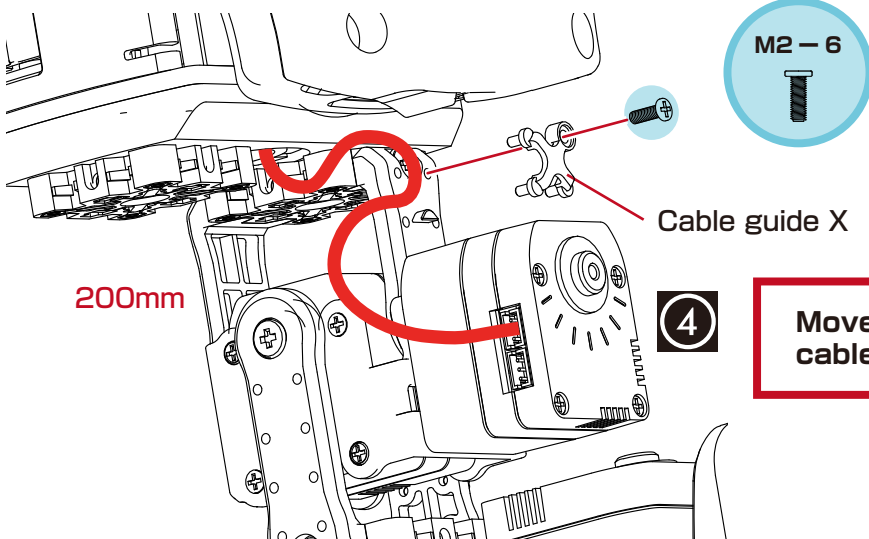

4

Move the leg and confirm that the cable is not stretched or coiled.



## Attach the left leg.

### Parts used

- Cross bottom arm -28 x1
- Cable guide X x1
- M2.6 -10 x2
- M2 -6 x1
- 2.6 -4 x1

### Assemble part

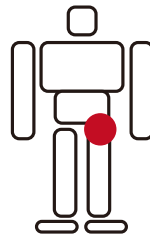

### Assembly parts completed

Parts combination :  
Left leg

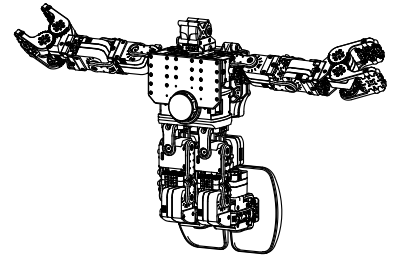

**A H**

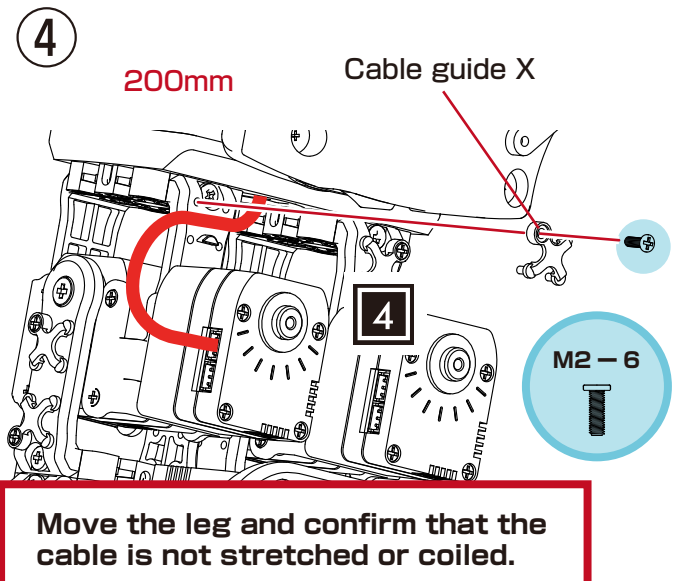
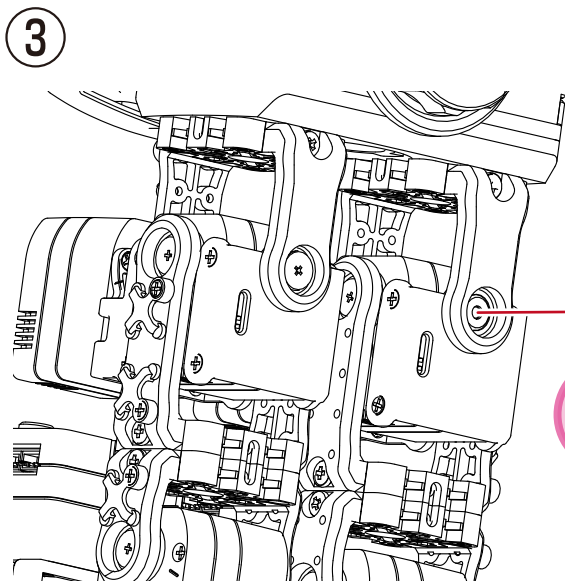
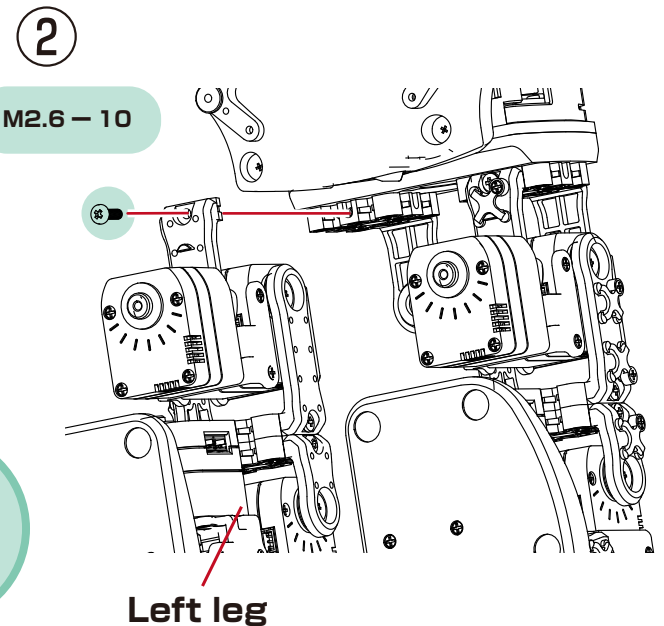
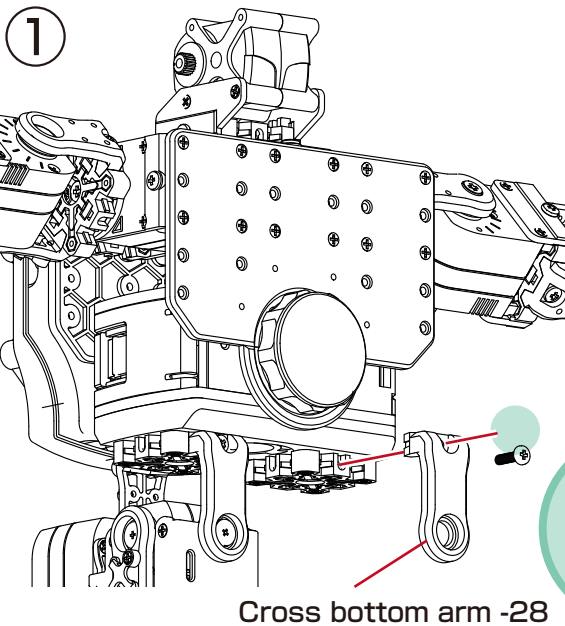



## ■ Attach the electronic components to the backpack and connect.

### Parts used

- RCB-4mini x1
- LV Power Source Switch Harness x1
- ZH Connection cable x1
- M2 - 6 x4
- 2.6 - 4 x6

### Assemble part

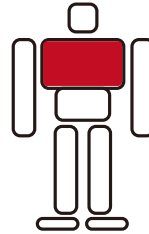

### Assembly parts completed

#### Backpack

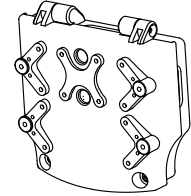

Confirm the electronic components for mounting.  
These three points are common to the KXR series.

### RCB-4mini

The control board for transferring motion data from the PC and moving the robot.

**ZH type-3PIN x12**  
To Servo etc.

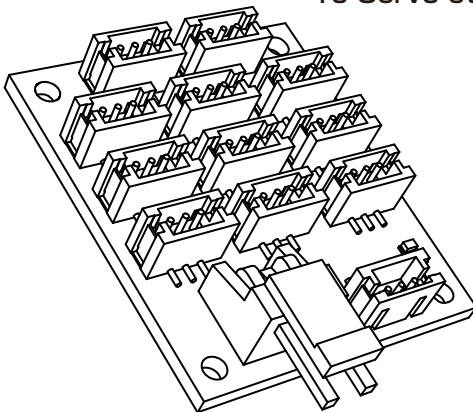

**VH type-2PIN**  
To power switch

### ZH Conversion Cable

Conversion cable for connecting serial extension cable connected with the PC and the RCB-4mini's COM port.

**Servo connector**  
To Serial Extension Cable (PC)



**ZH type-3PIN**  
To COM port

### LV Power Source Switch Harness

The white circle side is power ON. The power is normally OFF unless the robot is being operated.

**VH type-2PIN**  
To RCB-4mini

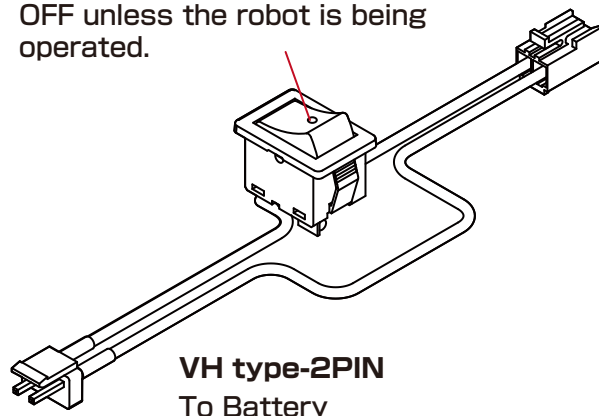

**VH type-2PIN**  
To Battery

### What are VH/ZH connectors?

These are the parts numbers of connector products from Japan Solderless Terminal (JST). With our company's products, VH is used for the main power and ZH or XH for serial communications.

**Be aware that even with the same type of connector, if the connection is wrong, it will cause a malfunction.**

① Attach the electronic components.

①-1. Attach RCB-4mini

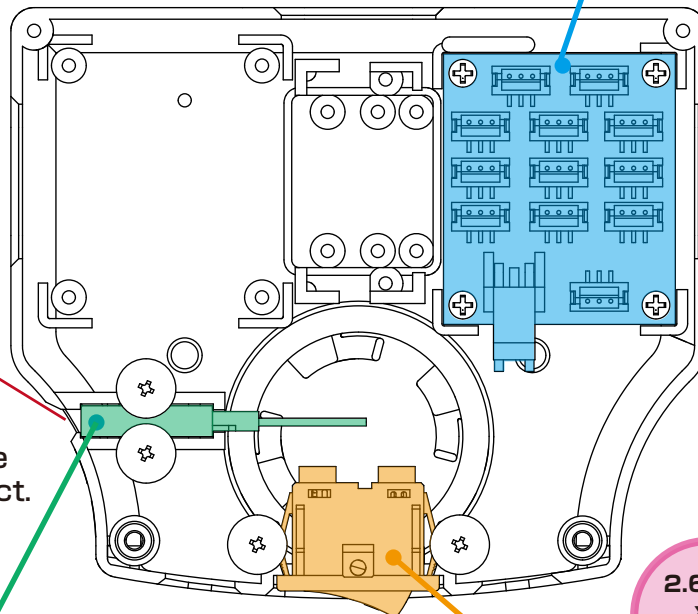
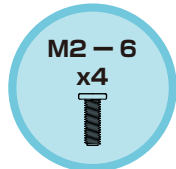
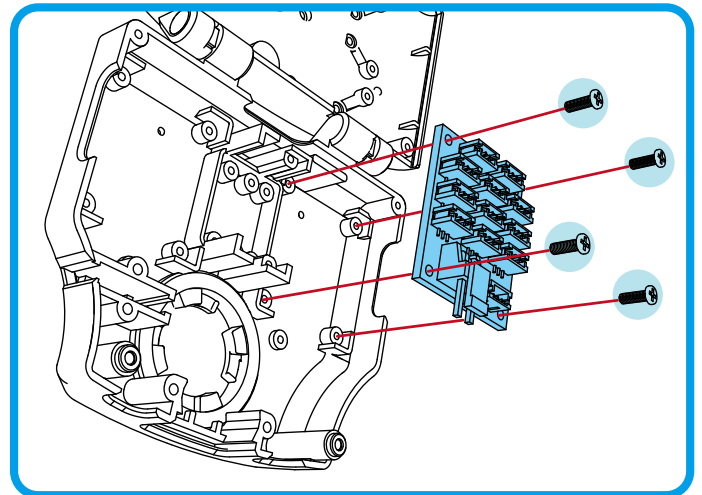

COM port

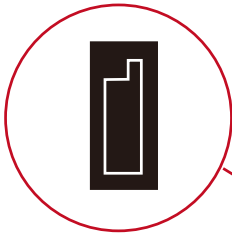

\* When inserting the connector, make sure the direction is correct.

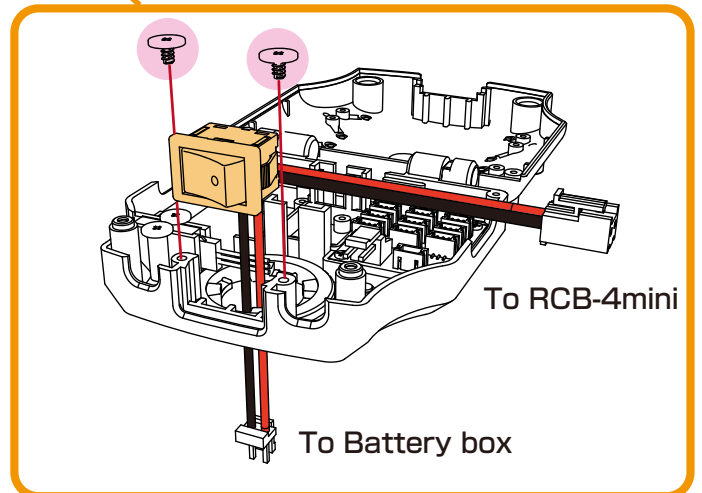
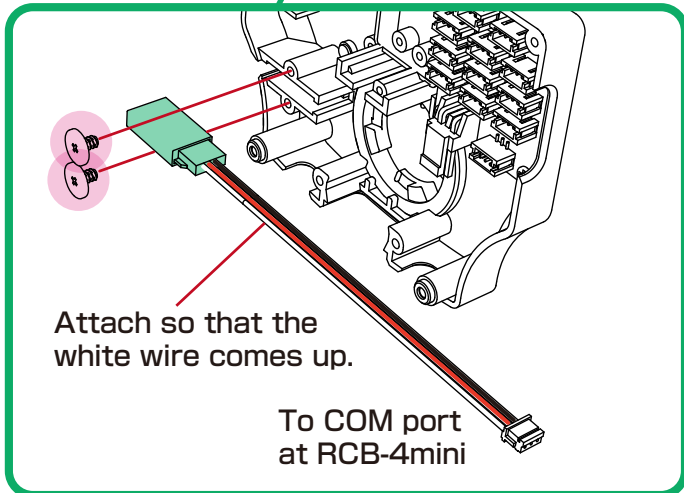
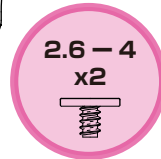
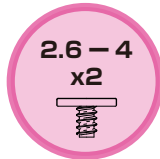

①-2. Attach ZH Conversion cable

①-3. Attach LV Power Source Switch Harness

② Connect wire.

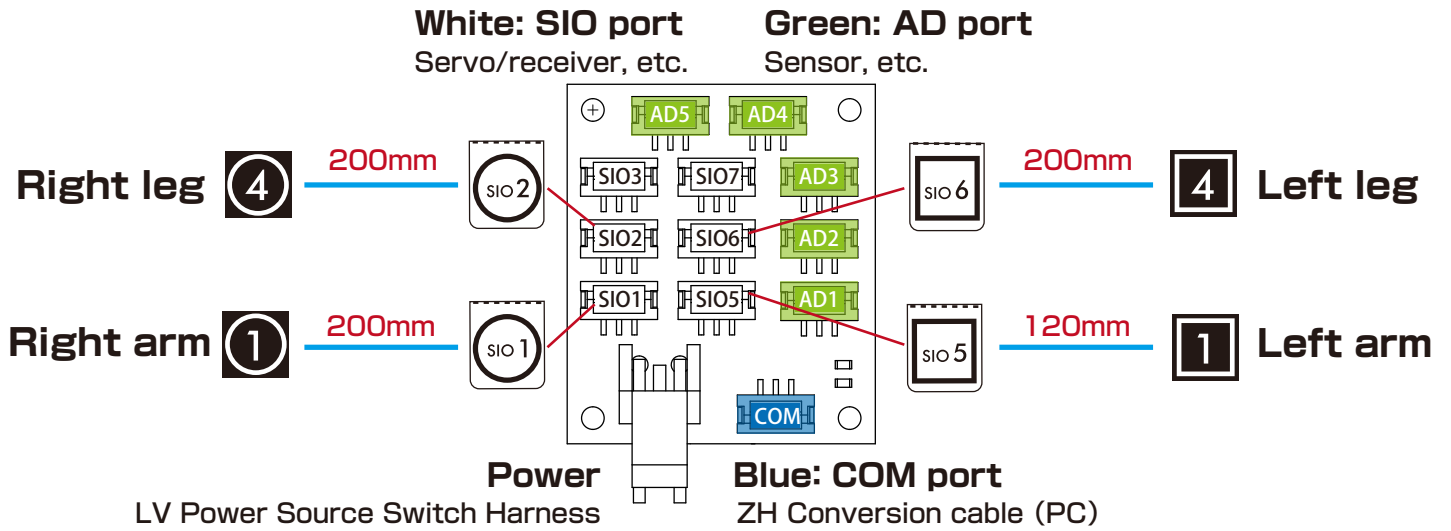

**\* When inserting the connector, make sure the direction is correct.**

**ZH type-3PIN**

**VH type-2PIN**

**ZH Conversion cable**

**LV Power Source Switch Harness**

Be careful of the protruding direction and do not force it in.

Be sure to confirm the lock/guide direction and that it is not connected backward.

## ■ Cover lock

When operating the robot, lock the cover with 2.6-4 screws so that it does not unexpectedly open and shut.

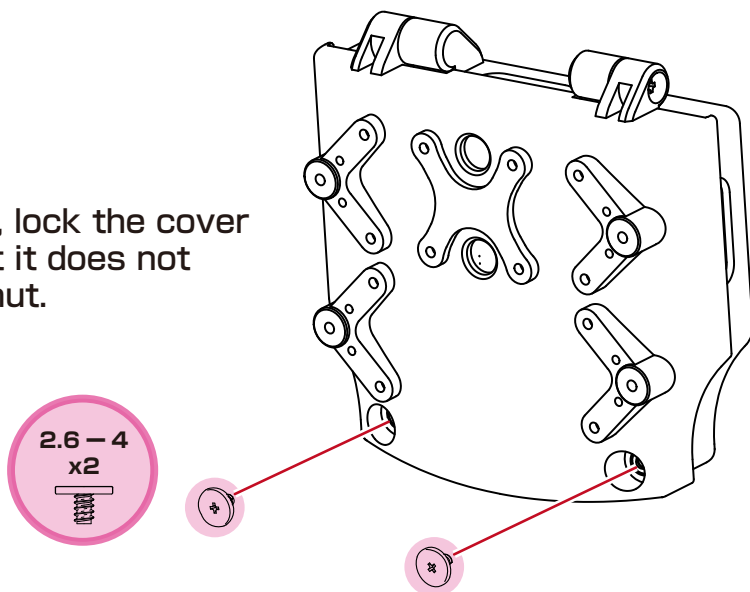

## ■ Assembly completed !

---

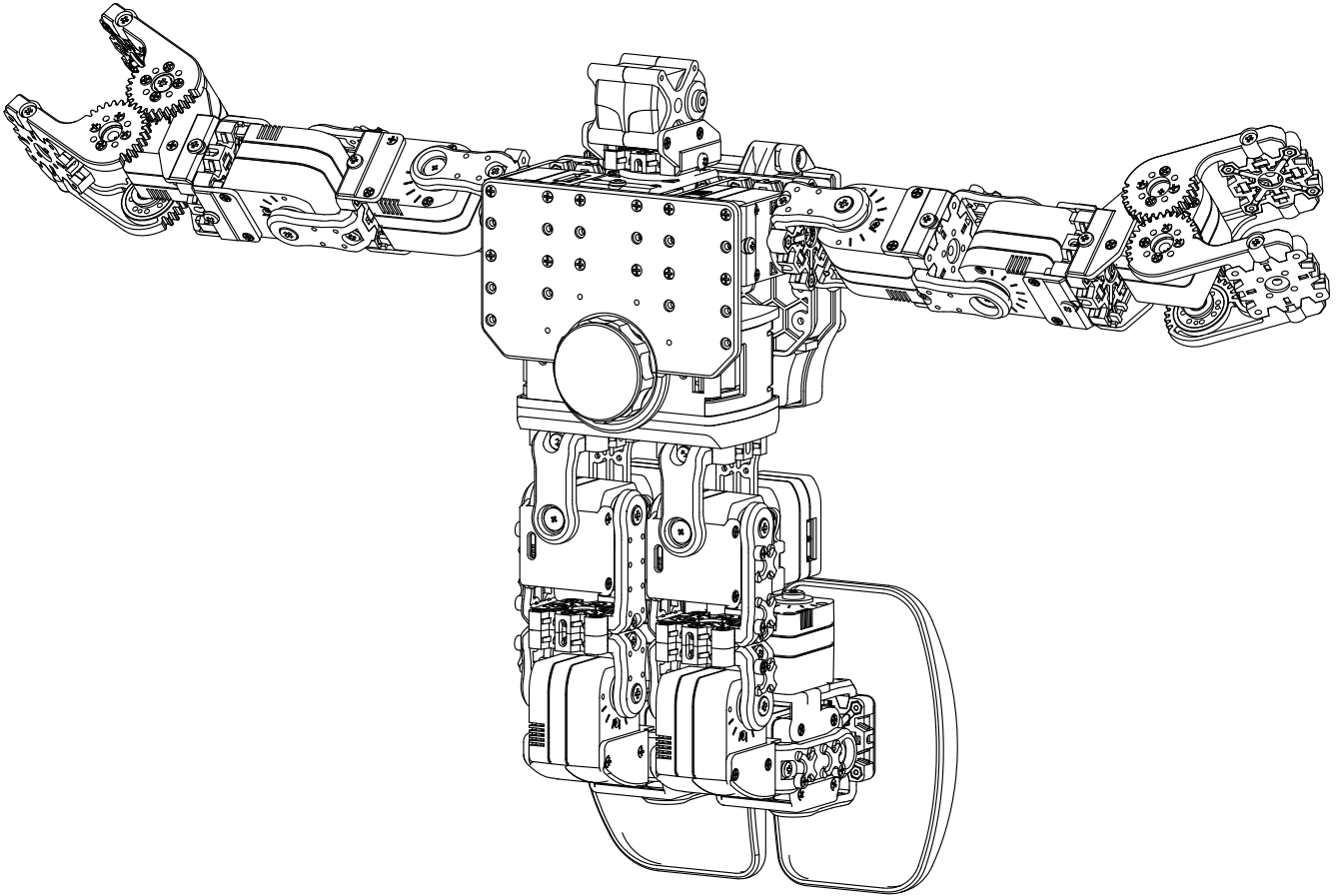

**The following will explain how to mount the battery and run motions.**

# Battery Mounting

## ■ Mount the battery.

**Before installation, check to be sure the power switch is OFF.  
Do not turn the power switch ON until connecting to the PC.**

Always read through the battery and charger manuals before use. Also, if using an LiFe battery, to prevent damage from over discharge, be sure to read about "Motion when voltage reduced (voltage check function on HTH4)" after the instructions for running motions.

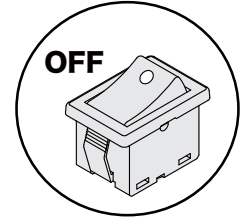

①-1. Push down lightly on the hatch clasp and slide it.



①-2. Once unlocked, the hatch opens on both sides.

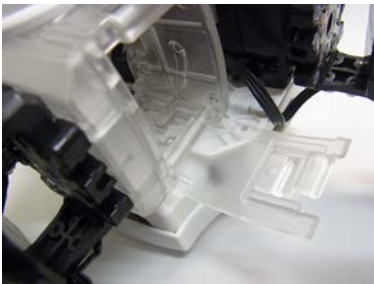

② Put in the battery in the direction of the photo so the connector goes in first.



\*Do not force the battery in. Check to see if it's catching on a cable.

③ Connect the connector.



\*It can be connected simply by holding down the connector in the box with the battery.



\*Be sure the polarity is correct. Connect cables of the same color so that the clasps join.

④ Close both sides of the hatch to complete the process.





# Connection with PC 1

In the following, adjustments are made to the robot using a computer. When all the processes are completed, the robot will begin to walk. Conduct the processes by following the procedures below.

## ▼ Process procedures

### Connecting with PC

- Install KO Driver
  - Connect the Dual USB adaptor HS to the PC
- Install the HTH4 (HeartToHeart4) motion creation software
  - Connect the robot to the PC
- Turn on the robot

### Run motion

- Adjust the trim
  - Adjust the posture for bilateral symmetry with the robot in the upright position.
- Run the sample motion
  - Enable the low voltage motion setting to prevent over discharge, and run the motion.

## ■ KO Driver Installation

KO Driver is driver software that enables Windows OS to recognize Kondo Kagaku's USB adaptor. This allows the servos and robot to communicate with the PC via a USB connection.

If KO driver has already been installed, it does not need to be installed again.

1. Set the Dual USB adapter HS switch to Serial mode, connect the Black-and-White Extension Cable, and then plug it into the USB port of your personal computer. When connected to the USB port in ICS mode, the Dual USB Adapter HS LED lights Green.
2. When connected to the Windows PC for the first time, the "Add New Hardware Wizard" will automatically run. Complete the setup following the KO Driver Installation Manual in the USB folder in the included CD-ROM.

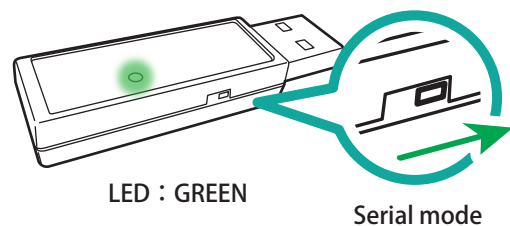

## ● Dual USB Adapter HS COM Confirmation

When the Dual USB Adapter HS driver installation is completed, confirm the "COM Port Number". This number is important when using the software, so please write it down. The method of confirming the COM number is included in the KO Driver Installation Manual in the USB folder in the included CD-ROM. Point Operation Tips Caution for Breakage Confirmation Required.



# Connection with PC 2

## ■ Install HeartToHeart4 Software

HTH4 (HeartToHeart4) is used to adjust the robot. The software is exclusively for RCB-4HV/RCB-4mini (referred to as “RCB-4” below) and has been designed to make it easy for anyone to control the robot. Using this software allows you to make full use of the functions needed to freely operate the robot, including the neutral position check (checks that parts have been assembled correctly with the servos in the origin (neutral) position), basic positioning adjustment (trim adjustment), motion creation, sensor settings, etc.

### 1. Software Installation

To install the software, double-click the "setup.exe" in the HeartToHeart4 folder in the CD-ROM included with the kit to automatically run the setup program. Continue the installation process as instructed by the setup program.

### 2. Software Activation

After completing the software installation, click the “HeartToHeart4” icon in the Windows Start Menu or on the Desktop to run the software.

When running HeartToHeart4 for the first time, a HeartToHeart4 folder is created in the My Document folder of your personal computer. Project files created must be saved in the “Projects” sub-folder in this folder.

### 3. Connecting Dual USB Adapter HS to the Robot

Connect the Serial Extension Cable to the Dual USB Adapter HS, and connect the other end to the port connector at the top of the KXR backpack.

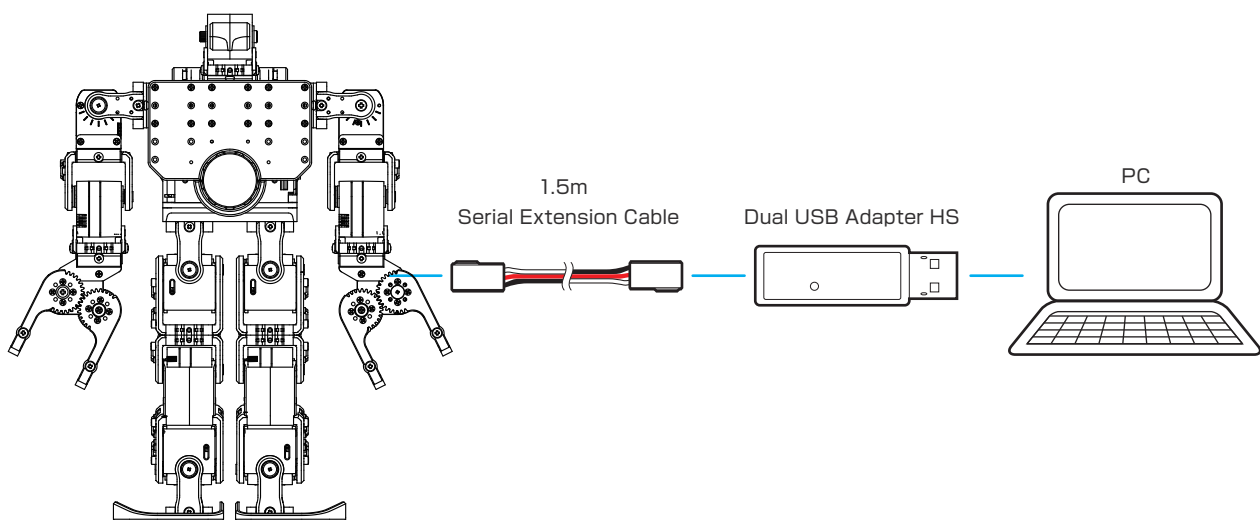

# Connection with PC 3

## 4. Copy Sample Data

Copy the "Sample\_Projects\_KXR (Vxx.x) " in the HeartToHeart4 folder on the CD-ROM to a convenient location on your personal computer.

In the example, it is copied to the desktop.

\* The version number differs depending on the kit and included CD-ROM.

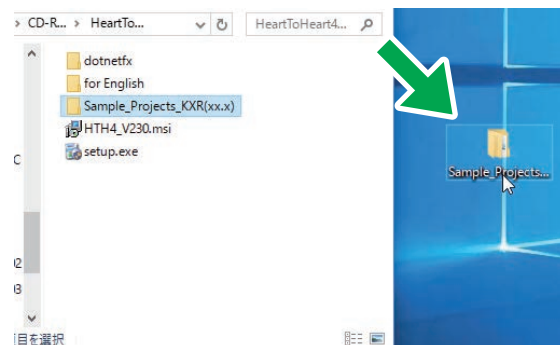

## 5. Activate KXR

Turn the KXR power switch ON.

### [IMPORTANT]

- Check the RCB-4 wiring and each servo motor once again before returning the power ON.
- Turning the power ON with connectors out of alignment, or the polarities reversed, may cause damage to the robot.
- If you notice anything abnormal when the power is on, such as a strange odor or a hot servo motor, immediately turn off the power and remove the battery.

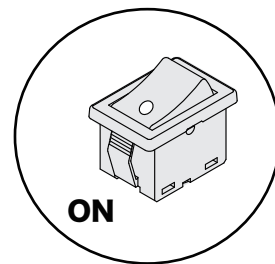

**When the power is turned on, all the servos will light up and then some of the servos will go out. The remaining servos will be lit up somewhat dimly. The robot will not move until you load the project (motion data) and run it, but this is its normal state.**

\*Servos with LEDs that turn on and off differ depending on the servo layout of the project example.

### [IMPORTANT]

- Always turn the power switch to OFF when temporarily away from the robot.
- When you are going to be away for a longer period of time, remove the battery connector for safety.
- Confirm that the battery is adequately charged before starting the robot.

**\*If the battery is not adequately charged when starting the robot, it may hinder subsequent operations.**

# Trim Adjustment 1

## ■ Trim Adjustment

Adjust the trim position before operating the robot. Trim adjustment refers to correcting slight deviations in servo origins that were not perceived during assembly.

The trim position is a pose in which only the trim is adjusted with the robot in its basic position.

The KXR-L2G standard is the robot with its arms extended. In the “Hello\_KXR-L2G (Vx.xx)” project, the “Trim Adjustment” tab (explained below) is preset so that KXR-L2G assumes the trim position. The next process involves adjusting deviations in each servo motor from the trim position.

In this process, put the robot in a completely upright position with bilateral symmetry. If you run a motion with the trim out of alignment, the robot will not function properly or topple over easily, so make sure to perform the process carefully.

## Types of Positions

### ● Neutral Position:

The state in which all servos are positioned to their Neutral (origin) position. This is used for confirmation after assembly.

### ● Trim Position:

The pose where only the trim is adjusted from the Neutral Position. This becomes the robot's basic posture. It is the upright standing posture for KXR-L2G, and is used when adjusting trim.

### ● Home Position:

The first and last position when motions are run. When the motion is completed, the robot returns to the home position, so if it stops partway through, check for motions that could not be performed, malfunctions or other such trouble.

# Trim Adjustment 2

## ● Setting Procedure

1. Click "File" -> "New" -> "Project" .

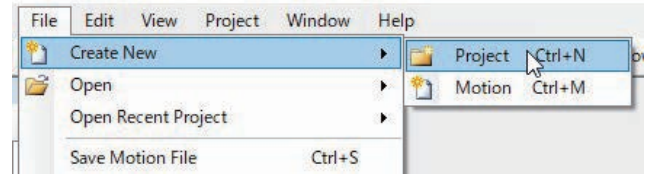

2. Click on the Project Import button.

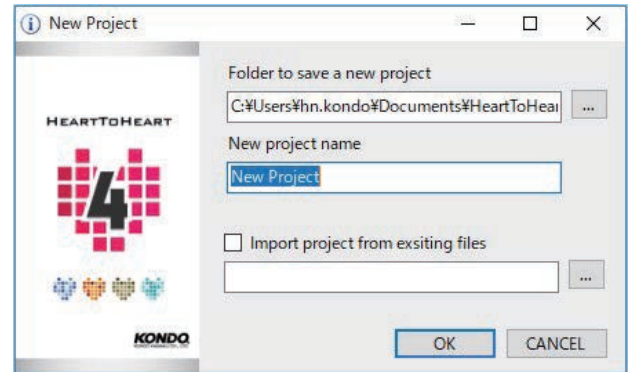

3. Select the "Hello\_KXR(Vxx.x)" project in the Sample\_projects (Vx.x) folder that was copied onto the computer above.

Hello\_KXR-L2G (Vxx.x)

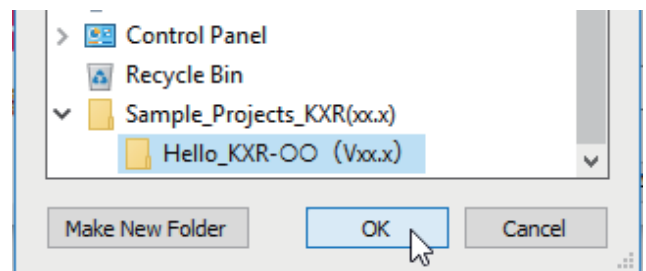

4. When the project is imported, the new project name in the New Project window becomes the same as the name of the folder that was imported.

If no change is made, press "OK".

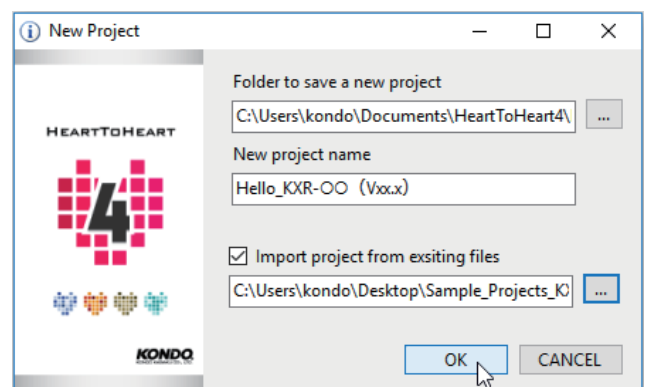

5. Assign the Communication Port (COM) number to be used. **This will typically be the COM number used for the KO Driver.**

In the initial state, there is a pull-down switch next to the "COM" button. When the button layout or window size is changed, the pull-down design will also change.

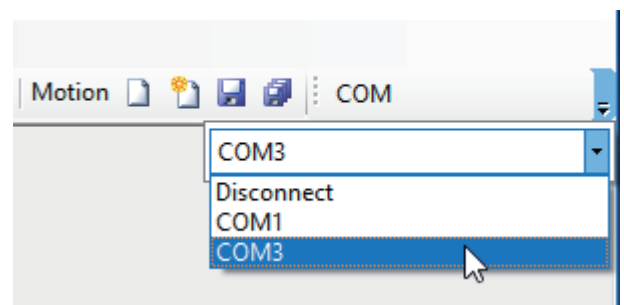

# Trim Adjustment 3

6. Press the "Project Setting Window" button. The Project Setting window opens when selected.



7. Set the COM communication rate and ICS communication rate to "115200".

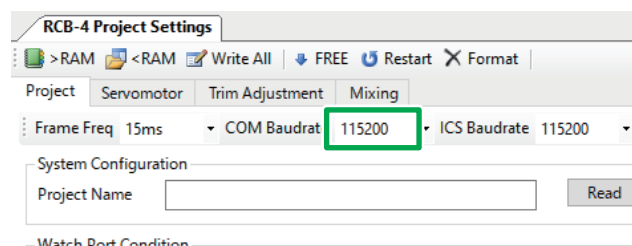

**Read the cautions on the next page before pressing the "RAM" button.**

8. Keep clicking on "RAM" button, allowing 2 to 3 seconds between each click until the robot slowly moves to trim position.

This applies when you run the robot for the first time. When the servos are shipped from the factory, there is no data loaded into them, thus the "RAM" button needs to be clicked multiple times for initialisation. Once initialised, pressing "RAM" once will be enough to get robot moving.

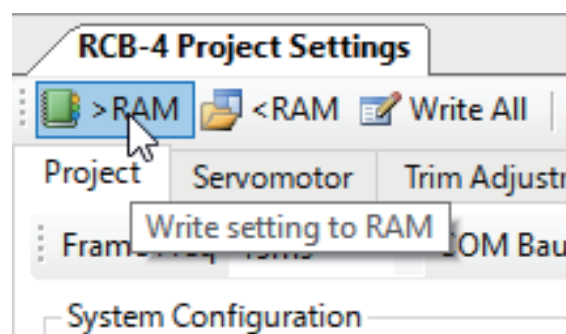

# Confirm Trim Position

The correct trim position is the pose shown in the diagram below. Press the “RAM” button and confirm that the robot assumes this pose.



When the RAM button is clicked, the robot will assume this posture. If the robot does not match this pose, then the origin setting is wrong. Retrace the origin setting steps to determine and correct the part that is off track. Proceeding to set the Home Position without confirming this posture can cause damage to the servo motors. Make sure that the robot assumes this posture before continuing any further.

When given power, a servo may vibrate slightly (hunting); this is not a malfunction. Hunting occurs when the stretch (holding force) is set at a high level to maintain neutral; when you press down lightly and hold it still, hunting will stop. In the upright position of the sample motion registered in the next step, stretch is set at a low level to help prevent hunting from occurring. If hunting does occur depending on the posture of the robot (when the robot is lifted up or shaken lightly, etc.), try holding the robot still.

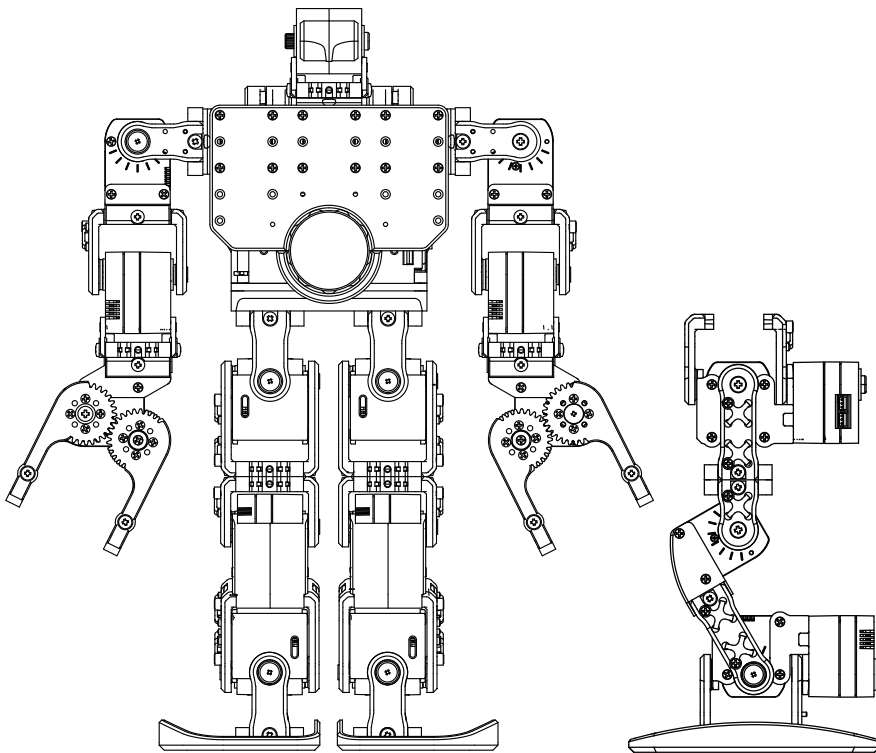

\* If the robot does not move, the following causes may be considered.

- **The KXR Power is not turned ON.**

Check the battery mounting, connections and turn the robot power ON.

- **The Switch Harness is not connected correctly to the RCB-4.**

Check the connection between the Switch Harness and the RCB-4HV.

\* Note: Make sure the power switch is OFF before proceeding.

- **The battery is not charged.**

If the robot does not move, even though the battery is correctly mounted and the power is turned ON, then the battery may not be charged. Charge the battery.

- **The RCB-4 and the computer communication rates do not match.**

Select "115200" for the COM communication rate in the Project Setting window.

**Once the correct posture is confirmed, proceed to the Trim Adjustment process.**



# Trim Adjustment 4

9. Click the "Trim Adjustment" tab at the top of the Project Setting window, to change screens.

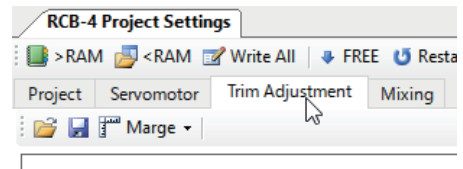

10. Press the "Sync" button in the toolbar of the Main Window. If the color of the button changes after pressing, it is turned ON.

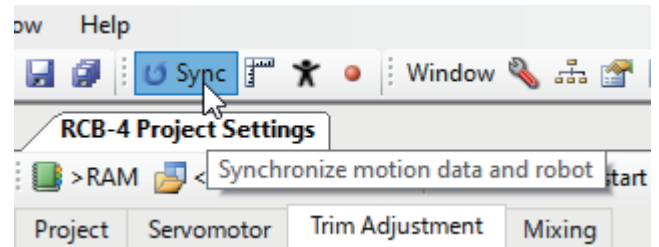

In the Sync state, the corresponding servo motor operates on a real-time basis by moving the HeartToHeart4 slide bar.

\*The screen layout is an example for reference purposes.

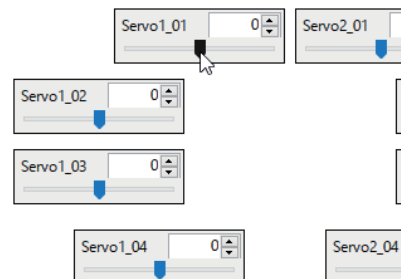

11. Adjust areas where the trim is out of alignment with reference to the image.

The trim position is an important base position for executing motions. In particular, if the left and right legs are not in perfect alignment, walking, etc. in the sample motion will not proceed smoothly. When the trim is out of alignment, the overall motion will also be off, so adjust the trim properly so that the robot stands perfectly upright.

# Trim Adjustment Points

## Trim Adjustment Points

Trim adjustment is particularly important for the lower body. The process will go smoothly if you adjust the hip joint servos in the order of ID4 to ID5.

**Also, adjust one side completely and then use that as the standard when adjusting the opposite side.**

Align the leg servos so that when looked at from the side their output shafts are lined up in a straight line.

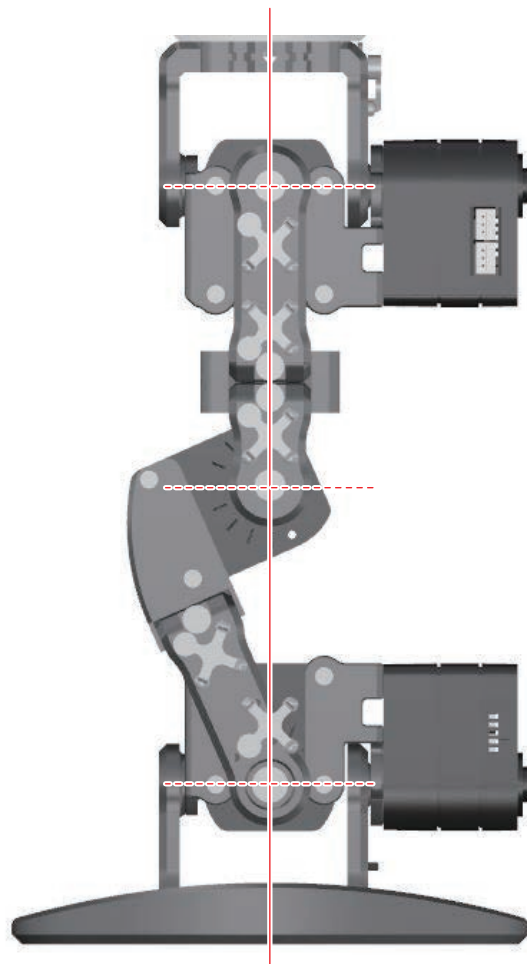

The position of the foot soles is particularly important. Make adjustments so the left and right foot soles are lined up on a single plane. If the left, right, front and back are not in alignment, the robot will not be stable.

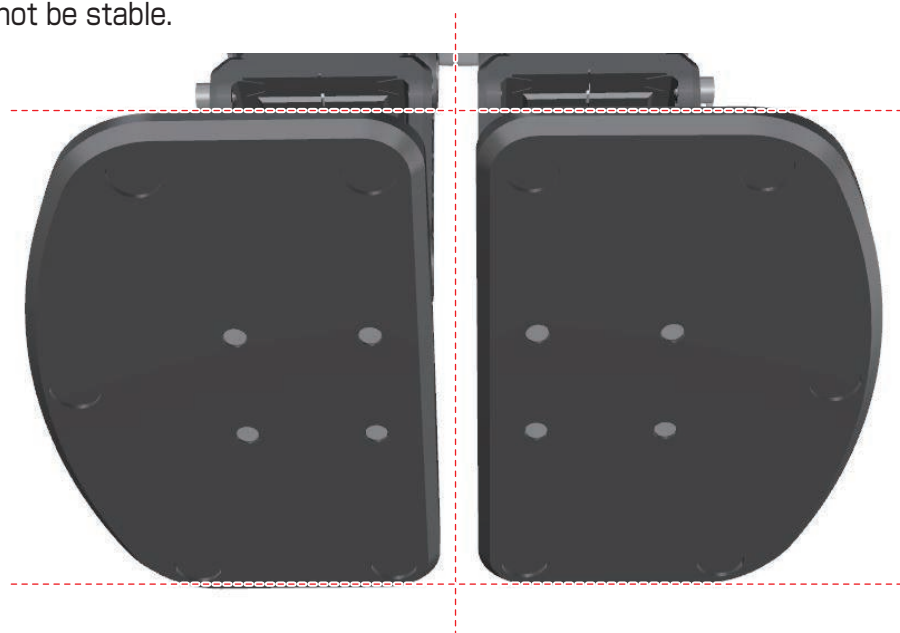

# Trim Adjustment 5

12. When all the Trim Adjustments are completed, press the "Save All to ROM" button in the Project Setting window.

13. The "Set Initial Posture at Start-up" dialog appears. Select the "Trim Position". Writing of the data to RCB-4 begins.

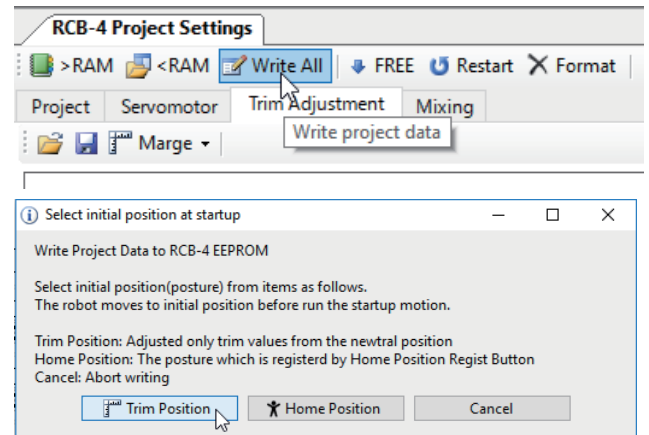

14. When the data writing is completed, a confirmation dialog asking "Do you want to restart your computer to reflect the changes made?" will appear; press "OK".

\*PC, HTH4 will not restart.

**When restarting, all of the robot servos will relax. To prevent the robot from falling, make sure to support the head or backpack while restarting.**

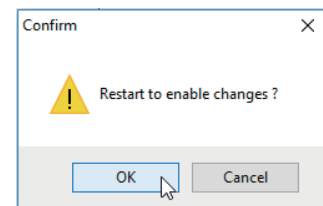
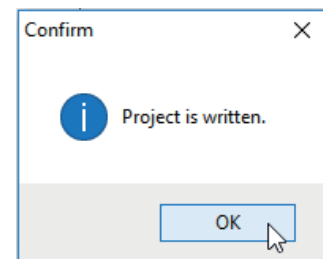
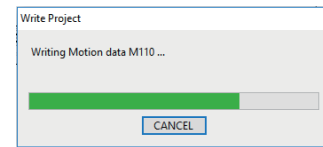

15. If the robot slowly and automatically moves to the set position after restarting, the Trim Adjustment is completed.

**\*The home position may differ with the project.**

16. Save the Project before quitting the software. Press the "Save Project" button in the toolbar of the Main Window.



17. When the saving is completed, the following dialog appears so press "OK".

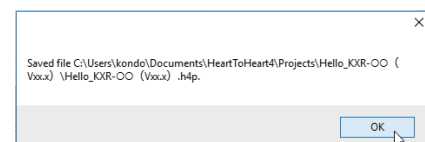

**\*If you close the application without saving, the project will not be saved.**

Next, run the sample motion.

If the process is interrupted, turn the power off on the robot and disconnect the battery.

# Running Sample Motions 1

## ■ Running Sample Motions

This will run the sample motions for KXR. If the robot keeps falling or does not move properly, try trimming the servos again.

The following uses "Hello\_KXR-L2G(Vxx.x)" as an example. Please refer to "Trim Adjustment" section if necessary.

**In the sample project, settings are enabled so that the reduced voltage motion will run automatically. If the battery runs low, other than the reduced voltage motion, the robot may move in unintended ways, lose power or otherwise operate abnormally.**

**First, charge (or replace) the battery.**

**(When using a LiFe battery and creating a new project, always enable the "Reduced voltage motion" setting.)**

## ● Setting Process

1. Press the "Motion List Window" button in the toolbar in the Main Window.

If it is already displayed, you do not need to press the button.

2. In the Motion List, click the motion name you wish to play.

3. Press the Play button in the Motion List window. **The robot will actually start moving as soon as the Play button is pressed, so please be careful.**

To play other motions, repeat steps 2 to 3.

If you wish to stop the robot during a motion, press the Stop button.

**In reduced voltage motion, servos are depowered. To return them to normal, turn the robot off and back on.**

4. Save Project before quitting the software. Press the "Save Project" button in the toolbar of the Main Window.

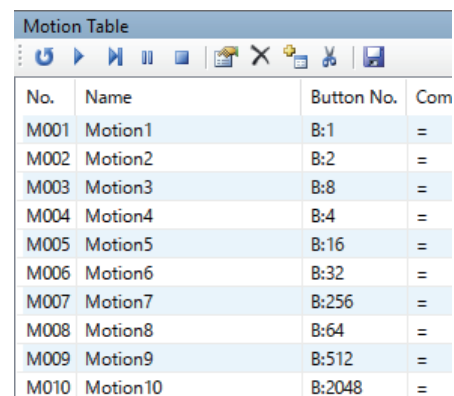
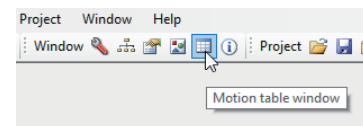

No.	Name	Button No.	Com
M001	Motion1	B:1	=
M002	Motion2	B:2	=
M003	Motion3	B:8	=
M004	Motion4	B:4	=
M005	Motion5	B:16	=
M006	Motion6	B:32	=
M007	Motion7	B:256	=
M008	Motion8	B:64	=
M009	Motion9	B:512	=
M010	Motion10	B:2048	=

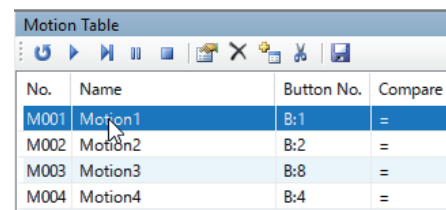

No.	Name	Button No.	Compare
M001	Motion1	B:1	=
M002	Motion2	B:2	=
M003	Motion3	B:8	=
M004	Motion4	B:4	=

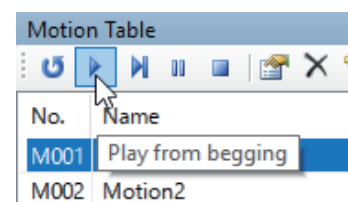

No.	Name
M001	Play from begging
M002	Motion2



# Running Sample Motions 2

5. When saving is completed, the following dialog appears so press "OK".

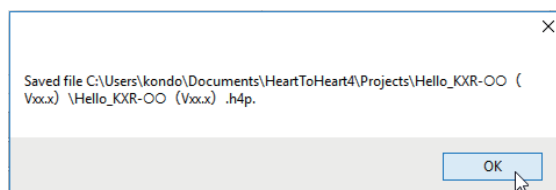

## ● Try Running a Motion with KRC Commander

Motions can also be run through "KRC Commander". Select "KRC Commander" from "Window" menu. The motion assigned to the button data is sent to the robot by pressing the button shown in the window. For detailed instructions, please refer to "HeartToHeart4 User's Manual".

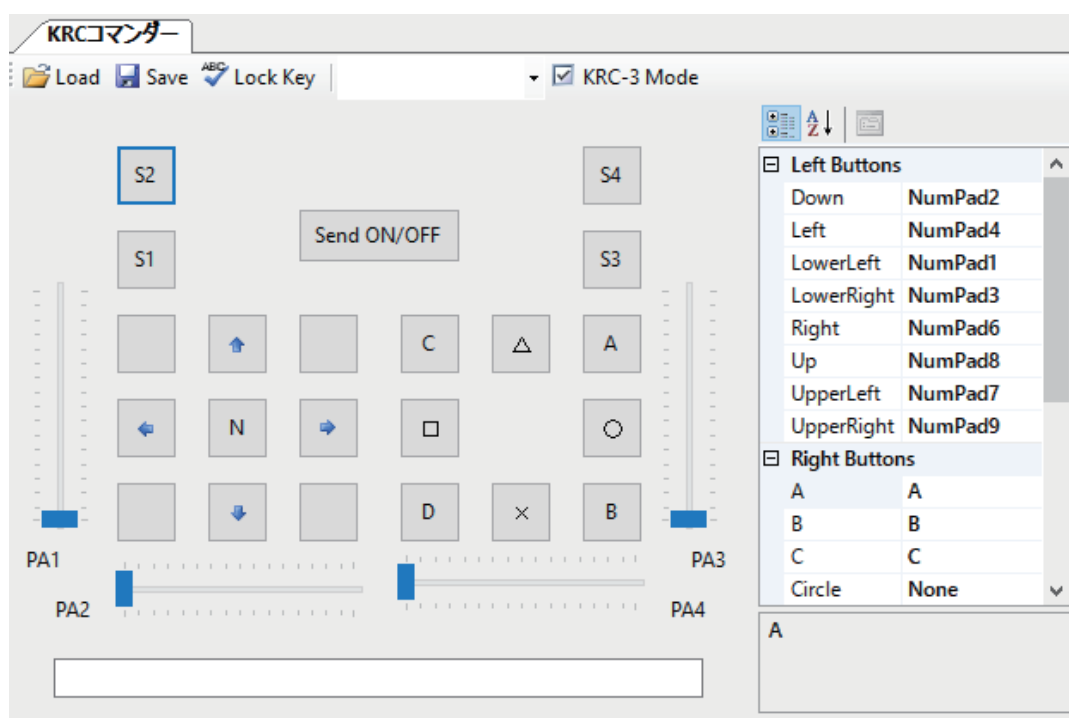

- \* For usage details, refer to the "HeartToHeart4 User's Manual."
- \* Use button assignments as they are with wireless control on KRC-5FH.

# Running Sample Motions 3

## ■ Operate with KRC Commander

### ● Usage Method

1. Click “KRC Commander” from the Windows menu and open the KRC Commander window.

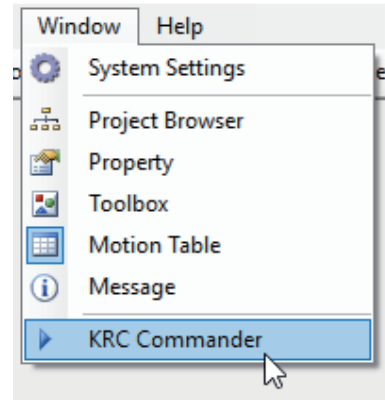

The KRC Commander screen opens. Motions can be assigned to each button and operated. Refer to the sample motion assignment list at the end of this section.

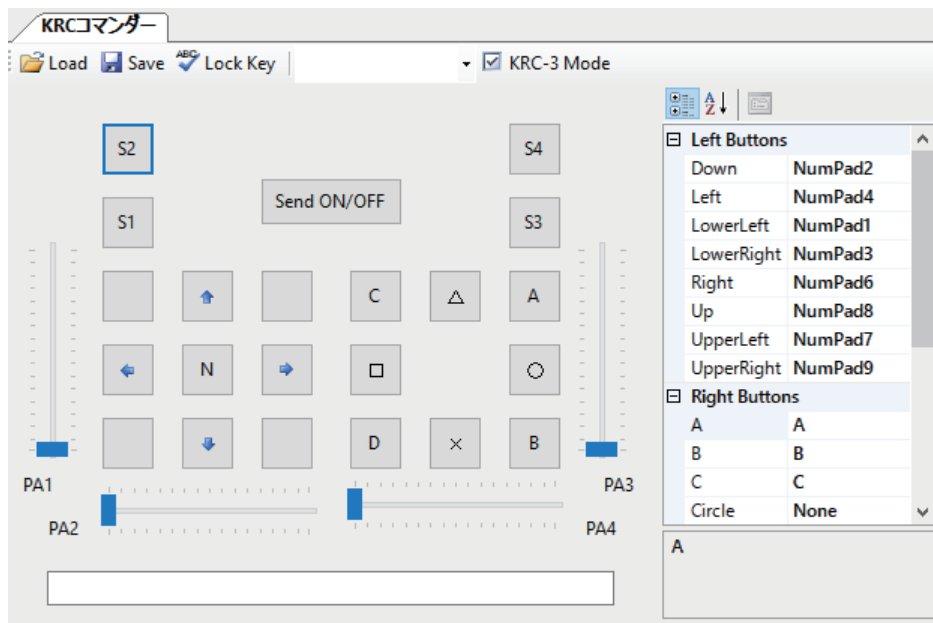

2. Click the “Send ON/OFF” button to start communications with the robot.

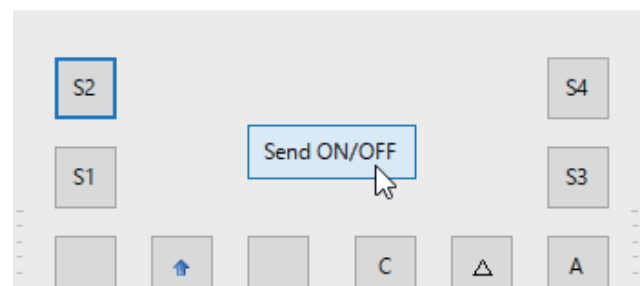



# Running Sample Motions 4

3. As with wireless control, click one of the buttons and the corresponding motion will run. For motions like walk motion that run continuously when the button is held down, the same continuous motion can be performed by continuing to click the button.

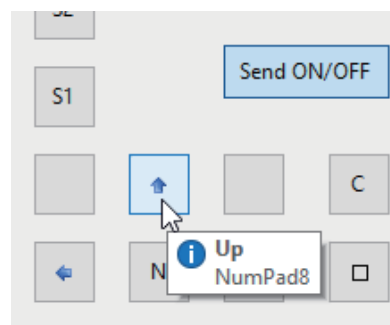

4. Click "LockKey" when executing a combination of buttons. With LockKey clicked, when you press a button it will stay down. When you press it again, it will release.

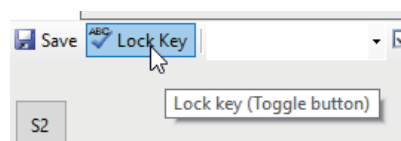

\*For combinations with S1/S3, press the buttons beginning with S1/S3.

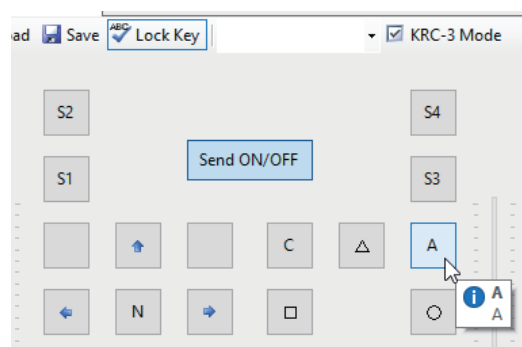

5. PA1/PA2/PA3/PA4 is the slide bar for analog control. It can be used with motions that use analog functions.

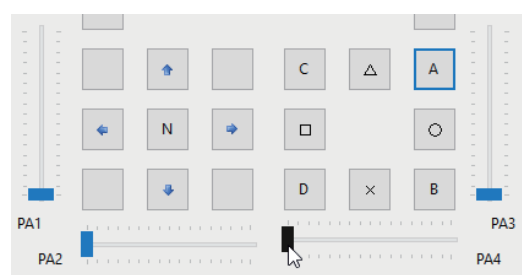

6. When you are finished, release "Send ON/OFF" and close the window.

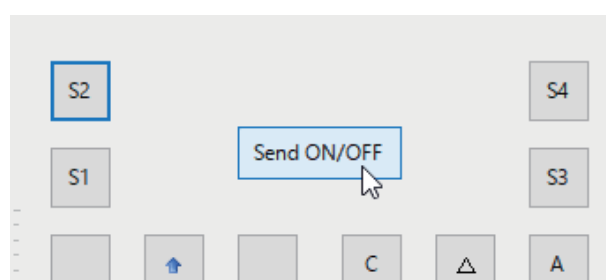

# Running Sample Motions 5

## Sample Motion List

Robot: KXR-L2G Gripper type Servo: KRS-3301 x12 KRS-3304 x6

Category	No.	Motion Name	Key number (Command value)	Symbol (KRC Commander)		
Move Motion	XL2G_101	Short-step walking	Forward	513	S1 + ↑	
	XL2G_102		Reverse	514	S1 + ↓	
	XL2G_103		Left side step	520	S1 + ←	
	XL2G_104		Right side step	516	S1 + →	
	XL2G_105	The slow-speed walking	Forward (5)	0	-	
	XL2G_106		Reverse (5)	0	-	
	XL2G_107		Left side step	0	-	
	XL2G_108		Right side step	0	-	
	XL2G_109	The high-speed walking (with Gyro)	Forward	1	↑	
	XL2G_110		Reverse	2	↓	
	XL2G_111		Left side step	8	←	
	XL2G_112		Right side step	4	→	
	XL2G_113		Turn Left	9	↑←	
	XL2G_114	Turn Right	5	↑→		
XL2G_115	Stand up	The face up	2049	S3 + ↑		
XL2G_116		The face down	2050	S3 + ↓		
XL2G_117		Automatic	0	-		
Basic Motion	XL2G_201	The Greeting		16	△	
	XL2G_202	Wave hands		592	S1 + A (△○)	
	XL2G_204	Push ups	5回	32	X	
	XL2G_203	Rejoice		96	B (○X)	
	XL2G_205	Regret	Left-foot	288	D (□X)	
	XL2G_206	Shoot	Right-foot	272	C (△□)	
			Left-foot	80	A (△○)	
	XL2G_208	Foot ball pass	Right-foot	256	□	
				64	○	
	XL2G_209	Goalkeeper		800	S1 + D (□X)	
	XL2G_211	Punch	Left hand	15	SP1 (↑↓←→)	
	XL2G_212		Right hand	368	SP2 (△□X○)	
	XL2G_213		Left side	768	S1 + □	
	XL2G_214		Right side	576	S1 + ○	
	XL2G_215	Defense		544	S1 + X	
	XL2G_216	Handstand		518	S1 + ↓→	
	XL2G_217	Forward roll		522	S1 + ↓←	
XL2G_291	Home position		0	-		
XL2G_292	Low voltage	Relax	0	-		
Transport Motion	XL2G_301	Grab →Let go		1024	S2	
	XL2G_302 XL2G_303 XL2G_304 XL2G_305 XL2G_306 XL2G_307	RC Walking while grabbing	Right Arm	Forward	1025	S2 + ↑
				Back	1026	S2 + ↓
				Left side	1032	S2 + ←
				Right side	1028	S2 + →
				Turn Left	1033	S2 + ↑←
				Turn Right	1029	S2 + ↑→
	XL2G_308	Throw away		1040	S2 + △	
	XL2G_309	Grab →Let go		4096	S4	
	XL2G_310 XL2G_311 XL2G_312 XL2G_313 XL2G_314 XL2G_315 XL2G_316	RC Walking while grabbing	Left Arm	Forward	4097	S4 + ↑
				Back	4098	S4 + ↓
				Left side	4104	S4 + ←
				Right side	4100	S4 + →
				Turn Left	4105	S4 + ↑←
				Turn Right	4101	S4 + ↑→
Throw away					4112	S4 + △

• △○ and →↓ are button combinations. With controllers like KRC-5FH, they can be run with diagonal buttons. For example, S1+△○ refers to pressing the button on the diagonal upper-right on the right side while pressing the S1 button. When using HeartToHeart4's KRC Commander, press Key Lock and at the same time press the button. The SP1 and SP2 buttons are special buttons in the middle of KRC-5FH.

- For high-speed movement, it is recommended that you mount a gyro.
- The motion that automatically determines whether the robot has gotten up should be used with an acceleration sensor.
- When grabbing objects, press S1. If you continue pressing S1, it will hold on to the object that was grabbed. When you release S1, it will put down the object at that spot. With S1 pressed, you can press ↑, etc. to move around while holding the object. Use S1 and △ together to throw the object.

### [Reduced Voltage Motion]

In the sample, when the power voltage falls under 6V, **the robot crouches down and is depowered.**  
**When this occurs, charge or replace the battery.**

\* When running a motion with a large load, like when operating all the servos simultaneously, depending on the battery's remaining charge, reduced voltage motion may be run.

**To restore the robot from the reduced voltage motion, turn the power off and on or charge the battery.**

To cancel reduced voltage motion, change the setting for "Run motion when power voltage reduced" from the project window.

# Running Sample Motions 6

## ● Reading Project

Under standard settings, projects are saved in "Projects" in the "HeartToHeart4" folder in "My Documents". If you wish to use the same project, select "File" → "Open" → "Project" in the Main Window, to specify a project. Select a file with the extension ".h4p" in the Project folder and press "Open" to expand a project.

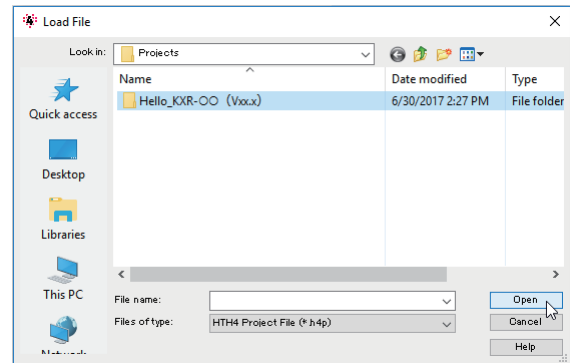
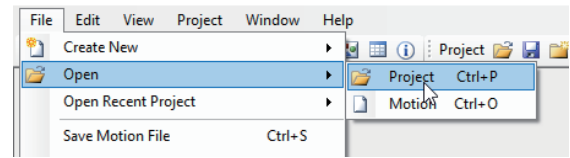

This completes the instructions for assembly and running motions. For software operation instructions, refer to the "HeartToHeart4 User's Manual".

Always check the "Reduced voltage motion setting" as shown on the next page. (With an LiFe battery set)

\* On the slippery surface, can adjust grip with option sponge.

No.01228  
Sole grip A (High grip)  
No.01229  
Sole grip B (Normal)

<For Sole>

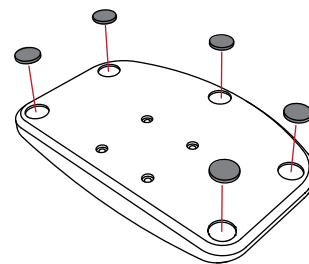

No.02336  
Grip sheet (Normal) (2 sheets)

<Ex.Cut line>

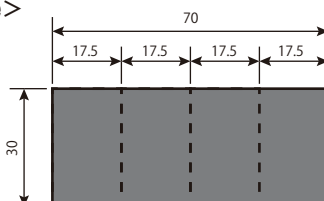

<For Arm>

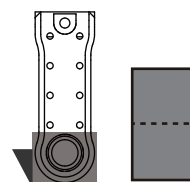

<For Joint base>

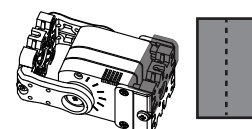

# Reduced Voltage Motion Setting for Li-Fe Batteries

## ■ Battery over discharge prevention setting <Always enable this setting before use>

If the battery capacity runs down while in use, the voltage will decrease, but when a rated 9.9V LiFe battery that has dropped below 9.0V, or a 6.6V LiFe battery, below 6.0V, is used, it will damage the battery and the battery itself will expand. This is called over discharge. If you continue to use the battery in this state, it will cause smoke or fire.

In order to prevent this, there is a function that automatically runs a motion when the battery drops below the specified voltage. Using this function, you can enable a setting to prevent the LiFe battery from over discharge.

**\*In the included sample project, the setting has already been enabled as below, but be aware that you will need to re-enable the over discharge prevention setting every time you create a new project.**

### 1. Set the project and open the project window.

Set the motion to run when power voltage drops below the voltage that you indicate.



### 2. Set the voltage for running the reduced voltage motion to 6.0V.

The voltage per cell cannot drop below 3.0V, so 3.0V x 2 cells is 6.0V.

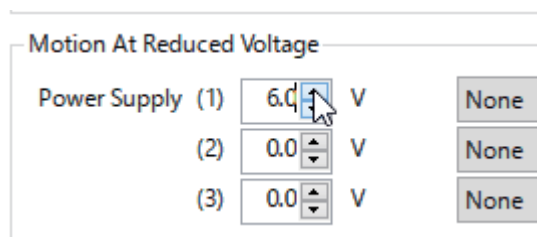

### 3. Select the motion to automatically run when the battery drops below the set voltage.

Select low voltage indicator motion.

If you run an active motion at low voltage, it will consume more of the battery and could lead to over discharge.

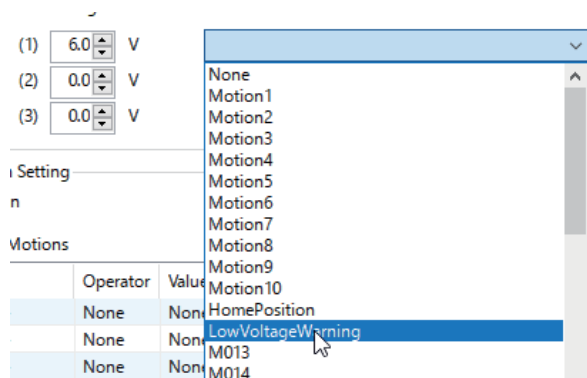

### 4. Click "Save all in ROM" and load into RCB-4. The process is complete when the robot restarts.

When ending the process, always save the project first before closing HeartToHeart4.

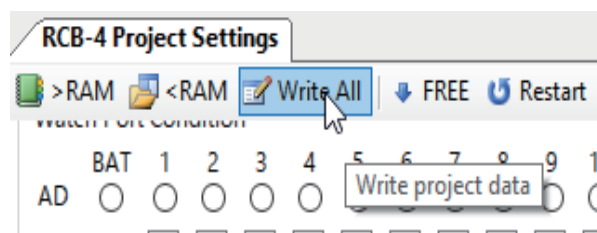

When you've completed these settings, the specified motion will automatically run when the battery's voltage falls below 6.0V. If the specified motion is run when you are operating the robot, promptly recharge the battery or replace it with a charged battery.

# Option Parts List 1

KXR Option Parts List			
Part No.	Part Name	Contents	Price
<b>KXR Frame Parts</b>			
02300	Joint base A (10 sets)	Joint base and joint nut set.	¥ 800
02301	Joint nut A (20 sets)	For joint nut replacement.	¥ 600
02302	Servo arm 3300A (38mm) (2 sets)	Arm and joint set.	¥ 600
02303	Servo arm 3300A (26mm) (2 sets)	Arm and joint set.	¥ 600
02304	Servo arm 3300A (20mm) (2 sets)	Arm and joint set.	¥ 600
02305	Joint frame A+B セット (Each 4 sets)	Set of two types of frames for securing servos and joints.	¥ 600
02306	Arm supporter 3300A (4 pcs)	Supporter for securing servos in the front-back direction.	¥ 400
02307	Cross frame 3300 セット	Perpendicular shaft frame and joint set.	¥ 1,000
02308	Angle bracket 3300 (2 sets)	Bracket for securing a servo and arm at a 90-degree angle.	¥ 400
02309	Dummy servo 3300 (2 pcs)	Dummy servo for servo replacement.	¥ 600
02310	Sole S-03 (2 pcs)	Sole grips (sold separately) can be attached to the underside.	¥ 800
02311	Body plate set A (Each 2 pcs)	Set of panels for securing servos and making the body.	¥ 800
02312	Backpack set (KXR)	Backpack for installing electronic components, etc.	¥ 1,500
02313	Battery box (KXR)	Box for storing the battery and making the body.	¥ 1,200
02314	Cable guide X (10 pcs)	Part for wiring cable along the arm.	¥ 300
02315	Arm supporter 3300B (4 sets)	Supporter for securing the side of a servo, etc. via a cantilever.	¥ 400
02316	Bottom spacer 3300A (4 sets)	Spacer for securing the bottom side of a servo to a panel, etc.	¥ 400
02317	Sensor base A (2 pcs)	Base part for installing an infrared sensor, etc.	¥ 300
02318	Gripper hand set	Set of parts for a gripper that opens and closes with a servo.	¥ 800
02319	Flat frame 3300 (4 sets)	Frame that can connect servos together in five different lengths.	¥ 400
02320	Servo wheel (φ60) (2 sets)	A servo can be used as an in-wheel motor.	¥ 600
02321	Parts bag A Body parts set	Full set of parts for making the robot's body.	¥ 3,500
02322	Parts bag B Arm set (Each 4 sets)	Set of three types of arms and joints, and cable guides.	¥ 3,500
02323	Parts bag C Joint set (Assort set)	Set of joint-system frame parts.	¥ 3,200
<b>Screw / Nut</b>			
02324	M2.6-10BH screw (100 pcs)	Screws mainly for securing arms and frames to joints.	¥ 500
02086	M2-4 Low head screw (100 pcs)	Used to secure joints and horns, etc.	¥ 500
02325	M2-6 Low head screw (100 pcs)	Used to secure frame parts to a servo, etc.	¥ 400
02326	M2-8 Low head screw (100 pcs)	Used to secure joints together and to body panels, etc.	¥ 400
02327	M2-12 Low head screw (100 pcs)	Secures body panels and servos through joints.	¥ 400
02176	M3-6 Low head horn screw (50 pcs)	Screw for KRS-3300 series standard upper shaft.	¥ 500
02083	M3-8 Low head horn screw (50 pcs)	Used to fasten together joints, wheels, etc.	¥ 500
02164	2.6-4 Flat head screw (100 pcs)	Used to secure arms and electronic components to bottom shafts, etc.	¥ 600
02088	M2 Nut (50 pcs)	Can be used instead of the plastic nut's M2 part.	¥ 300
02337	M2.6 Nut (50 pcs)	Can be used instead of the plastic nut's M2.6 part.	¥ 300
02328	Screw set A (KXR) (Assort set)	Full set of screws for KXR in a dedicated case.	¥ 1,800
02333	KONDO Screw case	Compact screw case with movable partitions.	¥ 300
<b>ZH Connection Cable</b>			
02329	ZH Connection Cable 2 Type A (60mm)	For connecting servos and boards, and servos and servos.	¥ 400
02330	ZH Connection Cable 2 Type A (120mm)	For connecting servos and boards, and servos and servos.	¥ 400
02331	ZH Connection Cable 2 Type A (160mm)	For connecting servos and boards, and servos and servos.	¥ 400
02332	ZH Connection Cable 2 Type A (200mm)	For connecting servos and boards, and servos and servos.	¥ 400

Please check KONDO web site for more information.

# Option Parts List 2

KXR Option Parts List			
Part No.	Part Name	Contents	Price
<b>Servo Motor</b>			
03115	KRS-3301 ICS	Standard servo for KXR.	Open
02181	Plastic gear set [KRS-3301]	For KRS-3301.	¥ 300
02182	Servo case [KRS-3301]	For KRS-3301.	¥ 600
03103	KRS-3304 ICS	Upgrade servo. Same size as 3301.	Open
02141	Servo gear set [KRS-3304]	For KRS-3304.	¥ 3,500
02142	Servo case [KRS-3300 series]	For KRS-3304.	¥ 600
02183	Case screw set [KRS-3300 series] (20pcs)	For KRS-3300 series.	¥ 400
<b>Control Board, Cable</b>			
03120	RCB-4 mini	Standard control board for KXR.	¥ 9,800
02146	Connection Cable (1.5m)	Connect to Robot from PC.	¥ 800
02177	ZH Conversion cable (100mm)	Connect to RCB-4mini from Dual USB Adapter HS.	¥ 400
02166	LV Power switch Harness	For LV Battery use.	¥ 800
02116	Dual USB Adapter HS	For USB connection to PC.	¥ 6,000
<b>Grip Sponge</b>			
01228	Sole grip A (High grip)	For Sole. Soft type.	¥ 300
01229	Sole grip B (Normal)	For Sole. Hard type.	¥ 300
02336	Grip sheet 70x30mm (Normal) (2 sheets)	Multiuse free cut. Hard type.	¥ 600
<b>Wireless Unit</b> ※The KRC-5FH wireless controller is only certified in Japan.			
03099	KRC-5FH Tx / Rx set	2.4Ghz wireless controller and receiver set.	¥ 14,500
03106	KRR-5FH Rx	Add on receiver.	¥ 7,500
03062	Bluetooth module KBT-1	Bluetooth connect to PC / Android device.	¥ 12,000
<b>Sensor</b>			
03124	KRG-4 B set (ZH⇔ZH) 2 sets	Gyro sensor for stability.	¥ 9,000
03123	RAS-3 B set (ZH⇔ZH)	Accelerometer for judge lie down facing up or down.	¥ 3,800
02125	PSD sensor B set (ZH⇔ZH)	Infrared distance sensor.	¥ 2,200
<b>Battery, Charger</b>			
02335	ROBO Power cell E type 6N-800 (Ni-MH)	Nickel-metal hydride rechargeable battery.	¥ 3,500
51204	USB charger BX-32MH (Ni-MH only)	For USB charging adapter (5V2A)	¥ 2,800
02167	ROBO Power cell F2-850 type (Li-Fe)	Lithium ferrite rechargeable battery.	¥ 2,700
51203	USB charger BX-31LF (Li-Fe only)	For USB charging adapter (5V2A)	¥ 2,800
<b>Decal, Driver</b>			
02334	Decal (KXR)	Standard decal.	¥ 500
04045	Cushion grip driver 610 + #0 x 100	Easy to turn with rubber grip. Magnet tip.	¥ 450
04046	Cushion grip driver 610 + #1 x 100	Easy to turn with rubber grip. Magnet tip.	¥ 450
04047	Cushion grip driver 610 + #0 x 75	Easy to turn with rubber grip. Magnet tip.	¥ 450
04048	Cushion grip driver 610 + #1 x 75	Easy to turn with rubber grip. Magnet tip.	¥ 450

Please check KONDO web site for more information.



# Method for Mounting on Backpack

## Method for Mounting on Backpack

\*Please refer each manuals.

**KRR-5FH : Receiver for wireless controller**  
Enables wireless operations with KRC-5FH.

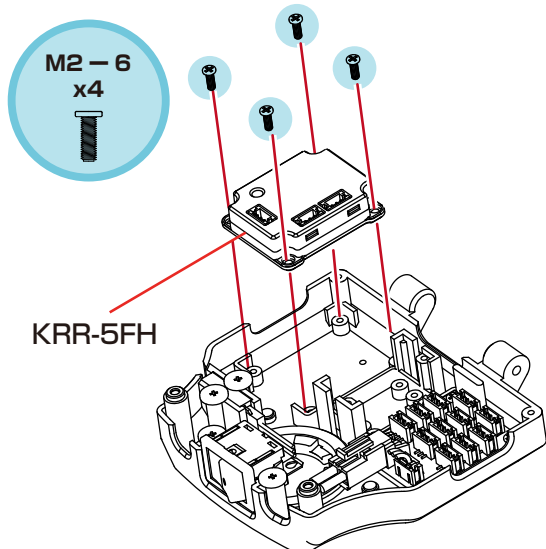

**Example :**

Connect KRR-5FH to the RCB-4mini's SIO port.  
\*The sample motion uses the port in the diagram.  
If a servo is connected, remove it and connect it to the KRR-5FH port.  
It does not matter which of KRR-5FH's SIO ports is used; it has no impact on operations. Also, daisy chain connection is possible just as with servos.

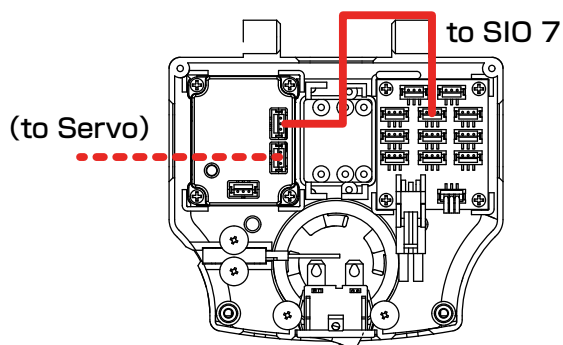

**KRG-4 : Gyro sensor**  
Robot movements are stabilized by correcting postural changes.

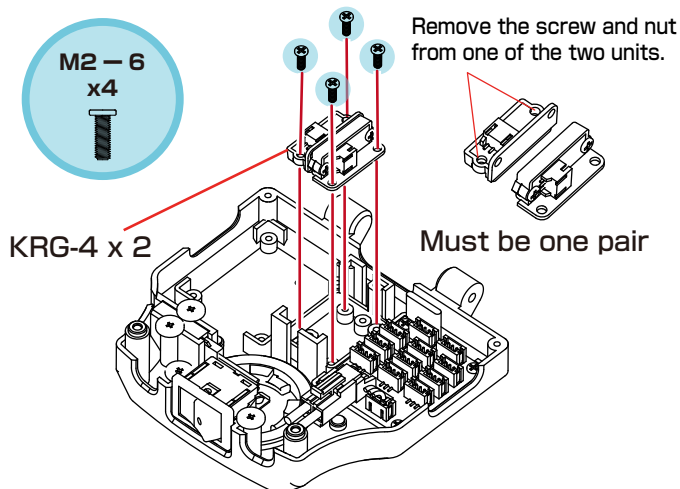

**Example :**

Connect KRG-4 and the RCB-4mini AD port.  
\*The sample motion uses the port in the diagram.

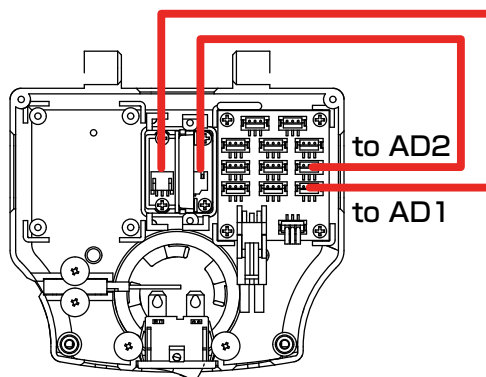

**RAS-3 : 3 Axis Accelerometer**  
Used to determine the robot's posture by detecting the tilt of its body.

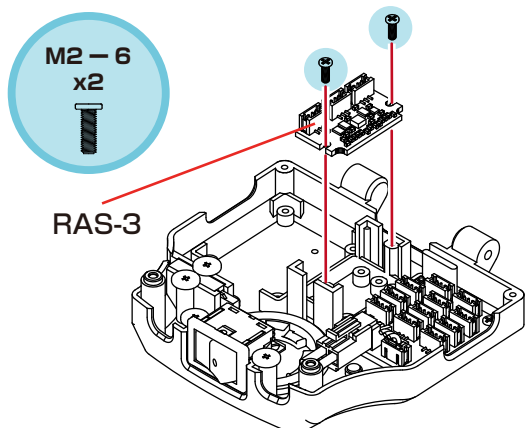

**Example :**

Connect the RAS-3 and RCB-4 mini's AD port.  
\*The sample motion uses the port in the diagram.  
Front-back determined with AD4 (Z axis). (KXR-L2)

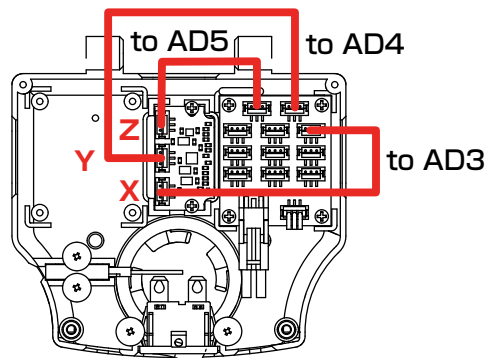

# Reference Parameter for Gyro Sensor

## ■KXR-L2

<Recommended settings>

▼SIO 2.	Port(Gyro)	MIX 1
ID7:Right Ankle(Pitch)	AD2	+9
ID8:Right Ankle(Roll)	AD1	+8

▼SIO 6.	Port(Gyro)	MIX 1
ID7:Left Ankle(Pitch)	AD2	+9
ID8:Left Ankle(Roll)	AD1	+8

<Ex:Setting Window of HTH4>

The screenshot shows the 'RCB-4 Project Settings' window. It includes sections for 'Analog Reference Value Settings' and 'Mixing Settings'.

**Analog Reference Value Settings:** Shows settings for AD channels (BAT, 1-10) with Real, Ref., and Diff. values.

**Mixing Settings:** Displays two tables for SIO1,2,3,4 and SIO5,6,7,8. Each table lists Name, ID, MIX1 Src, MIX1 Ratio, MIX2 Src, and MIX2 Ratio.

Name	ID	MIX1 Src	MIX1 Ratio	MIX2 Src	MIX2 Ratio
右肘	3	OFF	1	OFF	1
右腿 (ロール)	4	OFF	1	OFF	1
右腿 (ピッチ)	5	OFF	1	OFF	1
右膝	6	OFF	1	OFF	1
右足首 (ピッチ)	7	AD2	9	OFF	1
右足首 (ロール)	8	AD1	8	OFF	1
右拡張2	9	OFF	1	OFF	1
右拡張3	10	OFF	1	OFF	1
右拡張4	11	OFF	1	OFF	1

  

Name	ID	MIX1 Src	MIX1 Ratio	MIX2 Src	MIX2 Ratio
左肘	3	OFF	1	OFF	1
左腿 (ロール)	4	OFF	1	OFF	1
左腿 (ピッチ)	5	OFF	1	OFF	1
左膝	6	OFF	1	OFF	1
左足首 (ピッチ)	7	AD2	9	OFF	1
左足首 (ロール)	8	AD1	8	OFF	1
左拡張2	9	OFF	1	OFF	1

# Method for Mounting Sensor Base

## ■ Method for Mounting Sensor Base

① Attach the sensor base to the joint base.

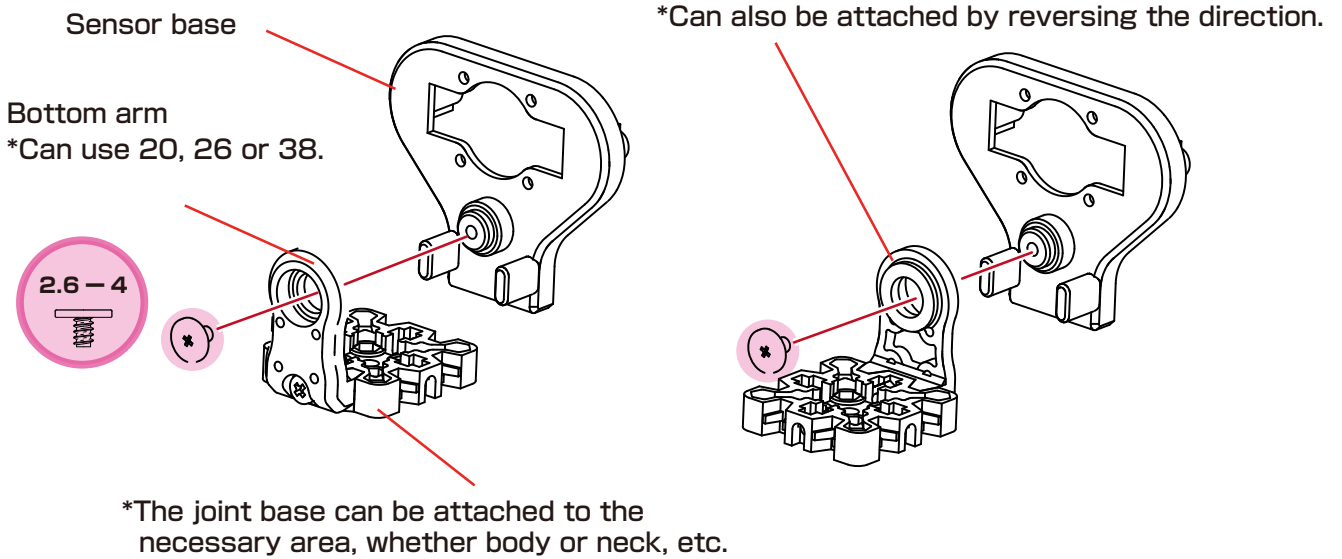

②-1. PSD Sensor

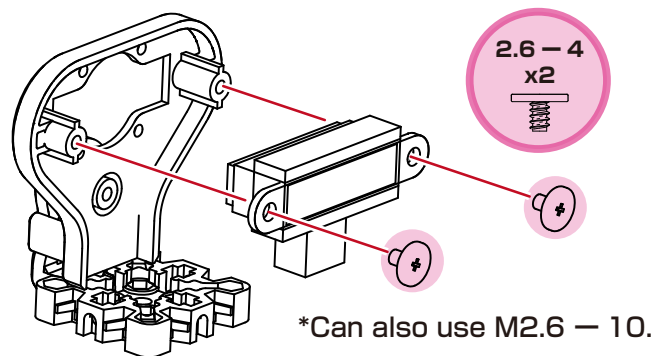

②-2. USRX-1

